

CB-2710 CB-2720

平型片面飾り・両面飾り縫ミシン

SOTTOM COVERING STITCHER WITH FLAT BED

TOP & BOTTOM COVERING STITCHER WITH FLAT BED

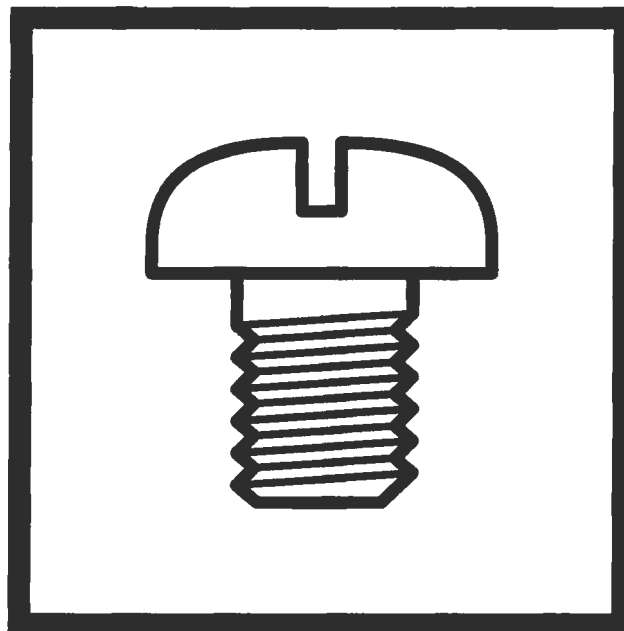

brother[®]

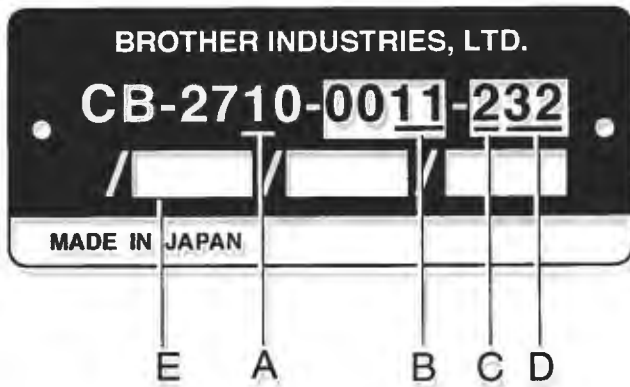

A	機種記号 / Model
1	片面飾り Bottom covering stitcher
2	両面飾り Top and bottom covering stitcher

C	D	針数 No. of needles	針幅 Needle gauge
2	32	二本針 2 needles	3.2mm
2	40	二本針 2 needles	4.0mm
2	48	二本針 2 needles	4.8mm
2	56	二本針 2 needles	5.6mm
2	64	二本針 2 needles	6.4mm
3	48	三本針 3 needles	4.8mm
3	56	三本針 3 needles	5.6mm
3	64	三本針 3 needles	6.4mm

B	仕様 / Specifications
11	地縫用 Plain stitching
21	テープ付け用 Tape attaching
31	カバーリング用 Covering
71	レースゴム付用 (上ゴム送り・右メス装置付) Elastic lace attaching with top metering right knife
75	415V レースゴム付用 (パルスモータ式上ゴム送り装置PM1・右メス装置付) Elastic lace attaching with top metering with pulse motor right knife
7A	100V レースゴム付用 (パルスモータ式上ゴム送り装置PM1・右メス装置付) Elastic lace attaching with top metering with pulse motor right knife
7B	110V レースゴム付用 (パルスモータ式上ゴム送り装置PM1・右メス装置付) Elastic lace attaching with top metering with pulse motor right knife
7D	200V レースゴム付用 (パルスモータ式上ゴム送り装置PM1・右メス装置付) Elastic lace attaching with top metering with pulse motor right knife
7E	220V レースゴム付用 (パルスモータ式上ゴム送り装置PM1・右メス装置付) Elastic lace attaching with top metering with pulse motor right knife
7F	230V レースゴム付用 (パルスモータ式上ゴム送り装置PM1・右メス装置付) Elastic lace attaching with top metering with pulse motor right knife
7G	240V レースゴム付用 (パルスモータ式上ゴム送り装置PM1・右メス装置付) Elastic lace attaching with top metering with pulse motor right knife
7H	380V レースゴム付用 (パルスモータ式上ゴム送り装置PM1・右メス装置付) Elastic lace attaching with top metering with pulse motor right knife
T1	ベルトループ縫用 (薄物・中厚物用) Belt loop sewing Light・Medium
T2	ベルトループ縫用 (厚物用) Belt loop sewing Heavy
U1	ベルトループ縫用・前メス装置付 (薄物・中厚物用) Belt loop sewing Light・Medium (With front cutter)
U2	ベルトループ縫用・前メス装置付 (厚物用) Belt loop sewing Heavy (With front cutter)

E	装置 / Device
ATC1	自動定寸テープカッター装置 電磁式 Automatic tape cutter Solenoid type
TC1	テープカッター装置エア式 (ヒサスイッチ付) Tape cutter Knee SW. Pneumatic type
TC3	テープカッター装置電磁式 (ヒサスイッチ付) Tape cutter Knee SW. Solenoid type
TFH	自動テープ送り出し装置横送りテーブル取付 Automatic tape feeder Horizontal type
TFV	自動テープ送り出し装置縦送りテーブル取付 Automatic tape feeder Vertical type
CH1	チェーンカッター装置<水平式>エア式 Horizontal chain cutter Pneumatic type
CH2	チェーンカッター装置<水平式>バキューム式 Horizontal chain cutter Vacuum type
PM1	パルスモータ式上ゴム送り装置 Top metering device driven by pulse motor

パーツブックご利用に際して

1. この本は、この本の表紙（正誤表の挿入されている場合は正誤表）に記載されているものと同じプレートが取り付けられているミシンのためのものです
2. 標準以外で使用する部品は

CB2710-0011
CB2720-0011

 と示します。これは、機種、サブクラスを表しています。又、両機種共通の時は0011とし、サブクラスだけを表しています。
3. 組単位で補給する部品は、

--

 破線で示しております。
4. この本は1990年11月のデータに基づいて作成されたものです。
5. 部品は予告なしに設計変更される場合があります
6. 部品コード・RMKS欄が*となっている場合は、ゲージ部品一覧表（83ページ）でお調べ下さい。

目 次

A. 主体関係	2
B. 上軸・針杆関係	10
C. 押エ関係	14
D. 針冷却装置	18
E. 送り関係	20
F. 下軸関係	24
G. 給油潤滑関係	26
H. ルーパ関係	30
J. スプレダー関係 (CB2720)	32
K1. 糸調子関係 (CB2710)	34
K2. 糸調子関係 (CB2720)	38
L. 上ゴム送り関係 (CB2710、CB2720-0071)	42
M. トリミングメス関係 (CB2710、CB2720-0071、0071)	
(□は1を除く)	46
N. ベルトループメス関係 (CB2710-00U1、00U2)	48
P1. ハルスモータ式上ゴム送り関係 (センサー)	
(CB2710、2720-007□) (□は1を除く)	52
P2. ハルスモータ式上ゴム送り関係 (上ゴム送り)	
(CB2710、2720-007□) (□は1を除く)	54
P3. ハルスモータ式上ゴム送り関係 (コントロールボックス)	
(CB2710、2720-007□) (□は1を除く)	56
P4. ハルスモータ式上ゴム送り関係 (オプション)	60
Z1. 付属品関係	62
Z2. 付属品関係 (オプション)	70
索引	71
オプション	82
ゲージ部品一覧表	83
ゲージ部品一覧表 (オプション)	92

Notes for using this parts book

1. This book is applicable to sewing machines which have the same plate number as shown on the cover of this book (or correction sheet).
2. Parts used in addition to standard parts are indicated as

CB2710 0011 CB2720 0011

 for the model and the subclass. For parts used for both models, only the subclass "0011" will be displayed.
3. Parts supplied as complete assemblies are circled by a dotted line .
4. This book was prepared based on information available in November 1990.
5. Parts are subject to changes in design without prior notice.
6. Check the gauge parts list (page 83) if there is an asterisk * in the parts code or remarks column.

CONTENTS

A . Machine body	2
B . Upper shaft and needle bar mechanism	10
C . Presser foot mechanism	14
D . Needle cooler	18
E . Feed mechanism	20
F . Lower shaft mechanism	24
G . Lubrication	26
H . Looper mechanism	30
J . Spreader mechanism (CB2720)	32
K1 . Thread tension (CB2710)	34
K2 . Thread tension (CB2720)	38
L . Upper rubber feed mechanism (CB2710, 2720-0071)	42
M . Trimming knife mechanism (CB2710, 2720-0071, 007□ - except 1)	46
N . Belt loop knife mechanism (CB2710-00U1, 00U2)	48
P1 . Pulse motor drive top metering mechanism (For sensor) (CB2710, 2720-007□ - except 1)	52
P2 . Pulse motor drive top metering mechanism (For upper rubber feed) (CB2710, 2720-007□ - except 1)	54
P3 . Pulse motor drive top metering mechanism (For control box) (CB2710, 2720-007□ - except 1)	56
P4 . Pulse motor drive top metering mechanism (Option)	60
Z1 . Accessories	62
Z2 . Accessories (Option)	70
INDEX	71
OPTION PARTS	82
GAUGE PARTS LIST	83
GAUGE PARTS LIST (OPTION)	92

A. 主体関係 / Machine body

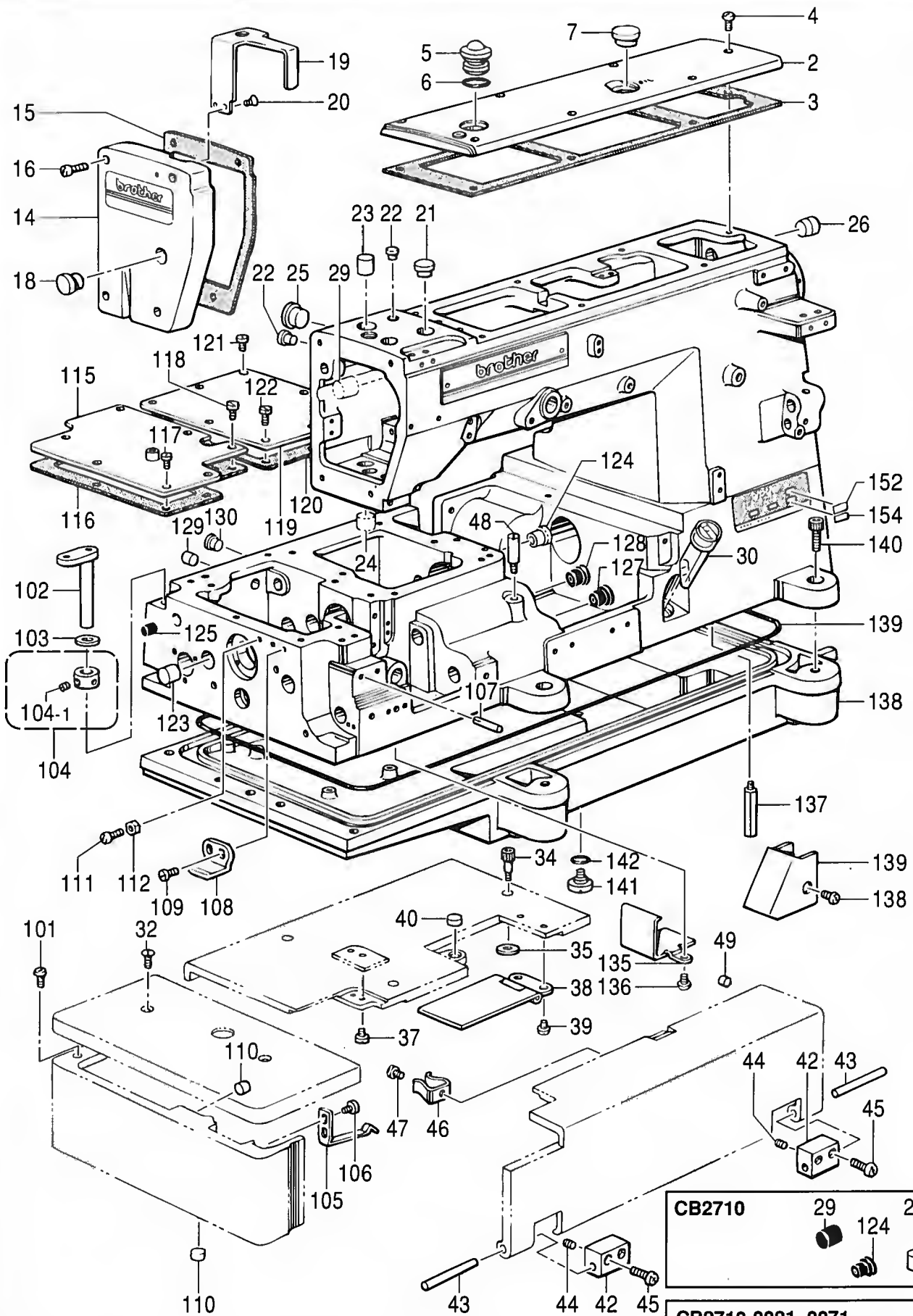

CB2710

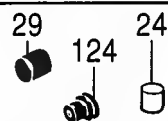

CB2710-0021, 0071
0070 (口は1を除く)
/ 0070-except 1

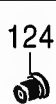

A. 主体関係 / Machine body

REF NO	CODE	Q'TY	ヒンメイ	NAME OF PARTS	RMKS
2	S08627001	1	ウフフタ	TOP COVER	
3	S08628000	1	ウフフタパツキン	TOP COVER PACKING	
4	062681012	7	ナヘ"コ437-40X10	SCREW 437X10	
5	S02606000	1	ユリヨウケイマト"	OIL GAUGE WINDOW	
6	081014670	1	Oリング"PW14	O RING PW14	
7	159150009	1	カマシ"クメクラセン	OIL CAP	
14	S08630201	1	メンイタ	FACE PLATE	
15	S08631000	1	メンイタパツキン	FACE PLATE PACKING	
16	062681612	4	ナヘ"コ437-40X16	SCREW 437X16	
18	117934009	1	メクラセン	OIL CAP	
19	S08632009	1	ハリホ"ウテンヒ"ンカハ"ー	NEEDLE THREAD TAKE-UP COVER	
20	102843004	2	サラネシ"3.57	SCREW 3.57	
21	104449009	1	メクラセン	OIL CAP	
22	104450109	2	メクラセン	OIL CAP	
23	154841009	1	メクラセン	OIL CAP	
24	154841009	1	メクラセン (B271)	OIL CAP (FOR B271)	
25	108520009	1	メクラセン	OIL CAP	
26	S00313009	1	メクラセン	OIL CAP	
27	S08633101	1	シタイトカハ"ー	BOBBIN THREAD COVER	
28	062680812	1	ナヘ"コ437-40X8	SCREW 437X8	
29	156887001	1	メクラセン17 (B271)	OIL CAP (17)(FOR B271)	
30	148084001	1	オイルゲ"ー"シ"マト"	OIL GAUGE WINDOW	
32	100032004	2	サラネシ"4.37	SCREW 4.37	
34	S09123101	3	アナホ"ルト4.37X15	BOLT 4.37X15	
35	S08639000	1	クロスプレートパツキン	CLOTH PLATE PACKING	
37	123185001	2	マルヒラネシ"3.57X4.5	SCREW 3.57X4.5	
38	S08642001	1	シタイトテンヒ"ンカハ"ー"クミ	LOOPER THREAD TAKE-UP COVER ASSEMBLY	
39	123185001	2	マルヒラネシ"3.57X4.5	SCREW 3.57X4.5	
40	S08646100	1	マグ"ネット	MAGNET	
42	S08651001	2	マエカハ"ー"ササエ	FRONT COVER SUPPORT	
43	S08652000	2	マエカハ"ー"ササエシ"ク	FRONT COVER SUPPORT SHAFT	
44	153675001	2	アナムネシ"4.37	SET SCREW 4.37	
45	060681612	4	ハ"イント"437-40X16	SCREW 437X16	
46	114985001	1	ハ"ットカハ"ー"トメハ"ネ	BED COVER SET SPRING	
47	062680612	1	ナヘ"コ437-40X6	SCREW 437X6	
48	S08653001	1	ハ"ネウケネシ"	SCREW	
49	142274009	2	メクラセン	OIL CAP	
101	062680812	2	ナヘ"コ437-40X8	SCREW 437X8	
102	S00017001	1	クロスプレートササエシ"ク	CLOTH PLATE SUPPORT SHAFT	
103	141183000	1	クロスプレートシート	CLOTH PLATE SEAT	
104	181969003	1	セツカラー"クミ	SET COLLAR ASSEMBLY	
104-1	101706001	2	トメネシ"6.35	SET SCREW 6.35	
105	S08667001	1	ヨコカハ"ー"トメイタハ"ネ	SIDE COVER STOP SPRING	
106	060680712	2	ハ"イント"437-40X7	SCREW 437X7	
107	140063001	1	ミゾ"ツキピン	DOWEL PIN	
108	S08668001	1	ヨコカハ"ー"ガイ"ト"	SIDE COVER GUIDE	
109	107407003	2	シメネシ"4.37	SCREW 4.37	
110	146586009	2	メクラセン	OIL CAP	
111	062681012	1	ナヘ"コ437-40X10	SCREW 437X10	
112	105234003	1	ナツ"ト4.37	NUT 4.37	
115	S08669001	1	オクリキコウカハ"ー	FEED MECHANISM COVER	
116	S08670000	1	オクリキコウカハ"ー"パツキン	FEED MECHANISM COVER PACKING	
117	107407003	6	シメネシ"4.37	SCREW 4.37	
118	117516001	1	ボ"ルト4.37	BOLT 4.37	
119	S08671101	1	ハ"ット"ウフカハ"ー	BED UPPER COVER	
120	S08672000	1	ハ"ット"ウフカハ"ー"パツキン	BED UPPER COVER PACKING	
121	107407003	4	シメネシ"4.37	SCREW 4.37	
122	117516001	2	ボ"ルト4.37	BOLT 4.37	
123	S00313009	1	メクラセン	OIL CAP	
< FOR CB2710 >					
< FOR CB2720-0021, 0071, 007 (□は1を除く) / 007□ - except 1 >					
124	S08673000	1	メクラセン	OIL CAP	

A. 主体関係 / Machine body

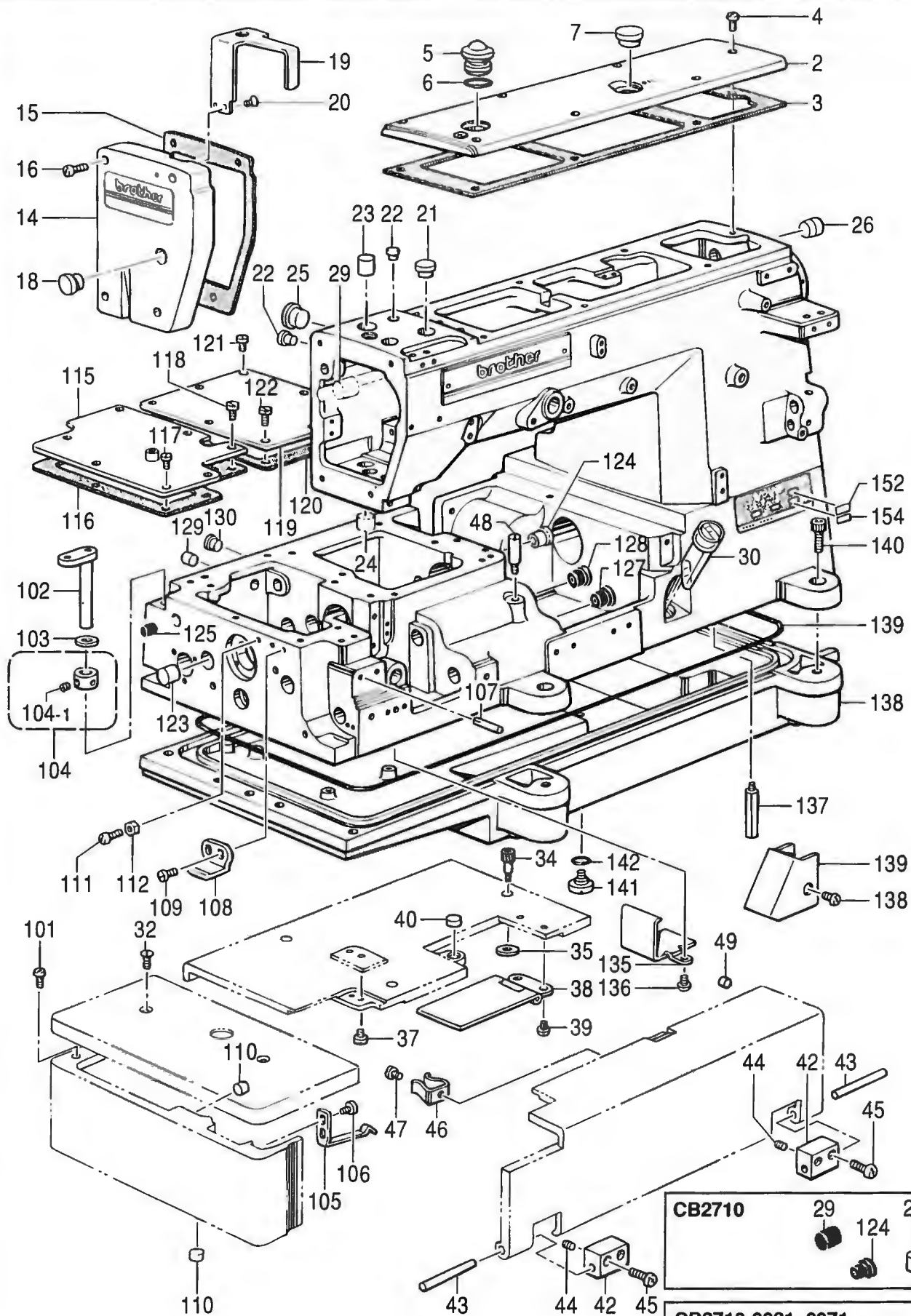

CB2710	29	124	24
CB2710-0021, 0071			
0070 (口は1を除く)			
/ 0070-except 1		124	

A. 主体関係/Machine body

REF NO	CODE	Q'TY	ヒンメイ	NAME OF PARTS	RMKS
125	146315000	1	メクラセン	OIL CAP	
127	S08673000	1	メクラセン	OIL CAP	
128	S08673000	1	メクラセン	OIL CAP	
129	146586009	1	メクラセン	OIL CAP	
130	104450109	1	メクラセン	OIL CAP	
135	146457001	1	シキリイタ	OIL STOPPER PLATE	
136	062670612	2	ナヘ"ユ357-40X6	SCREW 357X6	
137	151059001	4	ホンタイシチユウ	MACHINE BODY LEG	
138	S08674000	1	アフ"ラウケ	OIL RESERVOIR	
139	S08675000	1	Oリング"	O RING	
140	018081622	5	アナホ"ルト8X16	BOLT 8X16	
141	110641002	1	タ"ンネシ"9.52	STUD SCREW 9.52	
142	109203001	1	Oリング"	O RING	
152	*	1	シヨウラヘル	LABEL	
< FOR CB2710, CB2720-007 (は1を除く) / 007 - except 1 >					
154	S19855026	1	ソウチヒヨウシ"ラヘルPM1	LABEL (PM1)	

A. 主体関係 / Machine body

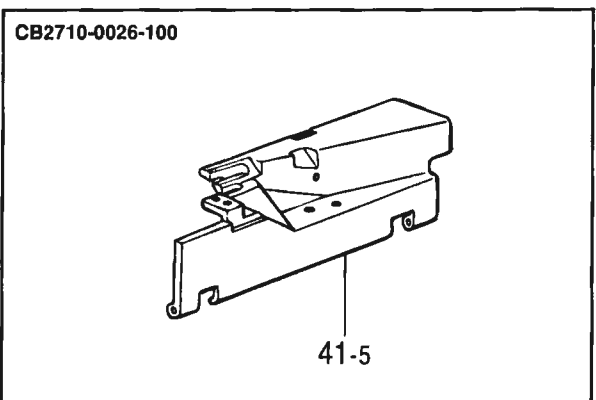
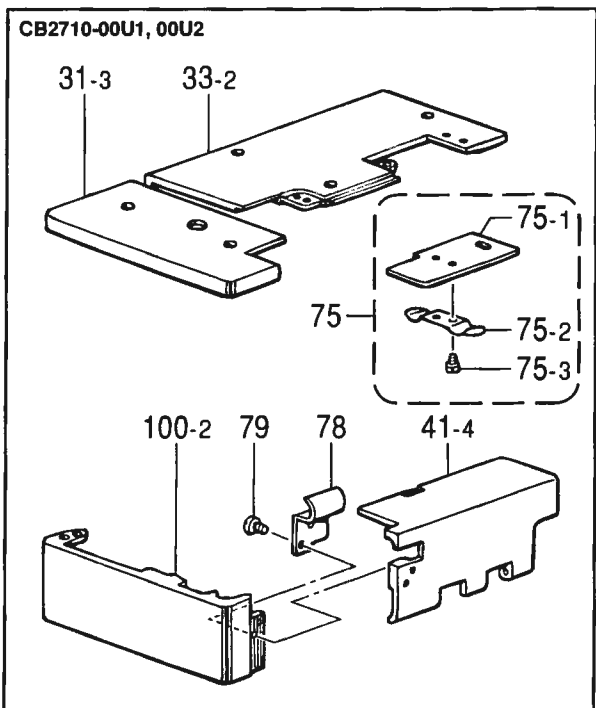
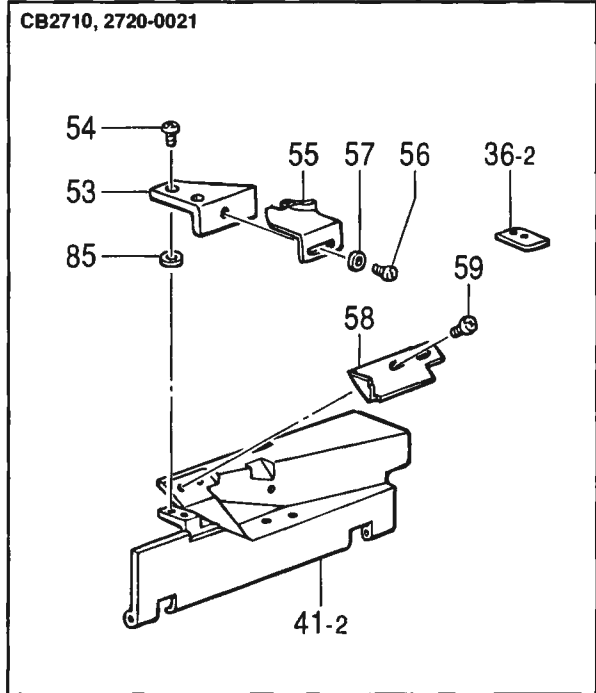
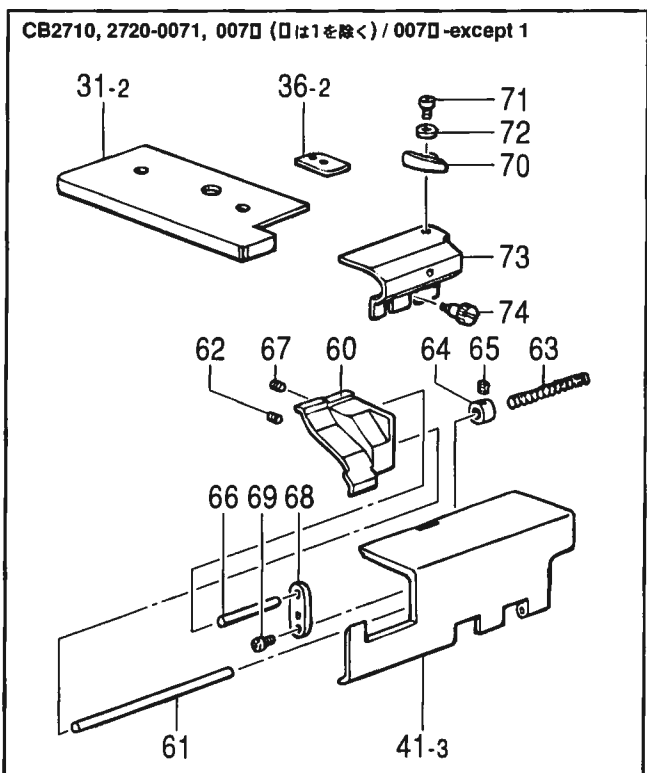
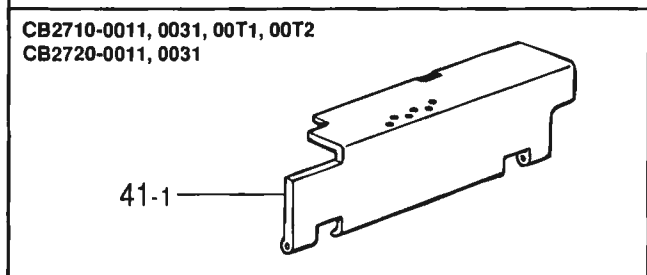
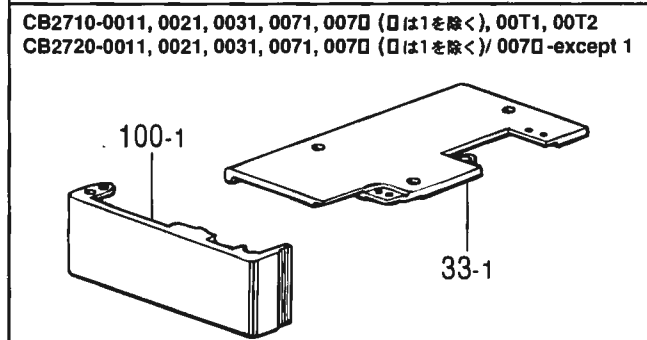
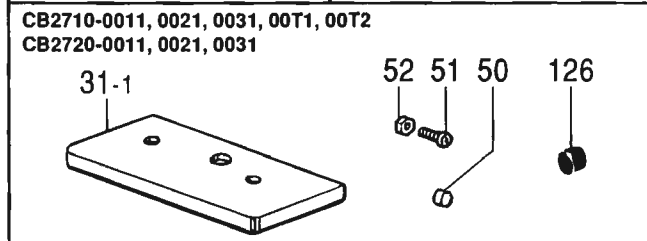
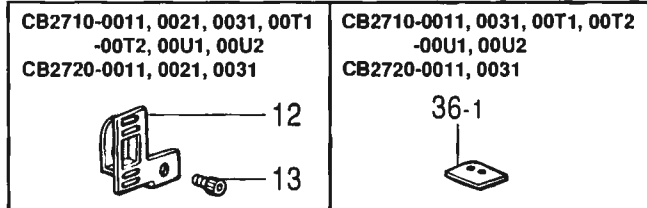

A. 主体関係 / Machine body

REF NO.	CODE	Q'TY	ヒンメイ	NAME OF PARTS	RMKS
< FOR CB2710-0011, 0021, 0031, 00T1, 00T2, 00U1, 00U2 >					
< FOR CB2720-0011, 0021, 0031 >					
12	S08629009	1	ハライトクリカハ-	NEEDLE THREAD TAKE-UP COVER	
13	018060822	1	アナホ"ルト6X8	BOLT 6X8	
< FOR CB2710-0011, 0021, 0031, 00T1, 00T2 >					
< FOR CB2720-0011, 0021, 0031 >					
31-1	S08634101	1	クロスプレートL	CLOTH PLATE (L)	
50	146586009	1	メクラセン	OIL CAP	
51	062681412	1	ナヘ"コ437-40X14	SCREW 437X14	
52	105234003	1	ナツト4.37	NUT 4.37	
126	140065001	1	メクラセン	OIL CAP	
< FOR CB2710-0011, 0021, 0031, 0071, 007□ (□は1を除く), 00T1, 00T2 / 007□ - except 1 >					
< FOR CB2720-0011, 0021, 0031, 0071, 007□ (□は1を除く) / 007□ - except 1 >					
33-1	S08637001	1	クロスプレートR	CLOTH PLATE (R)	
100-1	S08665001	1	ヨコカハ-	SIDE COVER	
< FOR CB2710-0011, 0031, 00T1, 00T2, 00U1, 00U2 >					
< FOR CB2720-0011, 0031 >					
36-1	S08640001	1	クロスプレートホジ"ヨイタ	SUB-CLOTH PLATE	
< FOR CB2710-0011, 0031, 00T1, 00T2 >					
< FOR CB2720-0011, 0031 >					
41-1	S08647001	1	マエカハ-	FRONT COVER	
< FOR CB2710, 2720-0021, 0071, 007□ (□は1を除く) / 007□ - except 1 >					
36-2	S08641001	1	クロスプレートホジ"ヨイタ	SUB-CLOTH PLATE	
< FOR CB2710, CB2720-0021 >					
41-2	S08648001	1	マエカハ-	FRONT COVER	
53	S08654001	1	マエカハ-"ホジ"ヨイタ	SUB-FRONT COVER	
54	062710812	2	ナヘ"コ476-32X8	SCREW 476X8	
55	S08655001	1	アテシ"ヨウキ"	PATCH RULER	
56	062710612	1	ナヘ"コ476-32X6	SCREW 476X6	
57	148847001	1	サ"カ"ネ	WASHER	
58	S08656001	1	コロモヨケ	FABRIC GUARD	
59	060680512	2	ハ"イント"437-40X5	SCREW 437X5	
85	025710232	2	ヒラサ"カ"ネチユウ4.76	PLAIN WASHER 4.76	
< FOR CB2710, CB2720-0071, 007□ (□は1を除く) / 007□ - except 1 >					
31-2	S08635101	1	クロスプレートL	CLOTH PLATE (L)	
41-3	S08649001	1	マエカハ-	FRONT COVER	
60	S08657001	1	スライド"カハ-	SLIDE COVER	
61	S08658001	1	スライド"ジ"ク	SLIDE COVER SHAFT	
62	014680422	2	アナトメネシ"4.37クホ"ミ	SET SCREW 4.37	
63	S08659001	1	スライド"ハ"ネ	SLIDE COVER SPRING	
64	120068001	1	セツトカラー	SET COLLAR	
65	014680422	1	アナトメネシ"4.37クホ"ミ	SET SCREW 4.37	
66	S09396001	1	カ"イト"ジ"ク	GUIDE SHAFT	
67	014680422	1	アナトメネシ"4.37クホ"ミ	SET SCREW 4.37	
68	S08660001	1	マフリト"メイタ	STOPPER PLATE	
69	062670812	2	ナヘ"コ357-40X8	SCREW 357X8	
70	S09320001	1	ヌノカ"イト"	CLOTH GUIDE	
71	107419002	1	シメネシ"4.37	SCREW 4.37	
72	100645003	1	サ"カ"ネ	WASHER	
73	S09319001	1	メスホルダ"カハ-	KNIFE HOLDER COVER	
74	115166001	2	タ"ンネシ"4.37	STUD SCREW 4.37	

A. 主体関係 / Machine body

CB2710-0011, 0021, 0031, 00T1
-00T2, 00U1, 00U2
CB2720-0011, 0021, 0031

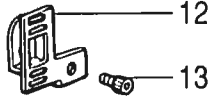

CB2710-0011, 0031, 00T1, 00T2
-00U1, 00U2
CB2720-0011, 0031



CB2710-0011, 0021, 0031, 00T1, 00T2
CB2720-0011, 0021, 0031

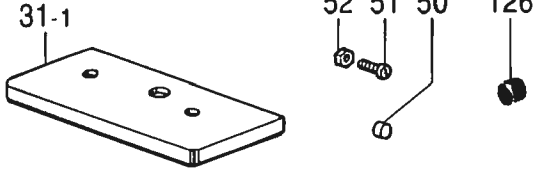

CB2710-0011, 0021, 0031, 0071, 007□ (□は1を除く), 00T1, 00T2
CB2720-0011, 0021, 0031, 0071, 007□ (□は1を除く) / 007□-except 1

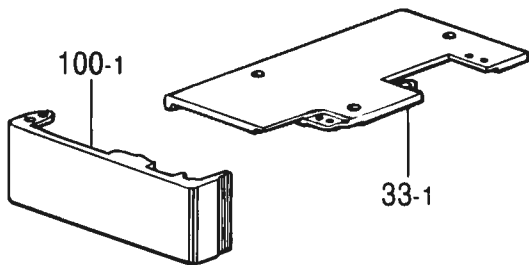

CB2710-0011, 0031, 00T1, 00T2
CB2720-0011, 0031

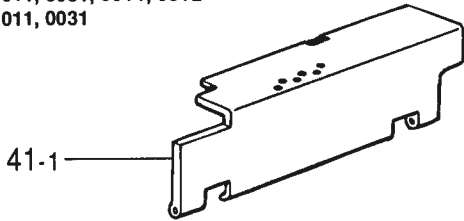

CB2710, 2720-0021

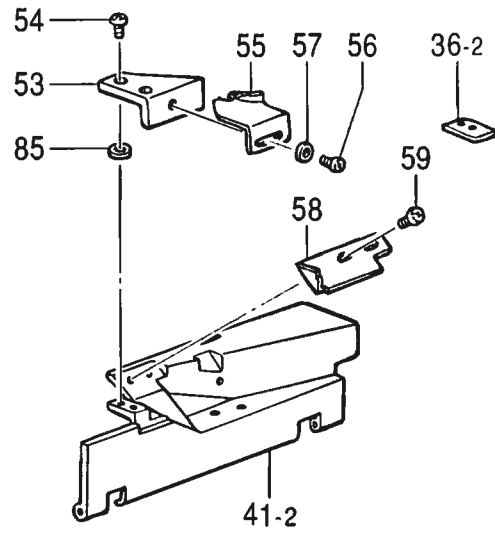

CB2710-00U1, 00U2

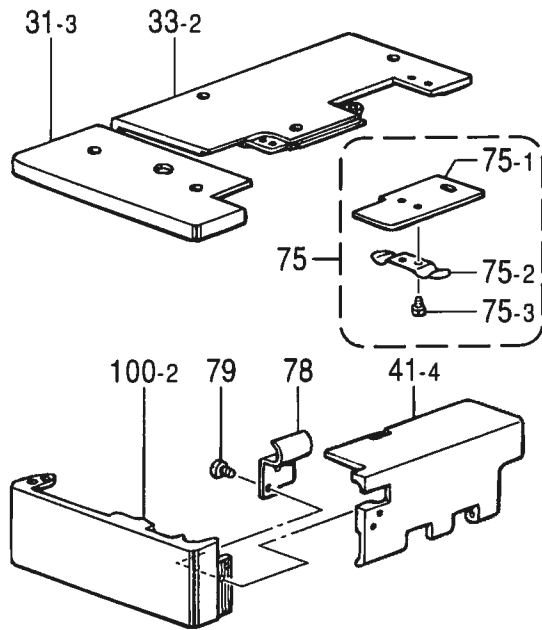

CB2710, 2720-0071, 007□ (□は1を除く) / 007□-except 1

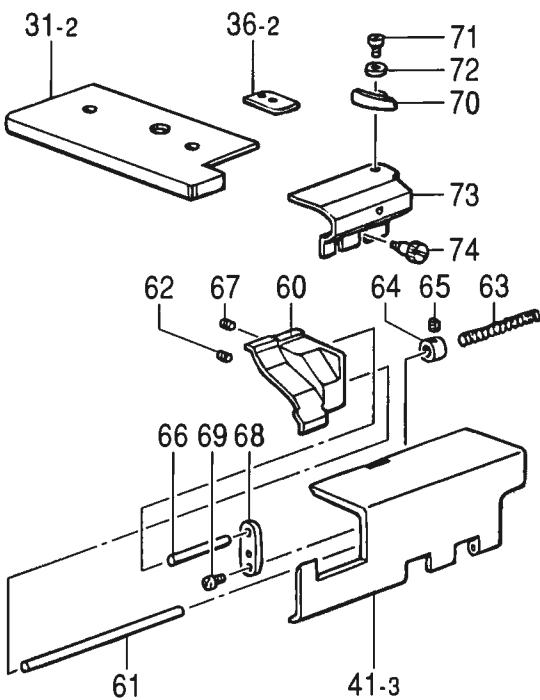

CB2710-0026-100

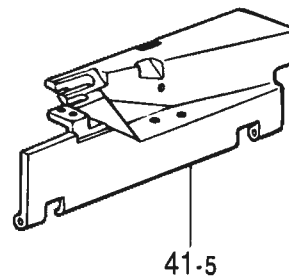

A. 主体関係/ Machine body

REF NO	CODE	Q'TY	ヒンメイ	NAME OF PARTS	RMKS
< FOR CB2710-00U1, 00U2 >					
31 3	S08636101	1	クロスプレートL	CLOTH PLATE (L)	
33 2	S08638001	1	クロスプレートR	CLOTH PLATE (R)	
41 4	S08650001	1	マエカバー	FRONT COVER	
75	S09193001	1	スベリイタクミ	SLIDE PLATE ASSEMBLY	
75-1	S08662001	1	スベリイタ	SLIDE PLATE	
75-2	S08663001	1	スベリイタウラハネ	SLIDE PLATE SPRING	
75 3	122771002	2	シメネジ"2.38	SCREW 2.38	
78	S08664001	2	チヨウセツネジ"カバー	ADJUST SCREW COVER	
79	123185001	4	マルヒラネジ"3.57X4.5	SCREW 3.57X4.5	
100 2	S08666001	1	ヨコカバー	SIDE COVER	
< FOR CB2710-0026-100 >					
41 5	S17477001	1	マエカバー	FRONT COVER	

B. 上軸・針棒関係 / Upper shaft and needle bar mechanism

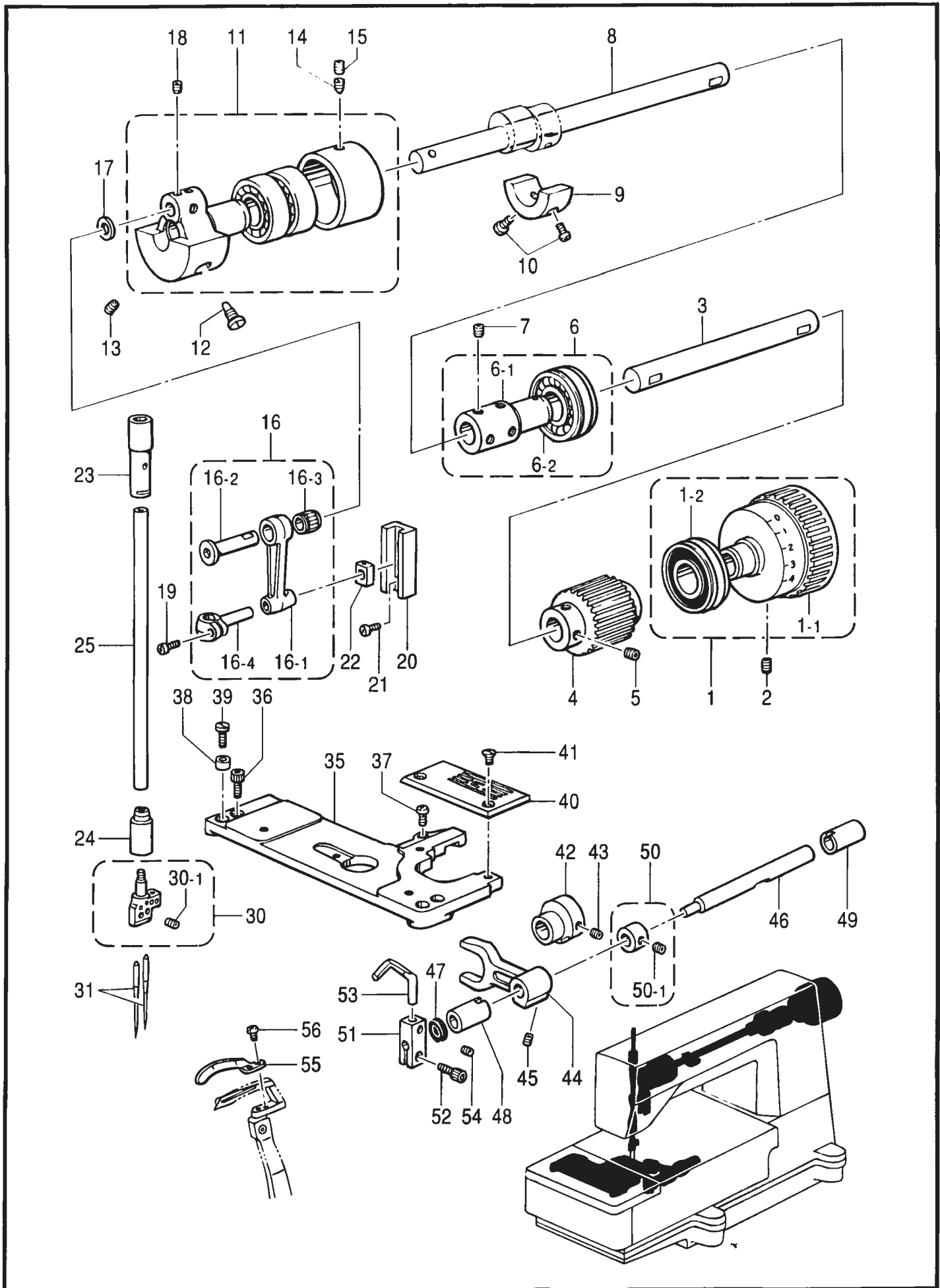

B. 上軸・針棒関係/Upper shaft and needle bar mechanism

REF NO	CODE	Q'TY	ヒンメイ	NAME OF PARTS	RMKS
1	S08679109	1	プーリクミ	PULLEY ASSEMBLY	
1 1	S08680009	1	プーリ	PULLEY	
1-2	S14621001	1	タマシ"クウケ6204LLB	BALL BEARING 6204LLB	
2	014770622	2	アナトメネシ"6.35クホ"ミ	SET SCREW 6.35	
3	S08682001	1	ウフシ"クR	UPPER SHAFT (R)	
4	S08683000	1	タイミンク"プーリU	TIMING PULLEY (U)	
5	014770622	4	アナトメネシ"6.35クホ"ミ	SET SCREW 6.35	
6	S08684101	1	ツキ"テLクミ	JOINT (L) ASSEMBLY	
6-1	S08685001	1	ツキ"テL	JOINT (L)	
6-2	S08686101	1	タマシ"クウケ6204LU	BALL BEARING 6204LU	
7	014770622	4	アナトメネシ"6.35クホ"ミ	SET SCREW 6.35	
8	S08687001	1	ウフシ"クL	ARM SHAFT (L)	
9	S08688001	1	ウエイト	WEIGHT	
10	062711012	2	ナヘ"コ476-32X10	SCREW 476X10	
11	S08689001	1	テンヒ"ンクランククミ	NEEDLE BAR CRANK ASSEMBLY	
12	104464001	1	シメネシ"7.14	SCREW 7.14	
13	014770622	1	アナトメネシ"6.35クホ"ミ	SET SCREW 6.35	
14	118853001	1	アナトメネシ"5.95	SET SCREW 5.95	
15	014760622	1	アナトメネシ"5.95	SET SCREW 5.95	
16	S08692101	1	ハリホ"ウレンカンクミ	THREAD TACK-UP LEVER ROD ASSEMBLY	
16-1	S08693001	1	ハリホ"ウレンカン	THREAD TACK-UP LEVER	
16-2	S08694001	1	ハリホ"ウレンカンジ"ク	THREAD TACK-UP LEVER SHAFT	
16-3	S09120001	1	ニート"ルジ"クウケ	NEEDLE ROLLER BEARING	
16-4	S08695001	1	ハリホ"ウタ"キ	NEEDLE BAR CLAMP	
16-5	100064005	1	シメネシ"3.57	SCREW 3.57	
17	107153001	1	サ"ガ"ネ	WASHER	
18	014760622	3	アナトメネシ"5.95	SET SCREW 5.95	
20	145688000	1	ハリホ"ウアンナイ	NEEDLE BAR GUIDE	
21	062670612	2	ナヘ"コ357-40X6	SCREW 357X6	
22	102630001	1	ハリホ"ウアンナイカクコマ	NEEDLE BAR GUIDE SLIDE BLOCK	
23	S08696000	1	ハリホ"ウメタルU	NEEDLE BAR BUSH (U)	
24	S08697000	1	ハリホ"ウメタルD	NEEDLE BAR BUSH (D)	
25	S08698001	1	ハリホ"ウ	NEEDLE BAR	
30	*	1	ハリト"メクミ	NEEDLE CLAMP ASSEMBLY	
35	S08716201	1	ハリイタササエイタ	NEEDLE PLATE SUPPORT PLATE	
36	018681022	2	アナホ"ルト4.37X10	BOLT 4.37X10	
37	062680812	1	ナヘ"コ437-40X8	SCREW 437X8	
38	S09124001	2	ハリイタササエイタカラー	COLLER	
39	S13385001	2	シメネシ"3.57X10	SCREW 3.57X10	
40	*	1	ハリイタ	NEEDLE PLATE	
41	S09121001	2	マルサラネシ"3.57X6	SCREW 3.57X6	
42	S08750001	1	ハリウケBヘンシンリン	NEEDLE GUARD REAR ECCENTRIC WHEEL	
43	014680622	2	アナトメネシ"4.37クホ"ミ	SET SCREW 4.37	
44	S08751001	1	ハリウケBレハ"ー	NEEDLE GUARD REAR LEVER	
45	014680622	2	アナトメネシ"4.37クホ"ミ	SET SCREW 4.37	
46	S08752001	1	ハリウケBシ"ク	NEEDLE GUARD REAR SHAFT	
47	155539000	1	ダ"ストシール	DUST SEAL	
48	S08753000	1	ハリウケBシ"クメタルL	KNIFE DRIVING SHAFT BUSH (L)	
49	S08754000	1	ハリウケBシ"クメタルR	KNIFE DRIVING SHAFT BUSH (R)	
50	S03704001	1	セツトカラー"クミ	SET COLLAR ASSEMBLY	
50-1	014770622	2	アナトメネシ"6.35クホ"ミ	SET SCREW 6.35	
51	S08755001	1	ハリウケBトリツク"ダイ	NEEDLE GUARD REAR SET BRACKET	
52	018681022	1	アナホ"ルト4.37X10	BOLT 4.37X10	
53	S08756001	1	ハリウケB	NEEDLE GUARD REAR	
54	014680422	1	アナトメネシ"4.37クホ"ミ	SET SCREW 4.37	
55	S08757001	1	イトウケ	THREAD GUARD	
56	060630312	1	ハ"イント"238-56X3	SCREW 238X3	

B . 上軸・針棒関係 / Upper shaft and needle bar mechanism

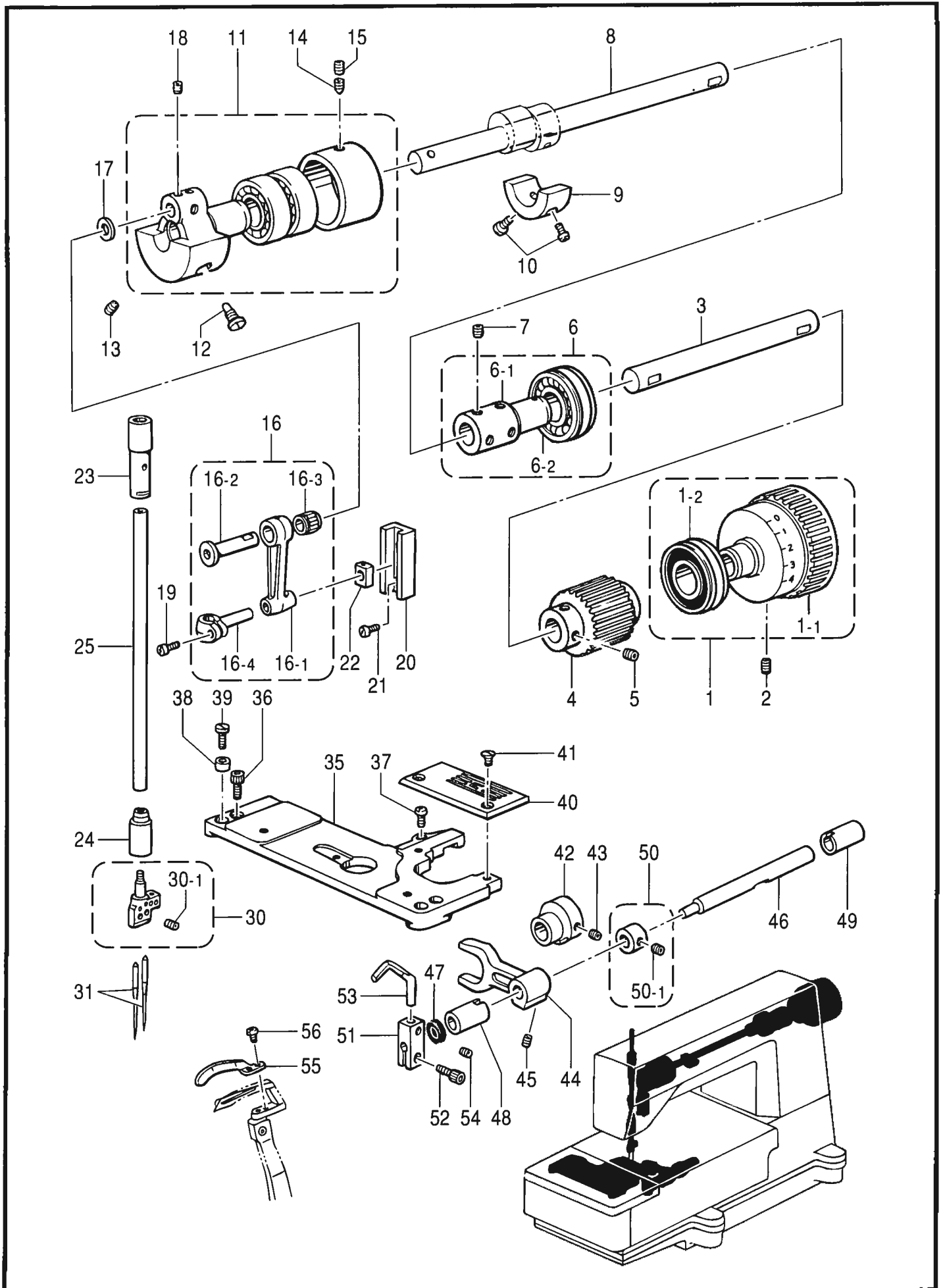

B. 上軸・針棒関係 / Upper shaft and needle bar mechanism

REF NO	CODE	Q'TY	ヒンメイ	NAME OF PARTS	RMKS
< FOR CB2710, 2720-0011, 0021, 0031, 0071, 007 -232, -240, -248, -256, -264 (は1を除く) / 007 - except 1 >					
30-1	146427001	2	アナトメネジ"3.18クボ"ミ	SET SCREW 3.18	
31	S08715010	2	ミシンハリUYX128GAS	NEEDLE UYX128GAS	
< FOR CB2710, 2720-0011, 0021, 0031, 0071, 007 -348, -356, -364 (は1を除く) / 007 - except 1 >					
30-1	146427001	3	アナトメネジ"3.18クボ"ミ	SET SCREW 3.18	
31	S08715010	3	ミシンハリUYX128GAS	NEEDLE UYX128GAS	
< FOR CB2710-00T1, 00U1 >					
30-1	146427001	2	アナトメネジ"3.18クボ"ミ	SET SCREW 3.18	
31	S08715014	2	ミシンハリUYX128GAS	NEEDLE UYX128GAS	
< FOR CB2710-00T2, 00U2 >					
30-1	146427001	2	アナトメネジ"3.18クボ"ミ	SET SCREW 3.18	
31	S08715018	2	ミシンハリUYX128GAS	NEEDLE UYX128GAS	

C . 押工關係 / Presser foot mechanism

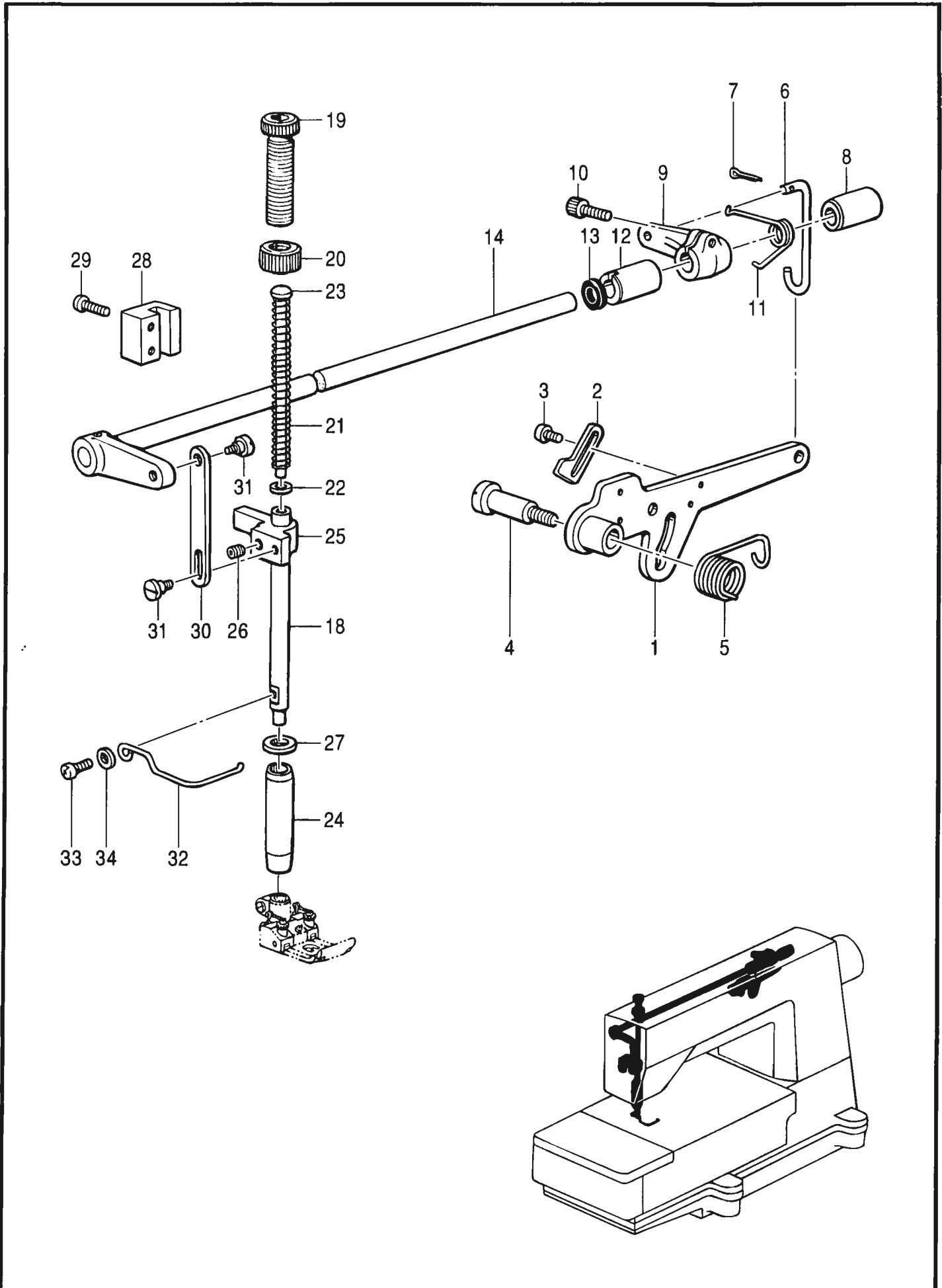

118-271-201

C. 押工関係/Presser foot mechanism

REF NO	CODE	Q'TY	ヒンメイ	NAME OF PARTS	RMKS
1	S08767001	1	オサエアケ"レハ"ーR	PRESSER BAR LIFTER LEVER (R)	
2	S08768001	1	オサエアケ"ストツハ"	PRESSER BAR LIFTER LEVER STOPPER	
3	060680712	2	ハ"イント"437-40X7	SCREW 4.37X7	
4	148372001	1	タ"ンネジ"7.94	STUD SCREW 7.94	
5	143325001	1	オサエアシアケ"レハ"ーハ"ネ	SPRING	
6	S08769001	1	オサエアケ"リンク	PRESSER LIFTER LINK	
7	110793001	1	フリピン	SPLIT PIN	
8	155220000	1	ホシ"ヨアツメタルR	AUTO PRESSER ARM BUSH (R)	
9	154956001	1	オサエアシアケ"Mレハ"ー	PRESSER BAR LIFTER INSIDE LEVER	
10	018771432	1	アナホ"ルト635-40X14	BOLT 635X14	
11	154957001	1	オサエアケ"Mレハ"ーハ"ネ	SPRING	
12	S08770000	1	シ"クメタル	NEEDLE THREAD TAKE-UP SHAFT BUSH (F)	
13	155539000	1	タ"ストシール	DUST SEAL	
14	S08771001	1	オサエアケ"レハ"ーLクミ	PRESSER BAR LIFTER LEVER (L) ASSEMBLY	
18	S08774001	1	オサエホ"ウ	PRESSER BAR	
19	141207001	1	オサエチヨウセツネジ"	PRESSER ADJUST SCREW	
20	147846002	1	チヨウセツネジ"ツマミナツト	NUT	
21	141728001	1	オサエハ"ネ	PRESSER BAR SPRING	
22	140407001	1	サ"カ"ネ	WASHER	
23	141208001	1	オサエハ"ネアンナイ	PRESSER SPRING GUIDE	
24	145472001	1	オサエホ"ウメタル	PRESSER BAR BUSH	
25	S00879001	1	オサエホ"ウタ"キ	PRESSER BAR GUIDE CLAMP	
26	014760622	1	ア"トメネジ"5.95	SET SCREW 5.95	
27	154596000	1	イトキリカムレハ"ークツシヨ	CUSHION	
28	S08775000	1	オサエホ"ウアンナイ	PRESSER BAR GUIDE	
29	062681412	2	ナ"ヘ"コ437-40X14	SCREW 437X14	
30	S08776001	1	オサエアケ"イタ	PRESSER BAR LIFTER PLATE	
31	S08777001	2	タ"ンネジ"4.37	STUD SCREW 4.37	
32	S08778000	1	フインガ"ーガ"ート"	FINGER GUARD	
33	062670812	1	ナ"ヘ"コ357-40X8	SCREW 357X8	
34	102707002	1	サ"カ"ネ	WASHER	

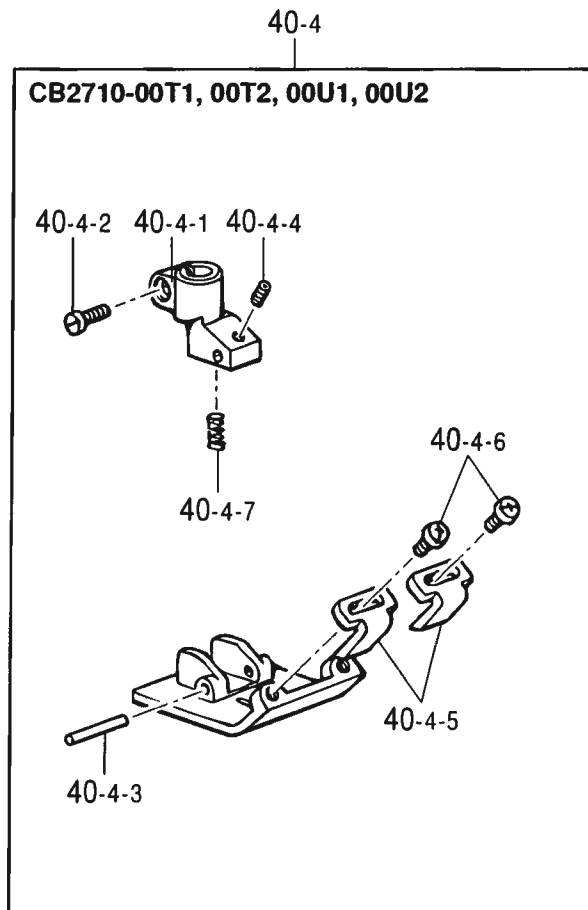
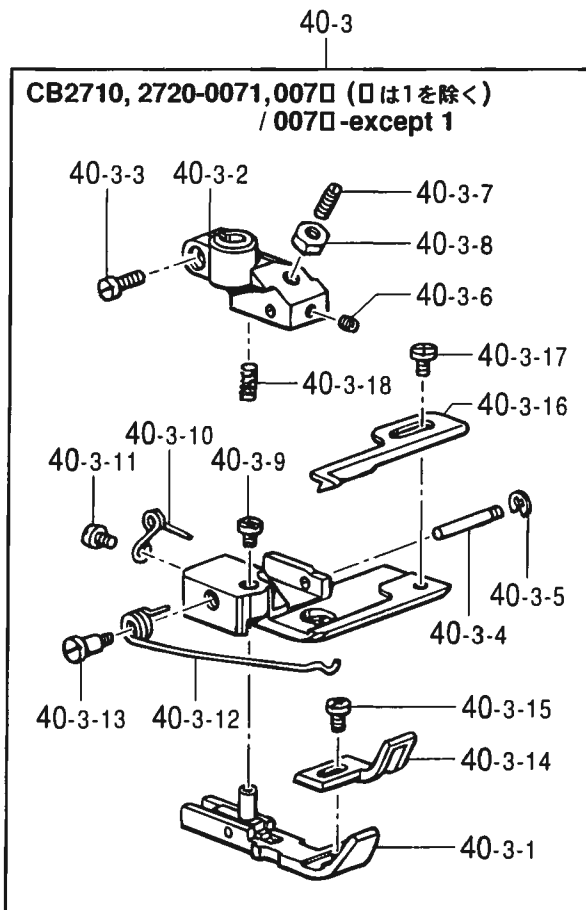
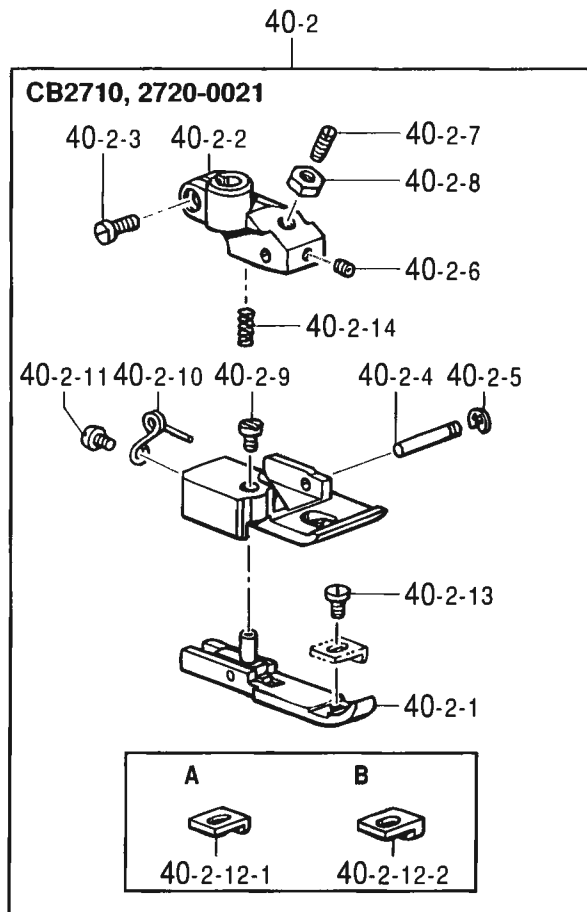
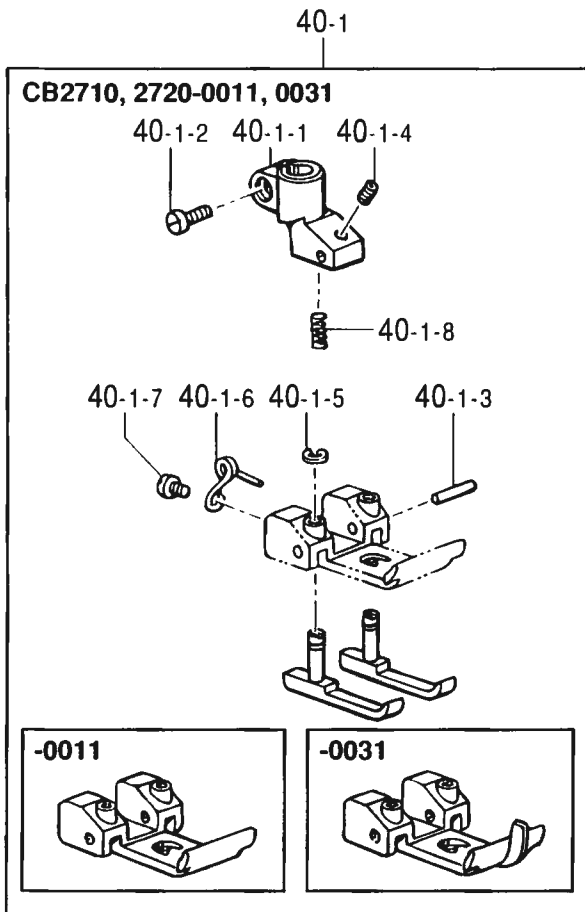

C. 押工関係 / Presser foot mechanism

REF NO	CODE	Q'TY	品名	NAME OF PARTS	RMKS
< FOR CB2710, 2720-0011, 0031 >					
40-1	*	1	オサイクミ	PRESSER FOOT ASSEMBLY	
40-1-1	S08782101	1	オサエシ"タイ	PRESSER FOOT BASE	
40-1-2	100064005	1	シメネシ"3.57	SCREW 3.57	
40-1-3	S08783101	1	オサエピン	PIN	
40-1-4	S01374001	1	トメネシ"2.38クホ"ミ	SET SCREW 2.38	
40-1-5	048020342	2	トメフE2	STOP RING E2	
40-1-6	S08784001	2	オサエハ"ネ	SPRING	
40-1-7	062660512	2	ナヘ"コネシ"318-40X5	SCREW 318X5	
40-1-8	S08785001	1	オシハ"ネ	SPRING	
< FOR CB2710, CB2720-0021 >					
40-2	*	1	オサイクミ	PRESSER FOOT ASSEMBLY	
40-2-1	S08802101	1	ハシオサイクミ	EDGE PRESSER ASSEMBLY	
40-2-2	S08806101	1	オサエシ"タイ	PRESSER FOOT BASE	
40-2-3	100064005	1	シメネシ"3.57	SCREW 3.57	
40-2-4	S08807101	1	オサエピン	PIN	
40-2-5	048015346	1	トメフE1.5	STOP RING E1.5	
40-2-6	146427001	1	アナトメネシ"3.18クホ"ミ	SET SCREW 3.18	
40-2-7	S08808001	1	ストップ"ネシ"	STOPPER SCREW	
40-2-8	021660102	1	ナツト1シユ3.18	NUT 3.18	
40-2-9	S08809001	1	シメネシ"2.38X3.5	SCREW 2.38X3.5	
40-2-10	S08810001	1	オサエネシ"リハ"ネ	SPRING	
40-2-11	060630412	1	ハ"イント"238-56X4	SCREW 238X4	
40-2-12-1	S08817101	1	ガ"イト"A 021-3.4.5.6.7.8	GUIDE (A) (FOR 021-3.4.5.6.7.8)	
40-2-12-2	S08811101	1	ガ"イト"B(021-1.2)	GUIDE (B) (FOR 021-1.2)	
40-2-13	141544001	1	シメネシ"3.18	SCREW 3.18	
40-2-14	S08812001	1	オシハ"ネ	SPRING	
< FOR CB2710, CB2720-0071, 0071 (□は1を除く) / 0071] - except 1 >					
40-3	*	1	オサイクミ	PRESSER FOOT ASSEMBLY	
40-3-1	S08842101	1	ハシオサイクミ	EDGE PRESSER ASSEMBLY	
40-3-2	S08806101	1	オサエシ"タイ	PRESSER FOOT BASE	
40-3-3	100064005	1	シメネシ"3.57	SCREW 3.57	
40-3-4	S08807101	1	オサエピン	PIN	
40-3-5	048015346	1	トメフE1.5	STOP RING E1.5	
40-3-6	146427001	1	アナトメネシ"3.18クホ"ミ	SET SCREW 3.18	
40-3-7	S08808001	1	ストップ"ネシ"	STOPPER SCREW	
40-3-8	021660102	1	ナツト1シユ3.18	NUT 3.18	
40-3-9	S08809001	1	シメネシ"2.38X3.5	SCREW 2.38X3.5	
40-3-10	S08810001	1	オサエネシ"リハ"ネ	SPRING	
40-3-11	060630412	1	ハ"イント"238-56X4	SCREW 2.38X4	
40-3-12	S08844101	1	オサエハ"ネ	SPRING	
40-3-13	155103001	1	タ"ンネシ"3.18	STUD SCREW 3.18	
40-3-14	S08845101	1	ガ"イト"F	GUIDE (F)	
40-3-15	062670412	1	ナヘ"コ357-40X4	SCREW 357X4	
40-3-16	S08846101	1	ガ"イト"B	GUIDE (B)	
40-3-17	S16244001	1	シメネシ"3.57	SCREW 3.57	
40-3-18	S08812001	1	オシハ"ネ	SPRING	
< FOR CB2710-00T1, 00T2, 00U1, 00U2 >					
40-4	*	1	オサイクミ	PRESSER FOOT ASSEMBLY	
40-4-1	S08782101	1	オサエシ"タイ	PRESSER FOOT BASE	
40-4-2	100064005	1	シメネシ"3.57	SCREW 3.57	
40-4-3	S08864101	1	オサエピン	PIN	
40-4-4	S01374001	1	トメネシ"2.38クホ"ミ	SET SCREW 2.38	
40-4-5	S08865101	2	オサエガ"イト"	PRESSER GUIDE	
40-4-6	062660512	2	ナヘ"コネシ"318-40X5	SCREW 318X5	
40-4-7	S08785001	1	オシハ"ネ	SPRING	

C. 押工関係 / Presser foot mechanism

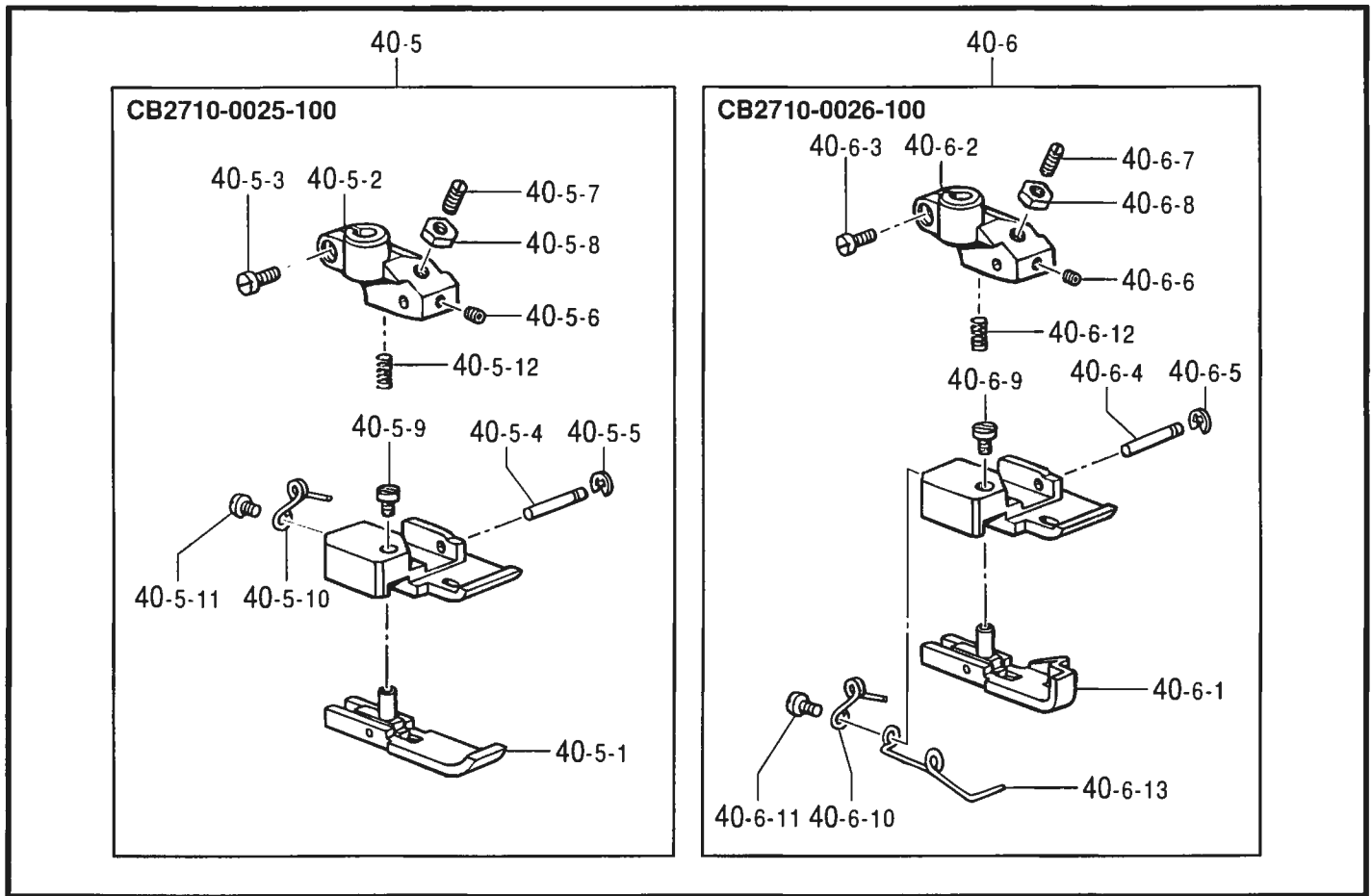

118-271-201

D. 針冷却関係 / Needle cooler

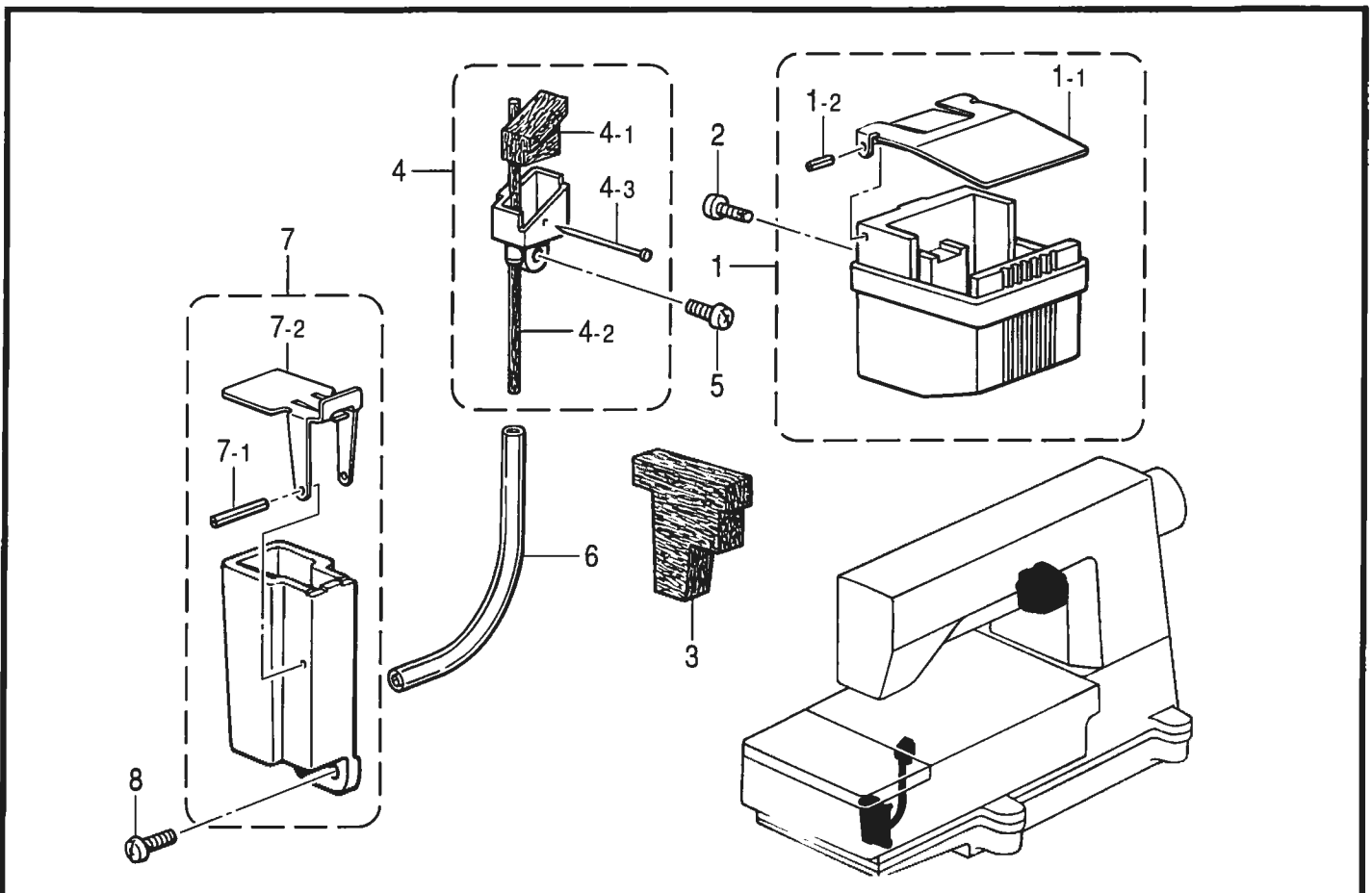

118-271-124

C. 押工関係/Presser foot mechanism

REF.NO.	CODE	Q'TY	ヒンメイ	NAME OF PARTS	RMKS
< FOR CB2710-0025-100 >					
40-5	*	1	オサイクミ	PRESSER FOOT ASSEMBLY	
40-5-1	S17486001	1	ハシオサイクミ	EDGE PRESSER ASSEMBLY	
40-5-2	S08806101	1	オサエシジ"タイ	PRESSER FOOT BASE	
40-5-3	100064005	1	シメネジ"3.57	SCREW 3.57	
40-5-4	S08807101	1	オサエピン	PIN	
40-5-5	048015346	1	トメワE1.5	STOP RING E1.5	
40-5-6	146427001	1	アナトメネジ"3.18クホ"ミ	SET SCREW 3.18	
40-5-7	S08808001	1	ストップネジ"	STOPPER SCREW	
40-5-8	021660102	1	ナツト1シユ3.18	NUT 3.18	
40-5-9	S08809001	1	シメネジ"2.38X3.5	SCREW 2.38X3.5	
40-5-10	S17488001	1	オサエネジ"リハ"ネ	SPRING	
40-5-11	060630412	1	ハ"イント"238-56X4	SCREW 238X4	
40-5-12	S08812001	1	オシハ"ネ	SPRING	
< FOR CB2710-0026-100 >					
40-6	*	1	オサイクミ	PRESSER FOOT ASSEMBLY	
40-6-1	S17491001	1	ハシオサイクミ	EDGE PRESSER ASSEMBLY	
40-6-2	S08806101	1	オサエシジ"タイ	PRESSER FOOT BASE	
40-6-3	100064005	1	シメネジ"3.57	SCREW 3.57	
40-6-4	S08807101	1	オサエピン	PIN	
40-6-5	048015346	1	トメワE1.5	STOP RING E1.5	
40-6-6	146427001	1	アナトメネジ"3.18クホ"ミ	SET SCREW 3.18	
40-6-7	S08808001	1	ストップネジ"	STOPPER SCREW	
40-6-8	021660102	1	ナツト1シユ3.18	NUT 3.18	
40-6-9	S08809001	1	シメネジ"2.38X3.5	SCREW 2.38X3.5	
40-6-10	S17488001	1	オサエネジ"リハ"ネ	SPRING	
40-6-11	111105002	1	シメネジ"2.38	SCREW 2.38	
40-6-12	S08812001	1	オシハ"ネ	SPRING	
40-6-13	S17493001	1	ハシオサエハ"ネ	SPRING	

D. 針冷却装置/Needle cooler

REF.NO.	CODE	Q'TY	ヒンメイ	NAME OF PARTS	RMKS
1	S08758009	1	ハライトレイキヤクタンククミ	NEEDLE THREAD COOLER TANK ASSEMBLY	
1-1	S08760009	1	ハライトレイキヤクタンクフタ	NEEDLE THREAD COOLER TANK COVER	
1-2	047200642	2	スプリング"ピン"AW2	SPRING PIN AW2	
2	575456001	2	+ナヘ"P"タイト3X10	SCREW 3X10	
3	S08761000	1	ハライトレイキヤクフエルト	NEEDLE THREAD COOLER FELT	
4	S08762101	1	フェルトササイクミ	FELT SUPPORT ASSEMBLY	
4-1	S08764100	1	フェルトS	FELT (S)	
4-2	S08765000	1	フェルト	FELT	
4-3	S02874001	1	ムシピン	PIN	
5	062670812	2	ナヘ"コ357-40X8	SCREW 357X8	
6	S08766000	1	ビ"ニルチューブ"	VINYL TUBE	
7	154943001	1	ハライトレイキヤクタンククミ	NEEDLE COOLER TANK ASSEMBLY	
7-1	047201640	1	スプリング"ピン"AW2	SPRING PIN AW2	
7-2	154945001	1	ハライトレイキヤクタンクフタ	NEEDLE COOLER TANK COVER	
8	062670812	2	ナヘ"コ357-40X8	SCREW 357X8	

E. 送り関係 / Feed mechanism

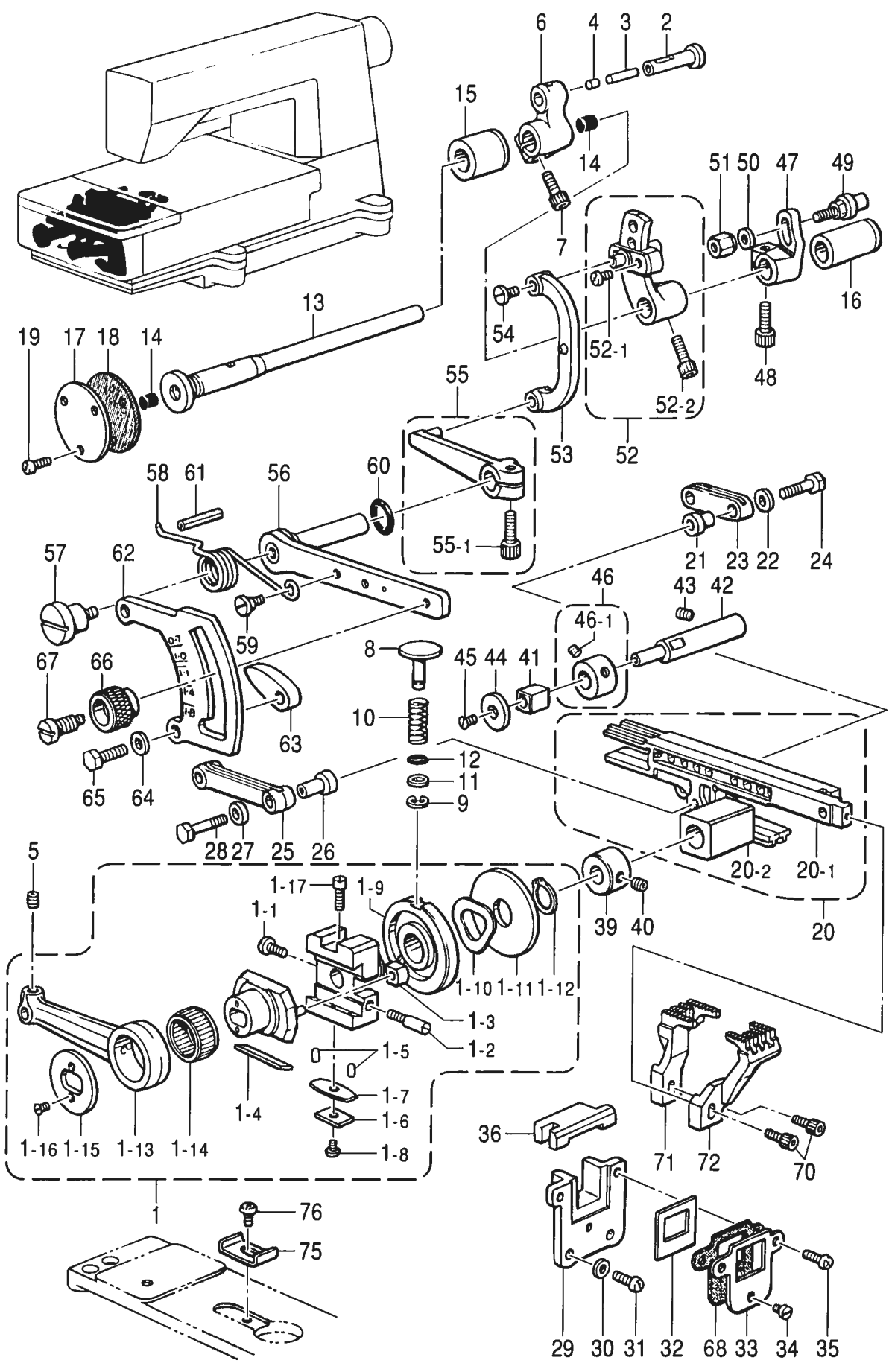

E. 送り関係 / Feed mechanism

REF NO	CODE	Q'TY	ヒンメイ	NAME OF PARTS	RMKS
1	146528102	1	ヘンシンリンクミ	ECCENTRIC WHEEL ASSEMBLY	
1-1	S16498001	1	シメネジ"4.37	SCREW 4.37	
1-2	145663001	1	トメネジ"4.37	SET SCREW 4.37	
1-3	140165001	1	チヨウセツヒンカワコマ	SLIDE BLOCK	
1-4	146401001	1	シ"フ"	GIB	
1-5	146402002	2	シ"フ"オサエヒン	GIB HOLDER PIN	
1-6	146403001	1	シ"フ"オサエイクハ"ネS	GIB HOLDER PLATE (S)	
1-7	146404001	1	シ"フ"オサエイタハ"ネL	GIB HOLDER PLATE (L)	
1-8	062660512	1	ナヘ"コネジ"318-40X5	SCREW 318X5	
1-9	144053001	1	ヘンシンチヨウセツカムクミ	ECCENTRIC WHEEL ADJUST CAM ASSEMBLY	
1-10	144055001	1	ナミハ"ネ	WAVE SPRING	
1-11	146529001	1	サ"ガ"ネ	WASHER	
1-12	048150143	1	トメフシ"クヨウC15	STOP RING C15	
1-13	146530001	1	オクリロツト"	FEED ROD	
1-14	146531001	1	ニート"ルジ"クウケ20	NEEDLE ROLLER BEARING 20	
1-15	140176001	1	オクリロツト"オサエイタ	FEED ROD PRESSER PLATE	
1-16	117517003	2	サラネジ"2.38	SCREW 2.38	
1-17	100025002	2	シメネジ"4.76	SCREW 4.76	
2	146532001	1	オクリロツト"ヒン	FEED ROD PIN	
3	147318000	1	ヒン	PIN	
4	140326009	1	ゴムセン	OIL CAP	
5	100251001	1	トメネジ"6.35	SET SCREW 6.35	
6	146533001	1	オクリウテ"	FEED ARM	
7	018771432	1	アナホ"ルト635-40X14	BOLT 635X14	
8	S08870001	1	フ"ツシユホ"タン	PUSH BUTTON	
9	048040342	1	トメフE4	STOP RING E4	
10	S08871001	1	ホ"タンシ"クハ"ネ	BUTTON SHAFT SPRING	
11	153484001	1	サ"ガ"ネ4.76	WASHER 4.76	
12	081003670	1	Oリング"PW3	O RING PW3	
13	146538001	1	オクリシ"ク	FEED SHAFT	
14	140327001	2	ゴムセン	OIL CAP	
15	146539000	1	オクリシ"クメタルL	FEED SHAFT BUSH (L)	
16	146540000	1	オクリシ"クメタルR	FEED SHAFT BUSH (R)	
17	155144001	1	オクリシ"クメタルLフタ	FEED SHAFT BUSH (L) CAP	
18	155145000	1	パ"ツキン	PACKING	
19	062670812	3	ナヘ"コ3.57-40X8	SCREW 357X8	
20	S08872001	1	オクリタ"イカクゴ"マクミ	FEED BAR SLIDE BLOCK ASSEMBLY	
20-1	S08873001	1	オクリタ"イクミ	FEED BAR ASSEMBLY	
20-2	146544000	1	シ"ヨウケ"オクリカクゴ"マ	FEED LIFTER SLIDE BLOCK	
21	140207001	1	シユオクリリンクフ"シユ	MAIN FEED LINK BUSH	
22	140208001	1	サ"ガ"ネ	WASHER	
23	140209001	1	シユオクリリンク	MAIN FEED LINK	
24	140210001	1	シユオクリリンクシ"クス	MAIN FEED LINK SHAFT (S)	
25	146554001	1	サト"ウオクリリンク	DIFFERENTIAL FEED LINK	
26	146555001	1	サト"ウオクリリンクフ"シユ	DIFFERENTIAL FEED LINK BUSH	
27	140208001	1	サ"ガ"ネ	WASHER	
28	140217001	1	オクリリンクシ"クL	FEED LINK SHAFT (L)	
29	155151000	1	オクリタ"イアンナイ	FEED BAR GUIDE	
30	100645003	2	サ"ガ"ネ	WASHER	
31	062681012	2	ナヘ"コ437-40X10	SCREW 437X10	
32	155177100	1	ホ"ウジ"ンイタ	FRAGMENT PROTECTOR PLATE	
33	155178001	1	ホ"ウジ"ンイタササエ	FRAGMENT PROTECTOR SUPPRT	
34	S01297001	1	シメネジ"3.57X3.5	SCREW 3.57X3.5	
35	062681012	2	ナヘ"コ437-40X10	SCREW 437X10	
36	S08876000	1	オクリタ"イホ"ウシ"ンタイ	FEED BAR FRAGMENT PROTECTOR BASE	
39	146741000	1	セツトカラー	SET COLLAR	
40	101706001	1	トメネジ"6.35	SET SCREW 6.35	
41	146547000	1	オクリタ"イカクゴ"マ	FEED BAR SLIDE BLOCK	
42	146548101	1	オクリタ"イカクゴ"マシ"ク	FEED BAR SLIDE BLOCK SHAFT	
43	014780622	1	アトメネジ"6.35クホ"ミ	SET SCREW 6.35	
44	S08877001	1	オクリタ"イカクゴ"マアテイタ	SLIDE PLATE	
45	107272002	1	サラネジ"4.37	SCREW 4.37	

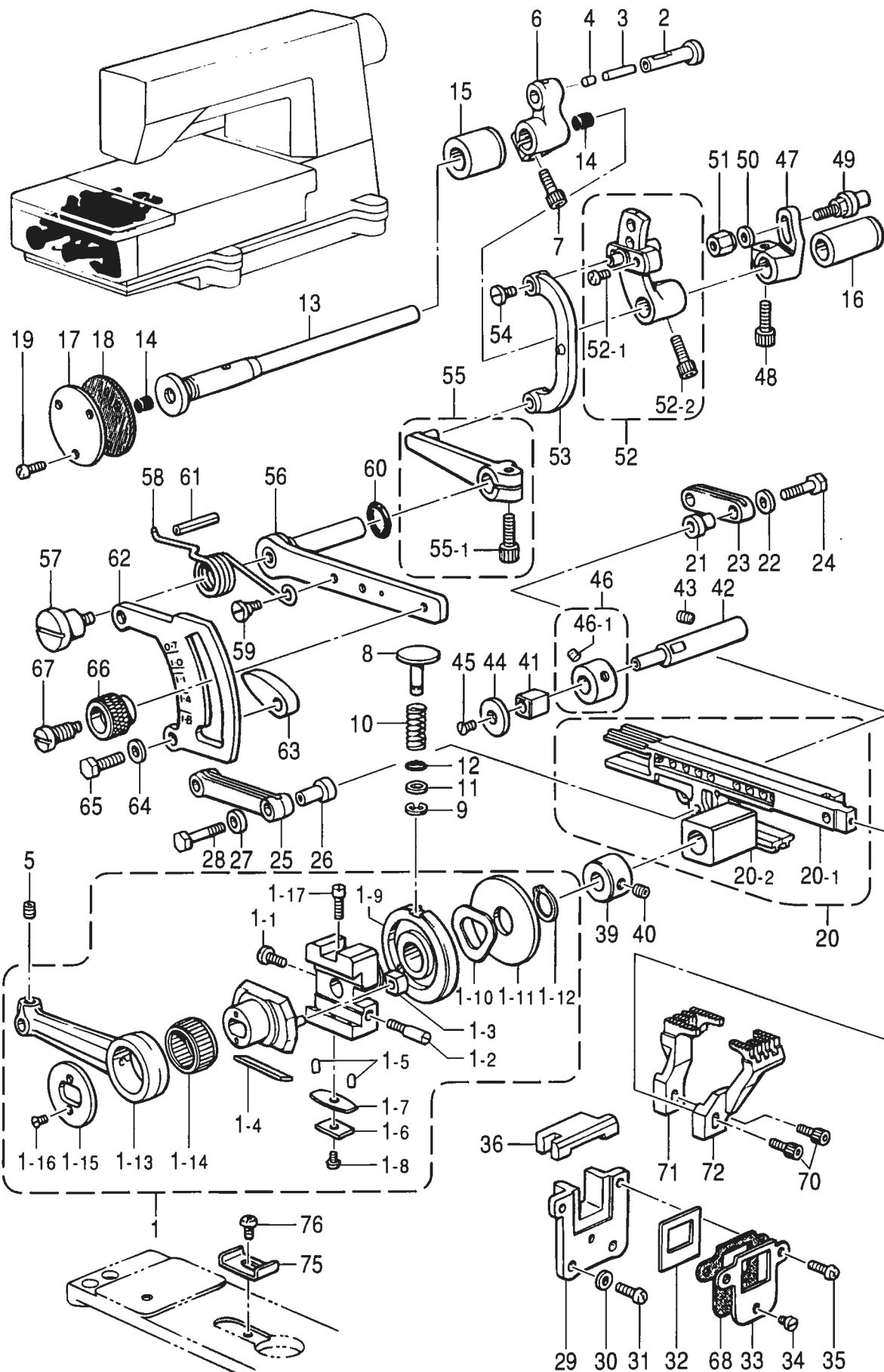

E. 送り関係 / Feed mechanism

REF NO	CODE	Q'TY	ヒンメイ	NAME OF PARTS	RMKS
46	S03704001	1	セツトカラークミ	SET COLLAR ASSEMBLY	
46-1	014770622	2	アナトメネジ"6.35クホ"ミ	SET SCREW 6.35	
47	140205001	1	シユオクリウテ"	MAIN FEED ARM	
48	018771432	1	アナホ"ルト635-40X14	BOLT 635X14	
49	143564001	1	シユオクリジ"ク	MAIN FEED SHAFT	
50	113431002	1	サ"カ"ネ	WASHER	
51	143565001	1	ナツト4.76	NUT 4.76	
52	S08878001	1	サト"ウオクリウテ"クミ	DIFFERENTIAL FEED ARM ASSEMBLY	
52-1	062660712	2	ナヘ"コ318-40X7	SCREW 318X7	
52-2	018771432	1	アナホ"ルト635-40X14	BOLT 635X14	
53	146556001	1	サト"ウリンク	DIFFERENTIAL FEED ADJUST LINK	
54	148834001	1	シメネジ"3.57	SCREW 3.57	
55	S08879001	1	リンクレハ"ーネジ"ツキ	DIFFERENTIAL FEED LINK LEVER ASSEMBLY	
55-1	018771432	1	アナホ"ルト635-40X14	BOLT 635X14	
56	S08880001	1	サト"ウチヨウセツレハ"ー	DIFFERENTIAL FEED ADJUST LEVER	
57	146559001	1	ダ"ンネジ"5.56	STUD SCREW 5.56	
58	146560101	1	レハ"ーハ"ネ	LEVER SPRING	
59	100294002	1	ダ"ンネジ"4.76	STUD SCREW 4.76	
60	109203001	1	Oリング"	O RING	
61	047502242	1	スフ"リンク"ヒンAW5	SPRING PIN AW5	
62	S08881101	1	サト"ウリヨウメモリイタ	DIFFERENTIAL STITCH CONTROL	
63	146563001	2	チヨウセツレハ"ーストツハ"	STOPPER FOR DIFFERENTIAL STITCH CONTROL	
64	025770232	2	ヒラサ"カ"ネチユウ6.35	PLAIN WASHER 6.35	
65	017781412	2	ホ"ルト6.35X14	BOLT 6.35X14	
66	155175001	1	セツトネジ"ツマミ	SET SCREW KNOB	
67	155176001	1	セツトネジ"	SET SCREW	
68	S08467000	1	ハ"ツキン	PACKING	
70	154965001	2	アナホ"ルト3.57X8	BOLT 3.57X8	
71	*	1	シユオクリハ"	MAIN FEED DOG	
72	*	1	サト"ウオクリハ"	DIFFERENTIAL FEED DOG	
75	S16249001	1	フ"ツシユホ"タンストツハ"	PUSH BUTTON STOPPER	
76	060680512	1	ハ"イント"437-40X5	SCREW 437X5	

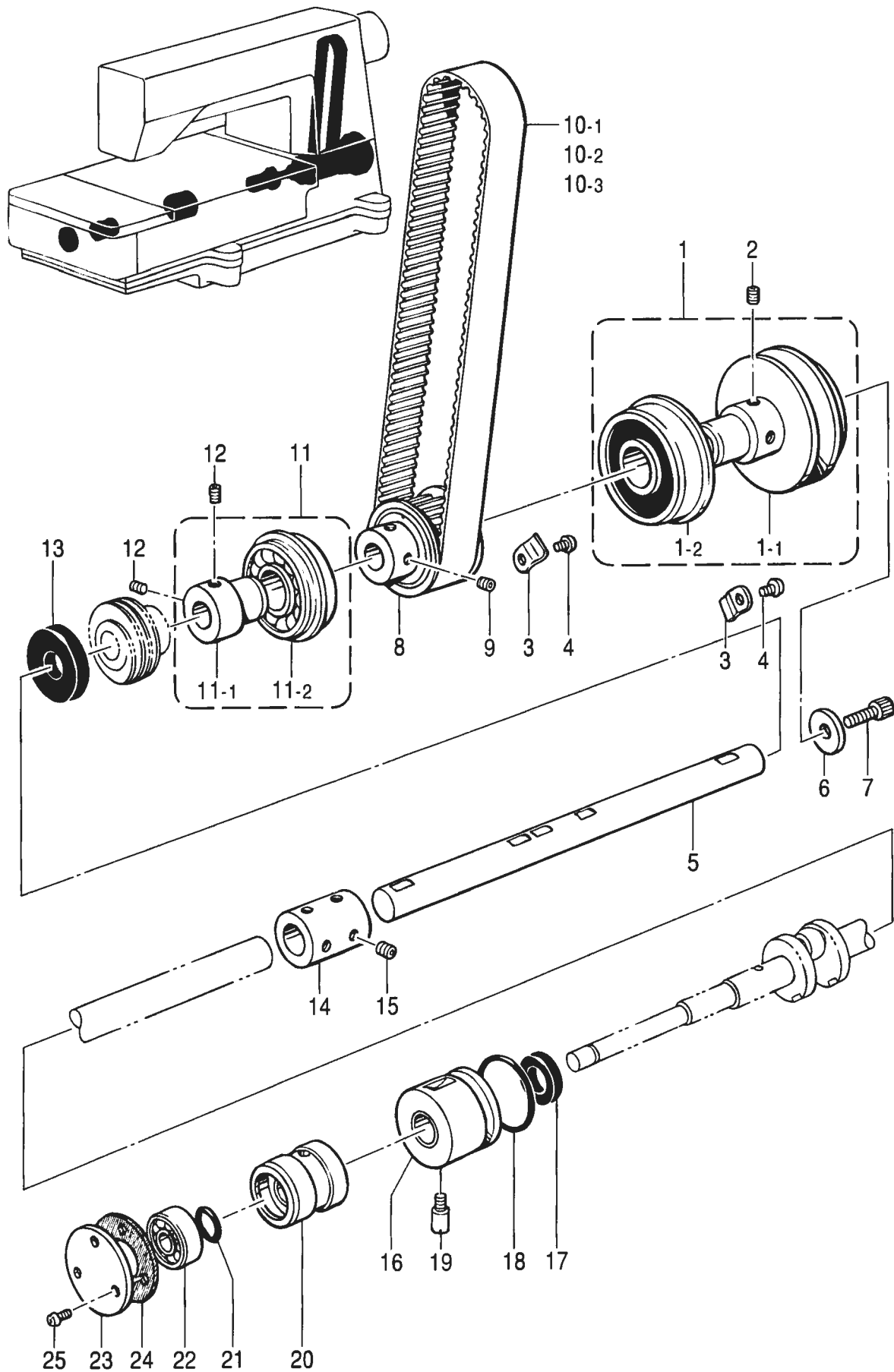

F. 下軸関係/Lower shaft mechanism

REF NO	CODE	Q'TY	ヒンメイ	NAME OF PARTS	RMKS
< FOR CB2710-0011, 0021, 0031, 0071, 00T1, 00T2, 00U1, 00U2 >					
< FOR CB2720-0011, 0021, 0031, 0071 >					
1	S08889101	1	Vベルトプーリクミ	V-BELT PULLEY ASSEMBLY	
1-1	S08890001	1	Vベルトプーリ	V-BELT PULLEY	
1-2	S14622001	1	タマシクウケ6304VV	BALL BEARING 6304VV	
< FOR CB2710-0011, 0021, 0031, 0071, 007 , 00T1, 00T2, 00U1, 00U2 (□は1を除く) / 007□ - except 1 >					
< FOR CB2720-0011, 0021, 0031, 0071, 007 (□ は1を除く) / 007□ - except 1 >					
2	014780622	2	アタメネジ6.35クホミ	SET SCREW 6.35	
3	153734001	2	アームササエイタハネ	ARM SUPPORT PLATE SPRING	
4	062680612	2	ナヘコ437-40X6	SCREW 437X6	
5	S08891001	1	シタシクR	LOWER SHAFT (R)	
6	154886001	1	サガネ	WASHER	
7	018771432	1	アナホルト635-40X14	BOLT 6.35X14	
8	S08892001	1	タイミングプーリDクミ	TIMING PULLEY (D) ASSEMBLY	
9	014770622	2	アタメネジ6.35クホミ	SET SCREW 6.35	
10-1	※ S08895001	1	タイミングベルト	TIMING BELT	
10-2	※ S08895002	1	タイミングベルト	TIMING BELT	
10-3	※ S08895003	1	タイミングベルト	TIMING BELT	
11	S08896101	1	タマシクウケクミ	BALL BEARING ASSEMBLY	
11-1	S08897001	1	タマシクウケブシ	BALL BEARING BUSH	
11-2	S14623001	1	タマシクウケ6204DU	BALL BEARING 6204DU	
12	014770622	2	アタメネジ6.35クホミ	SET SCREW 6.35	
13	S08898000	1	オイルシール	OIL SEAL	
14	S08899001	1	シクツキテ	SHAFT JOINT	
15	014770622	4	アタメネジ6.35クホミ	SET SCREW 6.35	
16	S08900000	1	クランクシクメタルRクミ	LOWER SHAFT BUSH (R) ASSEMBLY	
17	S08903000	1	ダストシール	DUST SEAL	
18	081032870	1	OリングS32	O RING S32	
19	S08967001	1	シメネジ4.76	SCREW 4.76	
20	S08904000	1	クランクシクメタルLクミ	LOWER SHAFT BUSH (L) ASSEMBLY	
21	114294001	1	Oリング	O RING	
22	072600000	1	タマシクウケ6000	BALL BEARING 6000	
23	143311001	1	ヘアリングフタ	BEARING COVER	
24	143312000	1	ヘアリングフタハツキン	BEARING COVER PACKING	
25	062670812	3	ナヘコ357-40X8	SCREW 357X8	

※印はアームベッド上面のテーキンに合せて御選択下さい。(取扱説明書、タイミングベルト交換の仕方を参照下さい。)

Select parts marked with a star (※) according to the index on the arm bed top. (Refer to timing belt replacement in the instruction manual.)

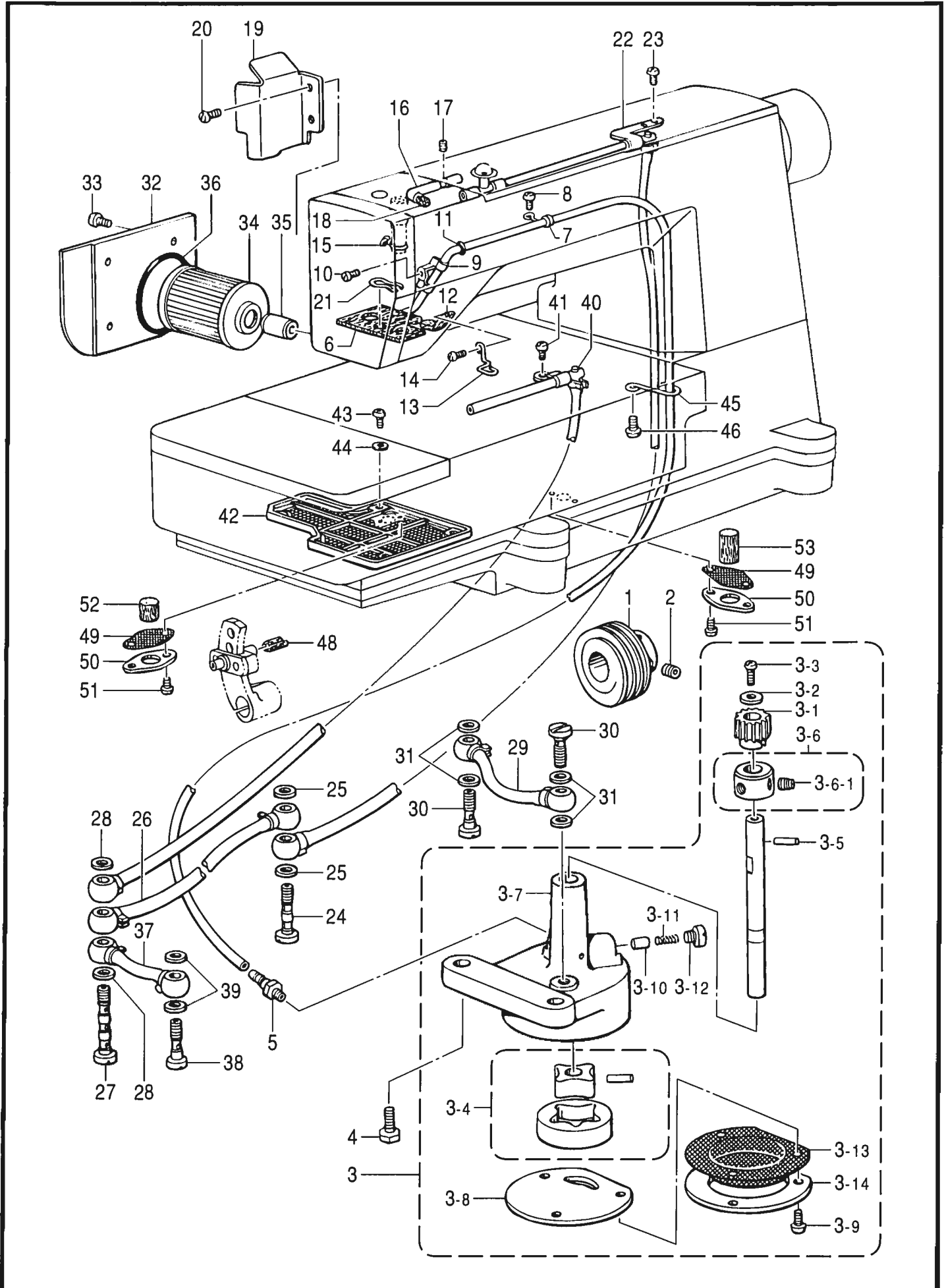

G. 給油潤滑関係 / Lubrication

REF NO	CODE	Q'TY	ヒンメイ	NAME OF PARTS	RMKS
1	S08935001	1	ウオーム	WORM	
2	014770622	2	アナトメネシ"6.35クホ"ミ	SET SCREW 6.35	
3	S08936101	1	トロコイト"ホ"ンフ"クミ	PUMP ASSEMBLY	
3-1	144619000	1	ウオームホイール	WORM WHEEL	
3-2	025350332	1	ヒラサ"カ"ネタ"イ3.5	PLAIN WASHER 3.5	
3-3	062670812	1	ナヘ"ユ357-40X8	SCREW 357X8	
3-4	S08937001	1	ホ"ンフ"ローター"クミ	PUMP INNER ROTER ASSEMBLY	
3-5	144622001	1	ミソ"ツキヒ"ンE"カ"タ	DOWEL PIN (E)	
3-6	181995001	1	セツト"カ"ラー"クミ	SET COLLAR ASSEMBLY	
3-6-1	101706001	2	トメネシ"6.35	SET SCREW 6.35	
3 7	S08939000	1	ホ"ンフ"ケース	PUMP CASE	
3-8	147527001	1	ホ"ンフ"フタ	PUMP COVER	
3-9	062671012	3	ナヘ"ユ357-40X10	SCREW 357X10	
3-10	144875001	1	フ"ランシ"ヤー	PLUNGER	
3-11	144876001	1	フ"ランシ"ヤー"ハ"ネ	PLUNGER SPRING	
3-12	112467002	1	シメネシ"6.35	SCREW 6.35	
3-13	147528100	1	ロカモウ	OIL FILTER	
3-14	147529001	1	ロカモウ"オ"サ"エ	OIL FILTER FLANGE	
4	017781412	2	ボ"ルト"6.35X14	BOLT 6.35X14	
5	142359001	1	オイルクチ	OIL FEEDING PIPE	
6	S08940000	1	チューブ"クミ	OIL TUBE ASSEMBLY	
7	112743001	1	クミヒモ"サ"サ"エ	WICK SUPPORT	
8	062670612	1	ナヘ"ユ357-40X6	SCREW 357X6	
9	151429001	1	チューブ"ホル"タ"	TUBE HOLDER	
10	062670612	1	ナヘ"ユ357-40X6	SCREW 357X6	
11	118770001	1	ハ"ツ"キン	PACKING	
12	S08943000	1	カクゴ"マ"フ"エ"ルト	FELT	
13	S08944001	1	フ"エ"ルト"オ"サ"エ	FELT PRESSER	
14	062670612	1	ナヘ"ユ357-40X6	SCREW 357X6	
15	157840000	1	クミヒモ"3X3	WICK 3X3 (L=100)	
16	S08945001	1	オイル"ハ"イ"フ"	OIL PIPE	
17	014680622	1	アナトメネシ"4.37クホ"ミ	SET SCREW 4.37	
18	S08946000	1	フ"エ"ルト	FELT	
19	S08947001	1	オイル"ヨ"ク"エ"イ"タ	OIL STOPPER PLATE	
20	062670612	2	ナヘ"ユ357-40X6	SCREW 357X6	
21	145737001	1	フ"エ"ルト"オ"サ"エ	FELT HOLDER	
22	S08948001	1	ロツト"オイル"ハ"イ"フ"ウ"ク"ミ	MAIN OIL PIPE ASSEMBLY	
23	062670612	2	ナヘ"ユ357-40X6	SCREW 357X6	
24	112364001	1	ハイ"ユ"ハ"イ"フ"ツ"キ"テ"ネ"シ"	OIL FEEDING PIPE JOINT SCREW	
25	159476000	2	サ"カ"ネ	WASHER	
26	S08951001	1	ビ"ニ"ル"チ"ユ"ー"ブ"ク"ミ	VINYL TUBE ASSEMBLY	
27	112351001	1	ハイ"ユ"ハ"イ"フ"ネ"シ"	OIL FEEDING PIPE SCREW	
28	112348001	2	ハ"ツ"キン	PACKING	
29	155282101	1	ビ"ニ"ル"チ"ユ"ー"ブ"ク"ミ	OIL TUBE ASSEMBLY	
30	112359001	2	ハイ"ユ"ハ"イ"フ"ツ"キ"テ"ネ"シ"	OIL FEEDING PIPE JOINT SCREW	
31	112348001	4	ハ"ツ"キン	PACKING	
32	S08955001	1	オイル"フ"ィ"ル"ター"フ"タ	OIL FILTER CAP	
33	062680812	4	ナヘ"ユ437-40X8	SCREW 437X8	
34	S08956000	1	オイル"フ"ィ"ル"ター	OIL FILTER	
35	S08957001	1	オイルクチ	OIL FEEDING PIPE	
36	081044070	1	O"リ"ン"ク"P44	O RING P44	
37	S08953001	1	ビ"ニ"ル"チ"ユ"ー"ブ"ク"ミ	VINYL TUBE ASSEMBLY	
38	112359001	1	ハイ"ユ"ハ"イ"フ"ツ"キ"テ"ネ"シ"	OIL FEEDING PIPE JOINT SCREW	
39	112348001	2	ハ"ツ"キン	PACKING	
40	S08958001	1	ロツト"オイル"ハ"イ"フ"D"ク"ミ	MAIN OIL PIPE (D) ASSEMBLY	
41	062670612	1	ナヘ"ユ357-40X6	SCREW 357X6	
42	S09316000	1	オイル"フ"ィ"ル"ター"D	OIL FILTER (D)	
43	062680812	4	ナヘ"ユ437-40X8	SCREW 437X8	
44	100645003	4	サ"カ"ネ	WASHER	
45	S09125001	1	チューブ"ガ"イ"ト"	OIL TUBE GUIDE	
46	062780812	1	ナヘ"ユ635-28X8	SCREW 635X8	
48	147363000	1	フ"エ"ルト	FELT	

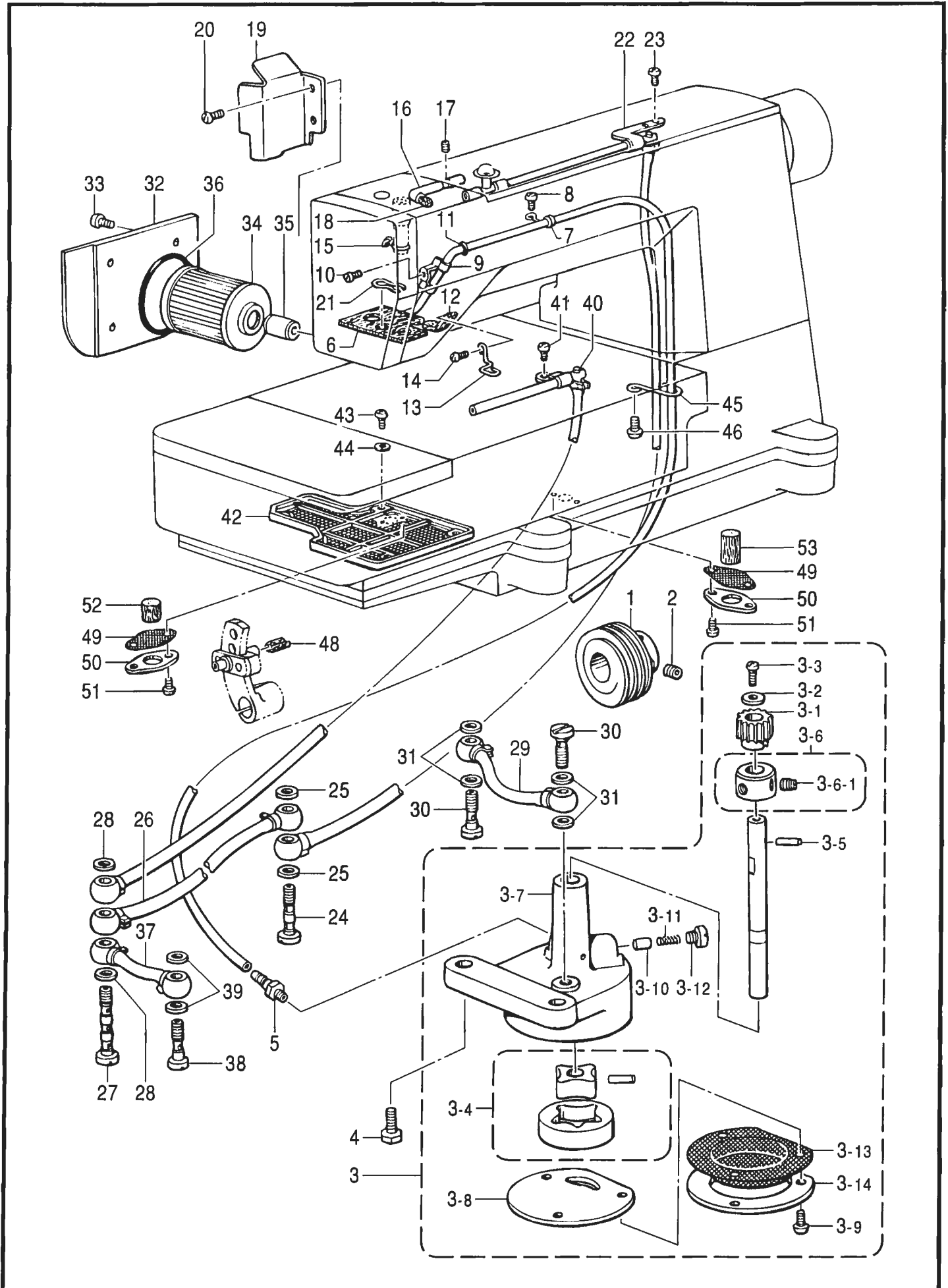

G. 給油潤滑関係/Lubrication

REF NO	CODE	Q'TY	ヒンメイ	NAME OF PARTS	RMKS
49	155294100	2	ロカモウ	OIL FILTER	
50	155295001	2	ロカモウオサイエタ	OIL FILTER FLANGE	
51	062670612	4	ナヘコ357-40X6	SCREW 357X6	
52	151927001	1	クラッチフェルト	CLUTCH FELT	
53	112754001	1	フェルト	FELT	

H. ルーパー関係 / Looper mechanism

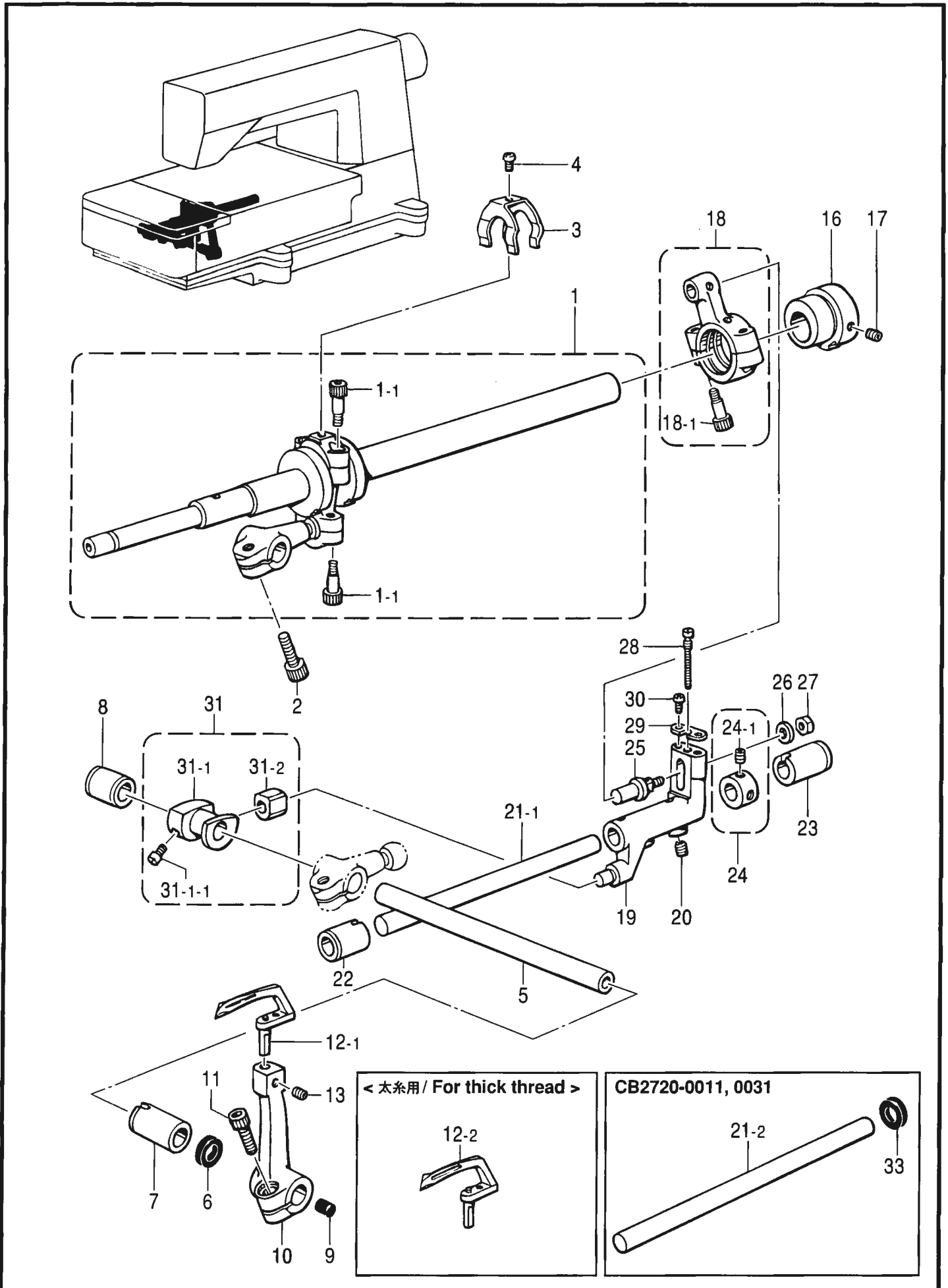

H. ルーバ関係 / Looper mechanism

REF NO	CODE	Q'TY	ヒンメイ	NAME OF PARTS	RMKS
1	S08906001	1	ルーバ ^o クランクシ ^o クミ	LOOPER CRANK SHAFT ASSEMBLY	
1-1	148425001	4	アナホ ^o ルト4.37X14	BOLT 4.37X14	
2	018771432	1	アナホ ^o ルト635-40X14	BOLT 635X14	
3	110704001	1	ウフルーバ ^o ロツト ^o フレト ^o メ	LOOPER CONNECTING ROD STOPPER	
4	062660412	1	ナヘ ^o コ318-40X4	SCREW 318X4	
5	S08910001	1	ルーバ ^o シ ^o ク	LOOPER SHAFT	
6	155539000	1	タ ^o ストシール	DUST SEAL	
7	S08770000	1	シ ^o クメタル	NEEDLE THREAD TAKE-UP SHAFT BUSH (F)	
8	S08911000	1	ルーバ ^o シ ^o クメタルB	LOOPER SHAFT BUSH (B)	
9	140327001	1	ゴ ^o ムセン	OIL CAP	
10	S08912001	1	ルーバ ^o ホルタ ^o	LOOPER HOLDER	
11	018771432	1	アナホ ^o ルト635-40X14	BOLT 635X14	
12-1	S08913001	1	ルーバ ^o (ヒヨウジ ^o ユンヨウ)	LOOPER (FOR STANDARD)	*
12-2	S12683001	1	ルーバ ^o (フトイトヨウ)	LOOPER (FOR THICK THREAD)	*
13	014680422	1	アナトメネジ ^o 4.37クホ ^o ミ	SET SCREW 4.37	
16	S08914001	1	ゼ ^o ンゴ ^o ヘンシンリン	LONGITUDINAL ECCENTRIC CAM	
17	014680622	2	アナトメネジ ^o 4.37クホ ^o ミ	SET SCREW 4.37	
18	146624101	1	ゼ ^o ンゴ ^o ロツト ^o クミ	LONGITUDINAL FEED ROD ASSEMBLY	
18-1	148425001	2	アナホ ^o ルト4.37X14	BOLT 4.37X14	
19	S08915001	1	ゼ ^o ンゴ ^o レハ ^o ー	LONGITUDINAL LEVER	
20	014770622	2	アナトメネジ ^o 6.35クホ ^o ミ	SET SCREW 6.35	
22	S08917000	1	レハ ^o ーシ ^o クメタルL	LONGITUDINAL FEED SHAFT BUSH (L)	
23	S08754000	1	ハリウケBシ ^o クメタルR	KNIFE DRIVING SHAFT BUSH (R)	
24	S03704001	1	セツカ ^o ラー ^o クミ	SET COLLAR ASSEMBLY	
24-1	014770622	2	アナトメネジ ^o 6.35クホ ^o ミ	SET SCREW 6.35	
25	S08918001	1	ゼ ^o ンゴ ^o ロツト ^o ヒ ^o ン	LONGITUDINAL ROD PIN	
26	148847001	1	サ ^o カ ^o ネ	WASHER	
27	110161006	1	ナツト4.76	NUT 4.76	
28	S08919001	1	ヘンシンチヨウセツネジ ^o	ADJUST SCREW	
29	S08920001	1	ヘンシントメイタ	ECCENTRIC WHEEL STOPPER PLATE	
30	062630612	2	ナヘ ^o コ238-56X6	SCREW 238X6	
31	S08921101	1	ゼ ^o ンゴ ^o コマクミ	LONGITUDINAL BLOCK ASSEMBLY	
31-1	S09251001	1	ゼ ^o ンゴ ^o コマネジ ^o ツキ	LONGITUDINAL BLOCK WITH SCREW	
31-1-1	120990001	2	アタマツキトメネジ ^o 4.37	SET SCREW 4.37	
31-2	140313001	1	ゼ ^o ンゴ ^o レハ ^o ーカクゴ ^o マ	LONGITUDINAL FEED LEVER SLIDE BLOCK	
< FOR CB2720-0021, 0071 >					
21-1	S08916001	1	ゼ ^o ンゴ ^o レハ ^o ーシ ^o ク	LONGITUDINAL FEED SHAFT	
< FOR CB2720-0011, 0031 >					
21-2	S11588001	1	ゼ ^o ンゴ ^o レハ ^o ーシ ^o ク	LONGITUDINAL FEED SHAFT	
33	S11589000	1	タ ^o ストシール	DUST SEAL	

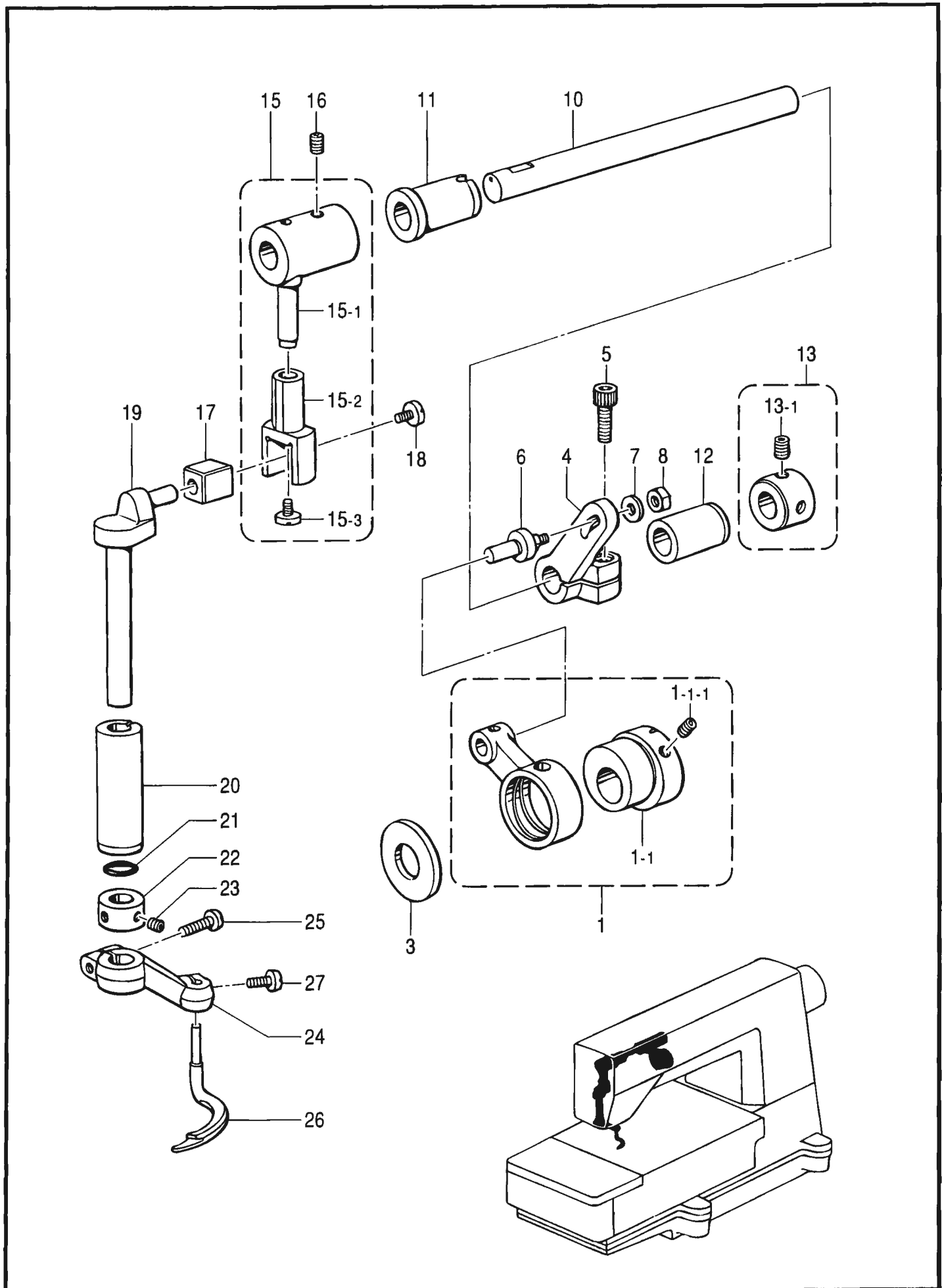

J. スプレダ関係 (CB2720)/Spreader mechanism (CB2720)

REF.NO	CODE	Q'TY	ヒンメイ	NAME OF PARTS	RMKS
1	S08923101	1	スプレタ"ヘンシンリンクミ	SPREADER ECCENTRIC WHEEL ASSEMBLY	
1-1	S10656001	1	ヘンシンリンクネジ"ツキ	WITH SCREW ECCENTRIC WHEEL	
1-1-1	014680622	2	アナトメネジ"4.37クホ"ミ	SET SCREW 4.37	
3	101482001	1	レンカンシキリノイタ	CONNECTING ROD PARTITION PLATE	
4	S08926101	1	スプレタ"レハ"ーR	SPREADER LEVER (R)	
5	018771432	1	アナホル"ルト635-40X14	BOLT 635X144	
6	S13809001	1	スプレタ"ロツト"ヒ"ン	SPREADER ROD PIN	
7	148847001	1	サ"カ"ネ	WASHER	
8	110161006	1	ナツト4.76	NUT 4.76	
10	S08927001	1	スプレタ"シ"ク	SPREADER SHAFT	
11	148196000	1	ウウメスサ"ウウテ"メタルL	SPREADER SHAFT BUSH (L)	
12	148197000	1	ウウメスサ"ウウテ"メタルR	SPREADER SHAFT BUSH (R)	
13	S03421001	1	セツトカラ"ク"ミ	SET COLLAR ASSEMBLY	
13-1	014770622	2	アナトメネジ"6.35クホ"ミ	SET SCREW 6.35	
15	S08928001	1	スプレタ"レハ"ーLク"ミ	SPREADER LEVER (L) ASSEMBLY	
15-1	※ S08929001	1	スプレタ"レハ"ーL	SPREADER LEVER (L)	
15-2	※ S08930001	1	スプレタ"フタマタ	SPREADER FORK	
15-3	148834001	1	シメネジ"3.57	SCREW 3.57	
16	014770622	2	アナトメネジ"6.35クホ"ミ	SET SCREW 6.35	
17	146547000	1	オクリタ"イカクコ"マ	FEED BAR SLIDE BLOCK	
18	148834001	1	シメネジ"3.57	SCREW 3.57	
19	S08931001	1	スプレタ"タテシ"ク	SPREADER VERTICAL SHAFT	
20	S08932000	1	スプレタ"タテシ"クメタル	SPREADER VERTICAL SHAFT BUSH	
21	081007670	1	Oリング"PW7	O RING PW7	
22	110197001	1	セツトカラ"ー	SET COLLAR	
23	014680422	2	アナトメネジ"4.37クホ"ミ	SET SCREW 4.37	
24	S08933001	1	スプレタ"ホルタ"	SPREADER HOLDER	
25	062681412	1	ナヘ"コ437-40X14	SCREW 437X14	
26	S08934001	1	スプレタ"	SPREADER	
27	062681012	1	ナヘ"コ437-40X10	SCREW 437X10	

※印は共合せ加工がされていますので組で御注文下さい。

Parts marked with an asterisk ※ are manufactured in assemblies. Be sure to order by the assembly code.

K1 . 糸調子関係 (CB2710) / Thread tension (CB2710)

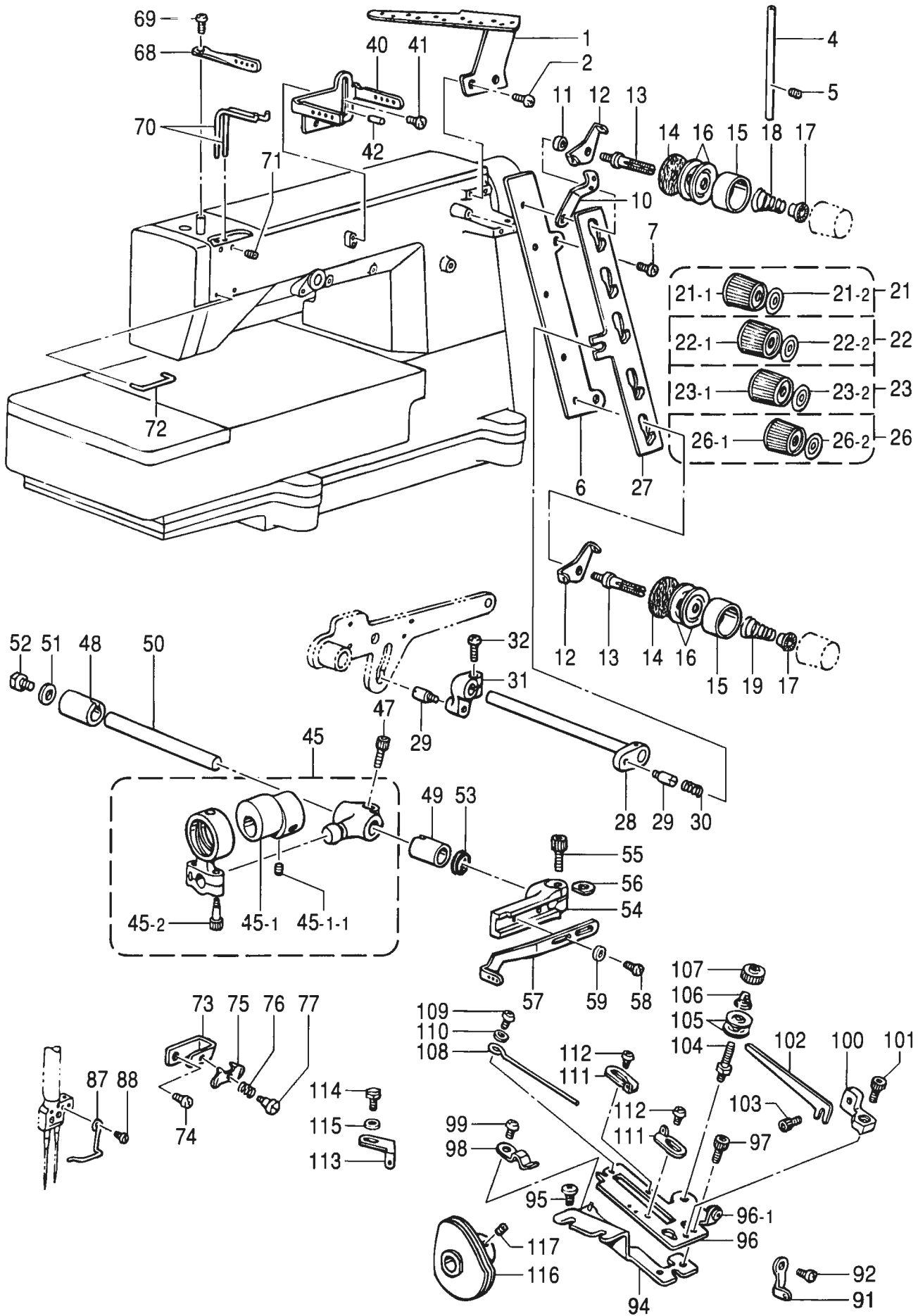

K1. 糸調子関係 (CB2710)/Thread tension (CB2710)

REF NO	CODE	Q'TY	ヒンメイ	NAME OF PARTS	RMKS
1	S08961101	1	シユイトアンナイ	MAIN THREAD GUIDE	
2	062680812	2	ナヘ"コ437-40X8	SCREW 437X8	
4	150645009	1	イトアンナイハ"イフ"L	THREAD GUIDE PIPE (L)	
5	014680422	1	アナトメネジ"4.37クホ"ミ	SET SCREW 4.37	
6	S08962109	1	イトチヨウシタ"イ	TENSION BASE	
7	062681012	2	ナヘ"コ437-40X10	SCREW 437X10	
10	S08963001	4	イトチヨウシタ"イトアンナイ	TENSION BASE THREAD GUIDE	
11	S08964001	4	カンザ"	SPACER	
12	110813001	4	ハリイトアンナイ	NEEDLE THREAD GUIDE	
13	159574101	4	イトチヨウシホ"ウ	TENSION STUD	
14	110832009	4	イトチヨウシサラフエルト	TENSION DISC FELT	
15	144103009	4	イトチヨウシサラオサエ	TENSION DISC WASHER	
16	145446001	8	イトチヨウシサラ	TENSION DISC	
17	144105000	4	チヨウシハ"ネウエサ"カ"ネ	SPRING WASHER	
18	144104001	3	ハリイトチヨウシハ"ネ	NEEDLE THREAD TENSION SPRING	
19	144110001	1	シタルーハ"イトチヨウシハ"ネ	TENSION SPRING	
21	S19869003	1	イトチヨウシナツクミ(アカ)	TENSION NUT ASSEMBLY (RED)	
21-1	149566009	1	イトチヨウシナツ	TENSION NUT	
21-2	155697003	1	キヨウシ"ヤクハ"ン	TENSION INDICATING PLATE	
22	S19869004	1	イトチヨウシナツクミ(キイ)	TENSION NUT ASSEMBLY (YELLOW)	
22-1	149566009	1	イトチヨウシナツ	TENSION NUT	
22-2	155697004	1	キヨウシ"ヤクハ"ン	TENSION INDICATING PLATE	
23	S19869002	1	イトチヨウシナツクミ (ミト"リ)	TENSION NUT ASSEMBLY (GREEN)	
23-1	149566009	1	イトチヨウシナツ	TENSION NUT	
23-2	155697002	1	キヨウシ"ヤクハ"ン	TENSION INDICATING PLATE	
26	S19869001	1	イトチヨウシナツクミ (ミス"イロ)	TENSION NUT ASSEMBLY (LIGHT BLUE)	
26-1	149566009	1	イトチヨウシナツ	TENSION NUT	
26-2	155697001	1	キヨウシ"ヤクハ"ン	TENSION INDICATING PLATE	
27	S08965009	1	イトユルメイタ	TENSION RELEASE PLATE	
28	S08966001	1	イトユルメジ"ク	TENSION RELEASE SHAFT	
29	S08967001	2	シメネジ"4.76	SCREW 4.76	
30	118718001	1	オサエホ"ウダ"キオシハ"ネ	COIL SPRING	
31	S08968001	1	イトユルメウテ"	TENSION RELEASE ARM	
32	062681212	1	ナヘ"コ437-40X12	SCREW 437X12	
40	S08969101	1	チユウカンイトアンナイ	THREAD GUIDE	
41	060680712	1	ハ"イント"437-40X7	SCREW 437X7	
42	143602001	1	ミゾ"ツキヒ"ン	DOWEL PIN	
45	S08971101	1	ハリイトクリヘンシンリンクミ	NEEDLE THREAD TAKE-UP ECCENTRIC ASSEMBLY	
45-1	S10657001	1	イトクリヘンシンリンクミ"ツキ	WITH SCREW TAKE-UP ECCENTRIC WHEEL	
45-1-1	014770622	2	アナトメネジ"6.35クホ"ミ	SET SCREW 6.35	
45-2	148425001	2	アナホ"ルト4.37X14	BOLT 4.37X14	
47	018771432	1	アナホ"ルト635-40X14	BOLT 635X14	
48	155220000	1	ホジ"ヨアツメタルR	AUTO PRESSER ARM BUSH (R)	
49	S08770000	1	ジ"クメタル	NEEDLE THREAD TAKE-UP SHAFT BUSH (F)	
50	S08976001	1	ハリイトクリジ"ク	NEEDLE THREAD TAKE-UP SHAFT	
51	S00356001	1	サ"カ"ネ	WASHER	
52	S00383001	1	ホ"ルト5.56X8	BOLT 5.56X8	
53	155539000	1	ダ"ストシール	DUST SEAL	
54	S08977001	1	ハリイトクリレハ"ー	NEEDLE THREAD TAKE-UP LEVER	
55	018771432	1	アナホ"ルト635-40X14	BOLT 635X14	
56	155162001	1	スヘ"ーサ	SPACER	
57	S08978001	1	ハリイトクリ	NEEDLE THREAD TAKE-UP	
58	062681012	2	ナヘ"コ437-40X10	SCREW 437X10	
59	100645003	2	サ"カ"ネ	WASHER	
68	S08981001	1	ハリホ"ウチンヒ"ン	NEEDLE BAR TAKE-UP	
69	062670612	1	ナヘ"コ357-40X6	SCREW 357X6	
70	S08982001	2	ハリイトウケ	NEEDLE THREAD GUIDE	
71	014680422	2	アナトメネジ"4.37クホ"ミ	SET SCREW 4.37	
72	S08983001	1	アームハリイトウケ	ARM NEEDLE THREAD GUIDE	
73	S08984001	1	サブ"テンシヨント"ダ"イ	SUB TENSION BASE	

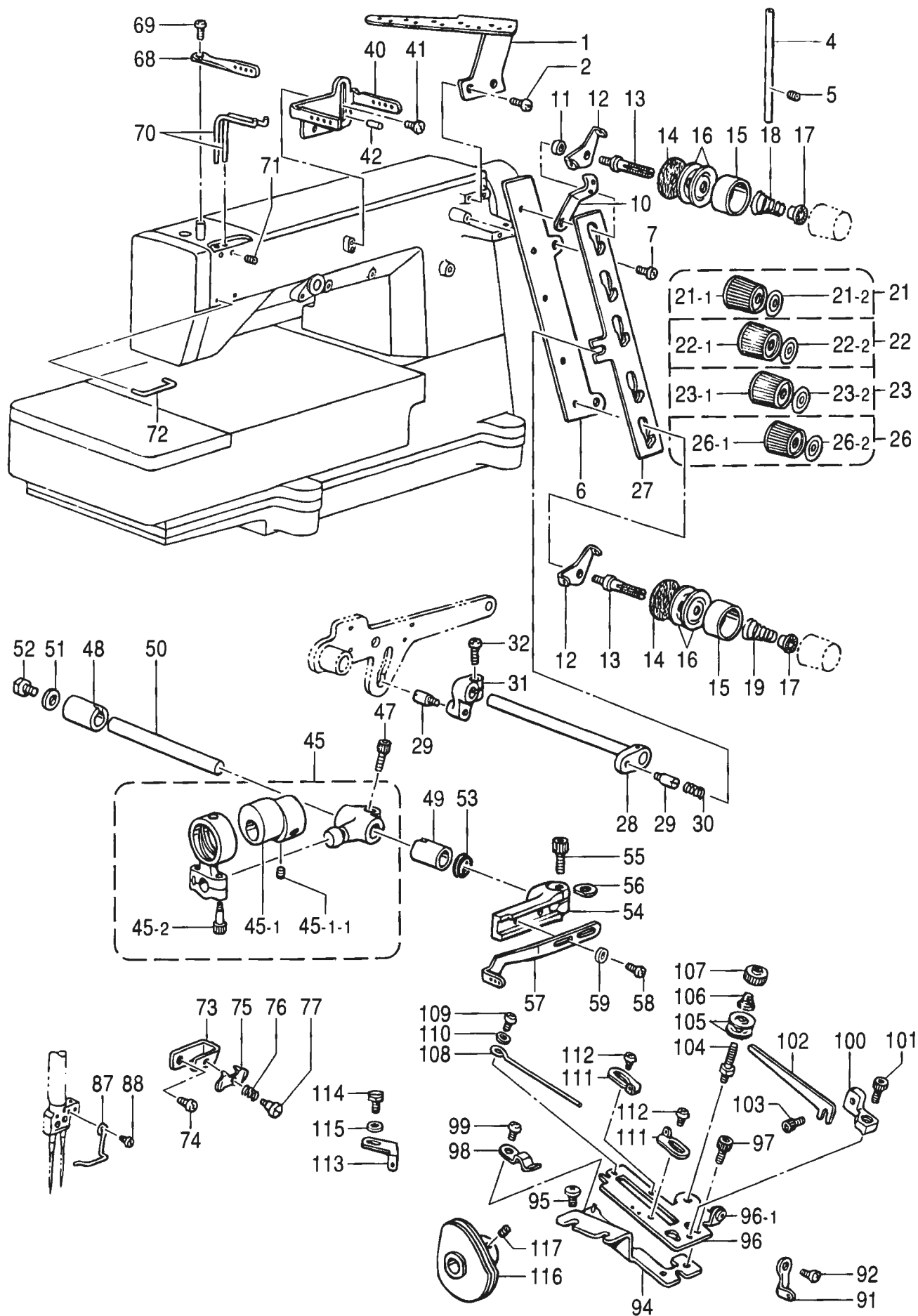

K1. 糸調子関係 (CB2710)/Thread tension (CB2710)

REF NO	CODE	Q'TY	ヒンメイ	NAME OF PARTS	RMKS
74	062680812	1	ナヘ"コ437-40X8	SCREW 437X8	
75	112300001	1	ハリトオサエ	NEEDLE THREAD CLAMP	
76	112299001	1	ハリトアンナイオシハ"ネ	COIL SPRING	
77	112301001	1	ダ"ンネシ"3.18	STUD SCREW 3.18	
87	S08989001	1	ハリト"メイトアンナイ	NEEDLE CLAMP THREAD GUIDE	
88	062630412	1	ナヘ"コ238-56X4	SCREW 238X4	
91	S08970001	1	イトアンナイS	THREAD GUIDE (S)	
92	062680612	1	ナヘ"コ437-40X6	SCREW 437X6	
94	S18530001	1	テンビ"ント"ダ"イDクミ	LOOPER THREAD TAKE-UP BASE (D) ASSEMBLY	
95	060680712	2	ハ"イント"437-40X7	SCREW 437X7	
96	S18532001	1	テンビ"ント"ダ"イUクミ	LOOPER THREAD TAKE-UP BASE (U) ASSEMBLY	
96-1	146924000	1	スレツト"フ"ツシユ	THREAD BUSH	
97	018680822	2	アナボ"ルト4.37X8	BOLT 4.37X8	
98	S18534001	1	ト"ダ"イオサエハ"ネ	SPRING	
99	062670512	1	ナヘ"コ357-40X5	SCREW 357X5	
100	S18535001	1	イトオサエト"ダ"イ	THREAD PRESSER BASE	
101	154965001	1	アナボ"ルト3.57X8	BOLT 3.57X8	
102	S08992001	1	テンビ"ンイトオサエ	LOOPER TAKE-UP PRESSER	
103	154965001	1	アナボ"ルト3.57X8	BOLT 3.57X8	
104	S08987001	1	イトチヨウシホ"ウ	THREAD TENSION CONTROL STUD	
105	144504001	2	イトアンナイサラ	THREAD GUIDE DISC	
106	144505000	1	イトアンナイハ"ネ	THREAD GUIDE SPRING	
107	15551C001	1	イトチヨウシナツト	TENSION NUT	
108	S08993101	1	テンビ"ンイトウケ	TAKE-UP THREAD GUIDE	
109	062670512	1	ナヘ"コ357-40X5	SCREW 357X5	
110	105161004	1	サ"カ"ネ	WASHER	
111	S08994001	2	テンビ"ンイトアンナイ	THREAD GUIDE	
112	060660416	2	ハ"イント"318-40X4	SCREW 318X4	
113	155313001	1	ウフル-ハ"イトアンナイ	LOOPER THREAD GUIDE	
114	144075001	1	ボ"ルト3.57	BOLT 3.57	
115	105161004	1	サ"カ"ネ	WASHER	
116	S08995001	1	シタイトテンビ"ンクミ	LOOPER THRED TAKE-UP ASSEMBLY	
117	014680422	2	アナトメネシ"4.37クボ"ミ	SET SCREW 4.37	

K2 . 糸調子関係 (CB2720) / Thread tension (CB2720)

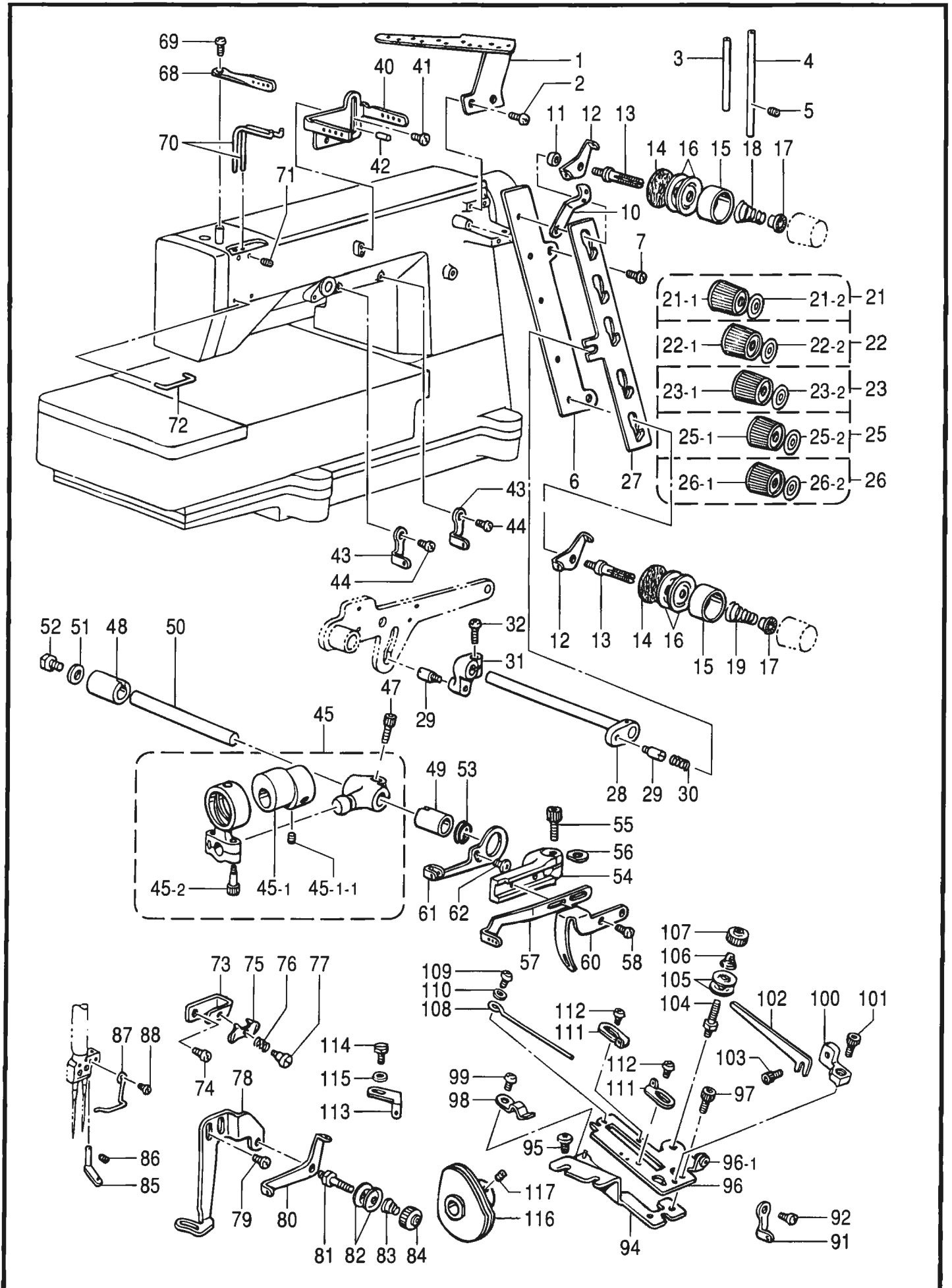

K2. 糸調子関係 (CB2720)/Thread tension (CB2720)

REF NO	CODE	QTY	ヒンメイ	NAME OF PARTS	RMKS
1	S08961101	1	シユイトアンナイ	MAIN THREAD GUIDE	
2	062680812	2	ナヘ"コ437-40X8	SCREW 437X8	
3	150644009	1	イトアンナイパイフ" S	THREAD GUIDE PIPE (S)	
4	150645009	1	イトアンナイパイフ" L	THREAD GUIDE PIPE (L)	
5	014680422	2	アナトメネジ"4.37クホ"ミ	SET SCREW 4.37	
6	S08962109	1	イトチヨウシダ"イ	TENSION BASE	
7	062681012	2	ナヘ"コ437-40X10	SCREW 437X10	
10	S08963001	5	イトチヨウシダ"イトアンナイ	TENSION BASE THREAD GUIDE	
11	S08964001	5	カンザ"	SPACER	
12	110813001	5	ハリイトアンナイ	NEEDLE THREAD GUIDE	
13	159574101	5	イトチヨウシホ"ウ	TENSION STUD	
14	110832009	5	イトチヨウシサラフエルト	TENSION DISC FELT	
15	144103009	5	イトチヨウシサラオサエ	TENSION DISC WASHER	
16	145446001	10	イトチヨウシサラ	TENSION DISC	
17	144105000	5	チヨウシハ"ネウエサ"カ"ネ	SPRING WASHER	
18	144104001	3	ハリイトチヨウシハ"ネ	NEEDLE THREAD TENSION SPRING	
19	144110001	2	シタル-ハ"イトチヨウシハ"ネ	TENSION SPRING	
21	S19869003	1	イトチヨウシナツクミ(アカ)	TENSION NUT ASSEMBLY (RED)	
21-1	149566009	1	イトチヨウシナツクミ	TENSION NUT	
21-2	155697003	1	キヨウシ"ヤクハ"ン	TENSION INDICATING PLATE	
22	S19869004	1	イトチヨウシナツクミ(キイ)	TENSION NUT ASSEMBLY (YELLOW)	
22-1	149566009	1	イトチヨウシナツクミ	TENSION NUT	
22-2	155697004	1	キヨウシ"ヤクハ"ン	TENSION INDICATING PLATE	
23	S19869002	1	イトチヨウシナツクミ (ミト"リ)	TENSION NUT ASSEMBLY (GREEN)	
23-1	149566009	1	イトチヨウシナツクミ	TENSION NUT	
23-2	155697002	1	キヨウシ"ヤクハ"ン	TENSION INDICATING PLATE	
25	S19869003	1	イトチヨウシナツクミ(アカ)	TENSION NUT ASSEMBLY (RED)	
25-1	149566009	1	イトチヨウシナツクミ	TENSION NUT	
25-2	155697003	1	キヨウシ"ヤクハ"ン	TENSION INDICATING PLATE	
26	S19869001	1	イトチヨウシナツクミ (ミズ"イロ)	TENSION NUT ASSEMBLY (LIGHT BLUE)	
26-1	149566009	1	イトチヨウシナツクミ	TENSION NUT	
26-2	155697001	1	キヨウシ"ヤクハ"ン	TENSION INDICATING PLATE	
27	S08965009	1	イトユルメイタ	TENSION RELEASE PLATE	
28	S08966001	1	イトユルメシ"ク	TENSION RELEASE SHAFT	
29	S08967001	2	シメネジ"4.76	SCREW 4.76	
30	118718001	1	オサエホ"ウタ"キオシハ"ネ	COIL SPRING	
31	S08968001	1	イトユルメウテ"	TENSION RELEASE ARM	
32	062681212	1	ナヘ"コ437-40X12	SCREW 437X12	
40	S08969101	1	チユウカンイトアンナイ	THREAD GUIDE	
41	060680712	1	ハ"イント"437-40X7	SCREW 437X7	
42	143602001	1	ミゾ"ツキヒ"ン	DOWEL PIN	
43	S08970001	2	イトアンナイS	THREAD GUIDE (S)	
44	062680612	2	ナヘ"コ437-40X6	SCREW 437X6	
45	S08971101	1	ハリイトクリヘンシンリンクミ	NEEDLE THREAD TAKE-UP ECCENTRIC ASSEMBLY	
45-1	S10657001	1	イトクリヘンシンリンネジ"ツキ	WITH SCREW TAKE-UP ECCENTRIC WHEEL	
45-1-1	014770622	2	アナトメネジ"6.35クホ"ミ	SET SCREW 6.35	
45-2	148425001	2	アナホ"ルト4.37X14	BOLT 4.37X14	
47	018771432	1	アナホ"ルト635-40X14	BOLT 635X14	
48	155220000	1	ホシ"ヨアツメタルR	AUTO PRESSER ARM BUSH (R)	
49	S08770000	1	シ"クメタル	NEEDLE THREAD TAKE-UP SHAFT BUSH (F)	
50	S08976001	1	ハリイトクリシ"ク	NEEDLE THREAD TAKE-UP SHAFT	
51	S00356001	1	サ"カ"ネ	WASHER	
52	S00383001	1	ホ"ルト5.56X8	BOLT 5.56X8	
53	155539000	1	タ"ストシール	DUST SEAL	
54	S08977001	1	ハリイトクリルハ"ー	NEEDLE THREAD TAKE-UP LEVER	
55	018771432	1	アナホ"ルト635-40X14	BOLT 635X14	
56	155162001	1	スヘ"ーサ	SPACER	
57	S08978001	1	ハリイトクリ	NEEDLE THREAD TAKE-UP	
58	062681012	2	ナヘ"コ437-40X10	SCREW 437X10	
60	S08979001	1	カザ"リイトクリ	COVERING THREAD TAKE-UP	

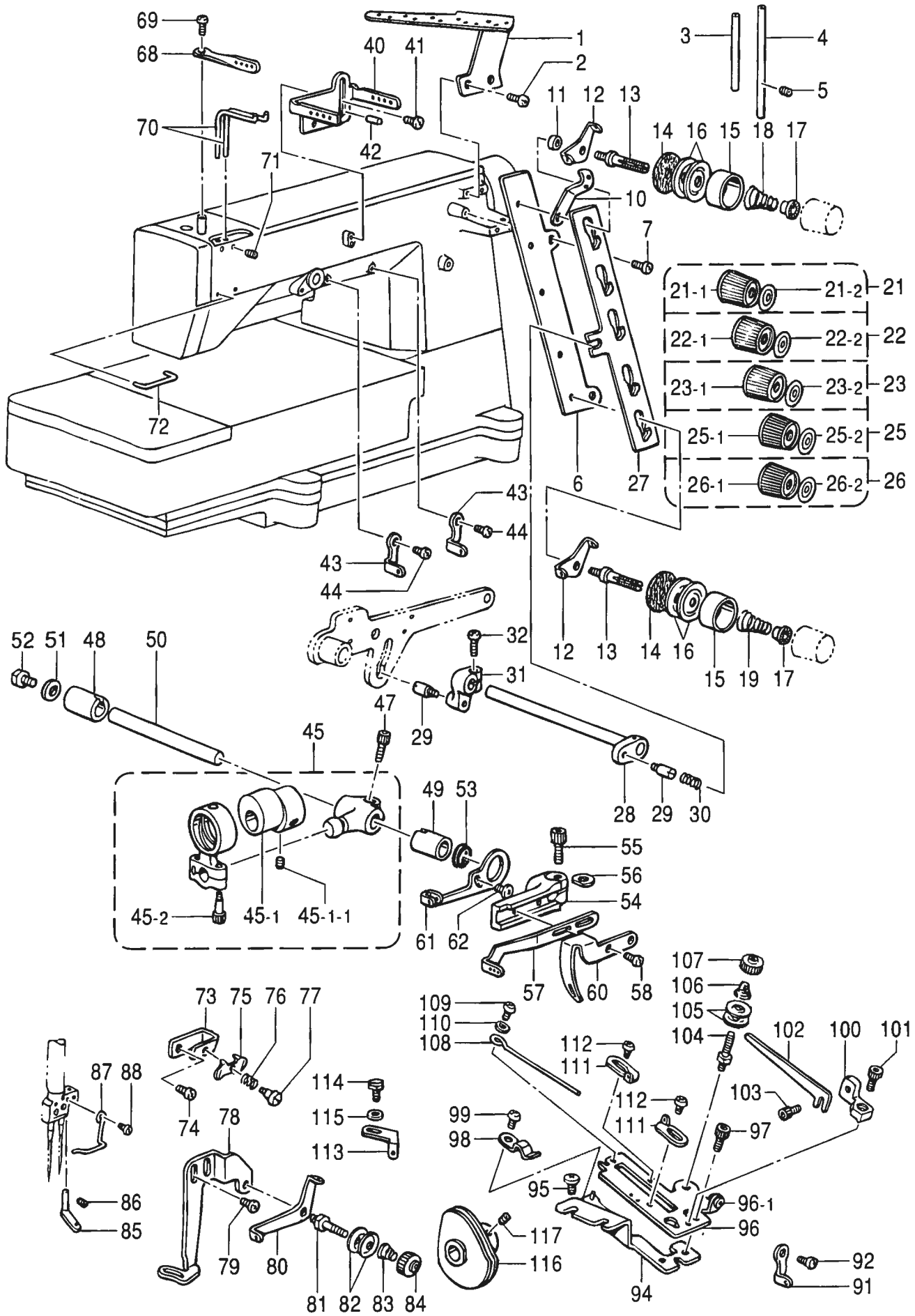

K2. 糸調子関係 (CB2720)/Thread tension (CB2720)

REF NO	CODE	Q'TY	ヒンメイ	NAME OF PARTS	RMKS
61	S08980001	1	カザ"ライトアンナイR	COVERING THREAD GUIDE (R)	
62	060680712	1	ハ"イント"437-40X7	SCREW 4.37X7	
68	S08981001	1	ハリホ"ウテンピン	NEEDLE BAR TAKE-UP	
69	062670612	1	ナヘ"コ357-40X6	SCREW 357X6	
70	S08982001	2	ハリイトウケ	NEEDLE THREAD GUIDE	
71	014680422	2	アナトメネシ"4.37クホ"ミ	SET SCREW 4.37	
72	S08983001	1	アームハリイトウケ	ARM NEEDLE THREAD GUIDE	
73	S08984001	1	サブ"テンション"タ"イ	SUB TENSION BASE	
74	062680812	1	ナヘ"コ437-40X8	SCREW 437X8	
75	112300001	1	ハリイトオサエ	NEEDLE THREAD CLAMP	
76	112299001	1	ハリイトアンナイオシハ"ネ	COIL SPRING	
77	112301001	1	タ"ンネシ"3.18	STUD SCREW 3.18	
78	S08985001	1	カザ"ライトアンナイL	COVERING THREAD GUIDE (L)	
79	060680712	2	ハ"イント"437-40X7	SCREW 437X7	
80	S08986001	1	カザ"ライトアンナイ	COVERING THREAD GUIDE	
81	S08987001	1	イトチヨウシホ"ウ	THREAD TENSION CONTROL STUD	
82	144504001	2	イトアンナイサラ	THREAD GUIDE DISC	
83	144505000	1	イトアンナイハ"ネ	THREAD GUIDE SPRING	
84	155510001	1	イトチヨウシナツト	TENSION NUT	
85	S08988001	1	ハリト"メカザ"ライトアンナイ	NEEDLE CLAMP COVERING THREAD GUIDE	
86	146427001	1	アナトメネシ"3.18クホ"ミ	SET SCREW 3.18	
87	S08989001	1	ハリト"メイトアンナイ	NEEDLE CLAMP THREAD GUIDE	
88	062630412	1	ナヘ"コ238-56X4	SCREW 238X4	
91	S08970001	1	イトアンナイS	THREAD GUIDE (S)	
92	062680612	1	ナヘ"コ437-40X6	SCREW 437X6	
94	S18530001	1	デンビ"ント"タ"イDクミ	LOOPER THREAD TAKE-UP BASE (D) ASSEMBLY	
95	060680712	2	ハ"イント"437-40X7	SCREW 437X7	
96	S18532001	1	デンビ"ント"タ"イUクミ	LOOPER THREAD TAKE-UP BASE (U) ASSEMBLY	
96-1	146924000	1	スレット"フ"ツシユ	THREAD BUSH	
97	018680822	2	アナホ"ルト4.37X8	BOLT 4.37X8	
98	S18534001	1	ト"タ"イオサエハ"ネ	SPRING	
99	062670512	1	ナヘ"コ357-40X5	SCREW 357X5	
100	S18535001	1	イトオサエト"タ"イ	THREAD PRESSER BASE	
101	154965001	1	アナホ"ルト3.57X8	BOLT 3.57X8	
102	S08992001	1	デンビ"ンイトオサエ	LOOPER TAKE-UP PRESSER	
103	154965001	1	アナホ"ルト3.57X8	BOLT 3.57X8	
104	S08987001	1	イトチヨウシホ"ウ	THREAD TENSION CONTROL STUD	
105	144504001	2	イトアンナイサラ	THREAD GUIDE DISC	
106	144505000	1	イトアンナイハ"ネ	THREAD GUIDE SPRING	
107	155510001	1	イトチヨウシナツト	TENSION NUT	
108	S08993101	1	デンビ"ンイトウケ	TAKE-UP THREAD GUIDE	
109	062670512	1	ナヘ"コ357-40X5	SCREW 357X5	
110	105161004	1	サ"カ"ネ	WASHER	
111	S08994001	2	デンビ"ンイトアンナイ	THREAD GUIDE	
112	060660416	2	ハ"イント"318-40X4	SCREW 318X4	
113	155313001	1	ウフルーハ"イトアンナイ	LOOPER THREAD GUIDE	
114	144075001	1	ホ"ルト3.57	BOLT 3.57	
115	105161004	1	サ"カ"ネ	WASHER	
116	S08995001	1	シタイトデンビ"ンクミ	LOOPER THREAD TAKE-UP ASSEMBLY	
117	014680422	2	アナトメネシ"4.37クホ"ミ	SET SCREW 4.37	

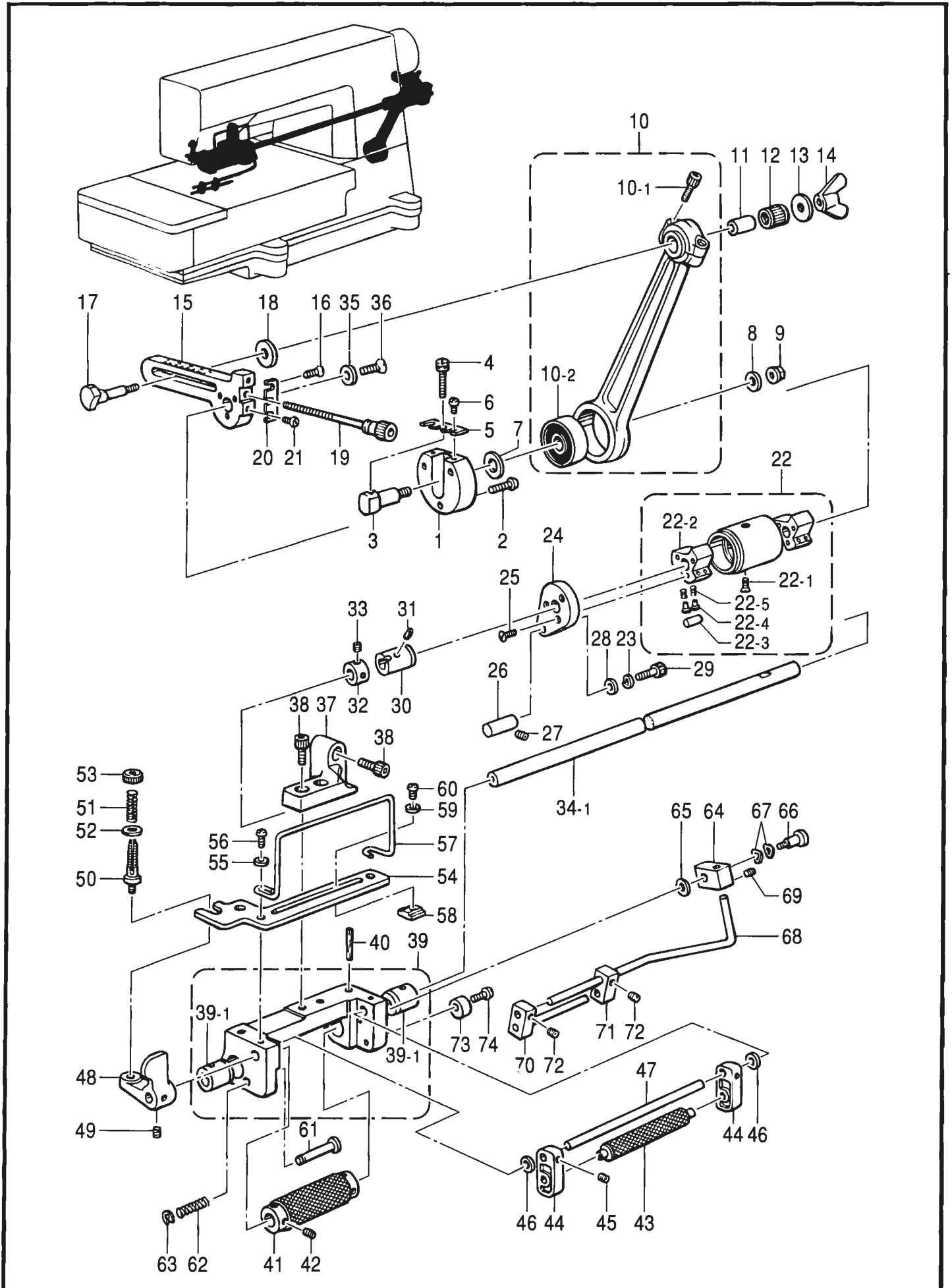

L. 上ゴム送り関係 (CB2710, 2720 0071)/Upper rubber feed mechanism (CB2710, 2720-0071)

REF NO.	CODE	Q'TY	ヒンメイ	NAME OF PARTS	RMKS
< FOR CB2710, CB2720-0071 >					
1	S09023101	1	ハンシント"タイ	ECCENTRIC WHEEL BASE	
2	062681412	3	ナヘ"コ437-40X14	SCREW 437X14	
3	S09024001	1	ハンシンチヨウセツシ"ク	ECCENTRIC WHEEL ADJUST SHAFT	
4	S09025001	1	ハンシンチヨウセツツネシ"	ECCENTRIC WHEEL ADJUST SCREW	
5	S09026001	1	ハンシントメイタ	ECCENTRIC WHEEL STOPPER PLATE	
6	062670612	2	ナヘ"コ357-40X6	SCREW 357X6	
7	S09027001	1	ヒラサ"ガ"ネシヨウ10	PLAIN WASHER 10	
8	107453001	1	サ"ガ"ネ	WASHER	
9	110778002	1	サ"ツキナツト5.56	NUT 5.56	
10	S09028001	1	ウワゴ"ムオクリロツトタイクミ	RUBBER FEED ROD BODY ASSEMBLY	
10-1	148425001	2	アナホ"ルト4.37X14	BOLT 4.37X14	
10-2	076300800	1	タマシ"クウケ6300ZZ	BALL BEARING 6300ZZ	
11	S09036001	1	ゴ"ムオクリフ"シユ	RUBBER FEED BUSH	
12	S09032001	1	ニート"ルジ"クウケ	NEEDLE BEARING	
13	116662004	1	サ"ガ"ネ	WASHER	
14	148007001	1	チヨウナツト4.76	NUT 4.76	
15	S09033001	1	ゴ"ムオクリルハ"ー	RUBBER FEED LEVER	
16	106128004	3	サラネシ"3.57	SCREW 3.57	
17	S09034001	1	ゴ"ムオクリロツト"シ"ク	RUBBER FEED ROD SHAFT	
18	151090001	1	スラストサ"ガ"ネ	THRUST WASHER	
19	S09035001	1	チヨウセツツネシ"	ADJUST SCREW	
20	S09026001	1	ハンシントメイタ	ECCENTRIC WHEEL STOPPER PLATE	
21	062670612	2	ナヘ"コ357-40X6	SCREW 357X6	
22	S09037001	1	クラツチクミ	CLUTCH ASSEMBLY	
22-1	102843004	1	サラネシ"3.57	SCREW 3.57	
22-2	S09039001	2	クラツチツメ	CLUTCH CLAW	
22-3	150604101	6	コロ	ROLLER	
22-4	150605001	12	クラツチヒ"ン	CLUTCH PIN	
22-5	150606001	12	クラツチハ"ネ	CLUTCH SPRING	
23	028060242	1	ハ"ネサ"ガ"ネ2-6	SPRING WASHER 2-6	
24	S09040001	1	クラツチフタ	CLUTCH CAP	
25	106128004	3	サラネシ"3.57	SCREW 3.57	
26	S09041001	1	ストップヒ"ン	STOPPER PIN	
27	014780622	1	アナトメネシ"6.35クホ"ミ	SET SCREW 6.35	
28	118735002	1	サ"ガ"ネ	WASHER	
29	018061422	1	アナホ"ルト6X14	BOLT 6X14	
30	S09042000	1	ゴ"ムオクリメタルR	RUBBER FEED SHAFT BUSH (R)	
31	S09043000	1	フェルト	FELT	
32	110197001	1	セツトカラ"ー	SET COLLAR	
33	153675001	2	アナトメネシ"4.37	SET SCREW 4.37	
34-1	S09044001	1	ウワゴ"ムオクリシ"ク	RUBBER FEED SHAFT	
35	S09045001	1	サ"ガ"ネ	WASHER	
36	S01698001	1	サラネシ"5.95X12	SCREW 5.95X12	
37	S09046001	1	チヨウセツト"タイ	ADJUST BASE	
38	018061222	4	アナホ"ルト6X12	BOLT 6X12	
39	S09047001	1	ウワゴ"ムオクリダ"イクミ	RUBBER FEED BASE ASSEMBLY	
39-1	S09049000	2	ゴ"ムオクリメタルL	RUBBER FEED SHAFT BUSH (L)	
40	147691000	2	フェルト	FELT	
41	S09050001	1	ゴ"ムオクリローラ	RUBBER FEED ROLLER	
42	148294001	4	アナトメネシ"3.57クホ"ミ	SET SCREW 3.57	
43	S09051001	1	テンションローラ	TENSION ROLLER	
44	S09052001	2	テンションローラササエ	TENSION ROLLER SUPPORT	
45	014680422	2	アナトメネシ"4.37クホ"ミ	SET SCREW 4.37	
46	109763002	2	サ"ガ"ネ	WASHER	
47	S09053001	1	テンションローラシ"ク	TENSION ROLLER SHAFT	
48	S09054001	1	ローラアケ"テコ	ROLLER LIFTER LEVER	
49	014680422	2	アナトメネシ"4.37クホ"ミ	SET SCREW 4.37	
50	110820101	1	イトチヨウシホ"ウ	TENSION STUD	
51	S09055001	1	ローラアツハ"ネ	SPRING	
52	025770232	1	ヒラサ"ガ"ネチユウ6.35	PLAIN WASHER 6.35	

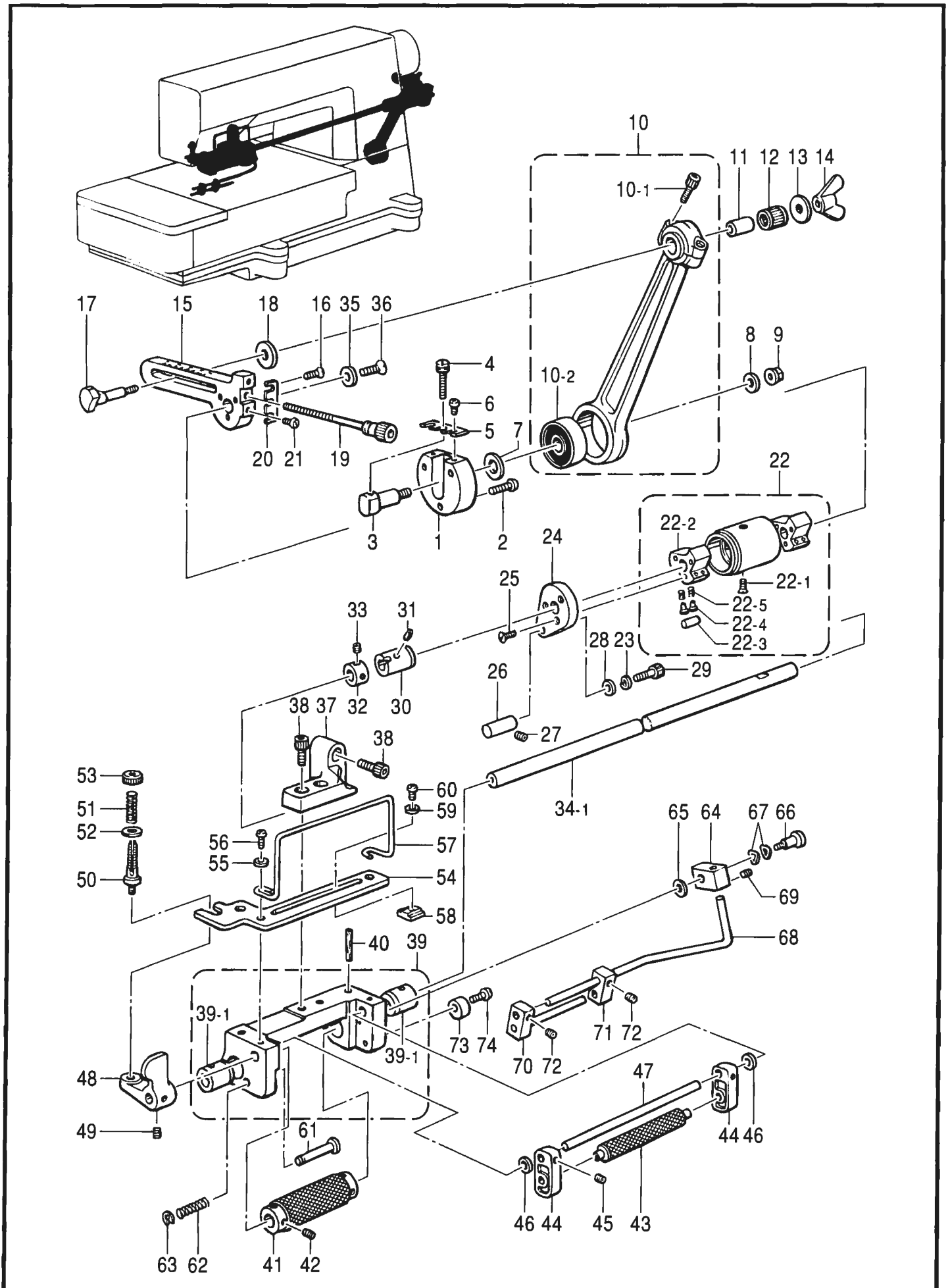

L. 上ゴム送り関係 (CB2710, 2720 0071)/Upper rubber feed mechanism (CB2710, 2720-0071)

REF.NO	CODE	Q'TY	ヒンメイ	NAME OF PARTS	RMKS
53	100136001	1	イトチヨウシナツト	TENSION NUT	
54	S09056001	1	ゴムガイドイタ	RUBBER GUIDE PLATE	
55	148847001	2	サカネ	WASHER	
56	062681012	2	ナヘコ437-40X10	SCREW 437X10	
57	S09057001	1	ゴムガイドM	RUBBER GUIDE (M)	
58	150631001	2	テープアンナイ	TAPE GUIDE	
59	025630232	2	ヒラサカネチユウ2.38	PLAIN WASHER 2.38	
60	060630412	2	ハイント238-56X4	SCREW 238X4	
61	S09058001	1	ローラアケホウ	ROLLER LIFTER BAR	
62	S09059001	1	ローラアケハネ	SPRING	
63	048030342	1	トメフE3	STOP RING E3	
64	S09060001	1	ゴムガイドササエ	RUBBER GUIDE SUPPORT	
65	148847001	1	サカネ	WASHER	
66	141598001	1	タネネジ4.76	STUD SCREW 4.76	
67	103810002	2	ナミカタハネサカネ	SPRING WASHER	
68	S09061001	1	ゴムガイドD	RUBBER GUIDE (D)	
69	014680422	2	アタメネジ4.37クホミ	SET SCREW 4.37	
70	S09062001	1	ゴムガイドササエDクミ	RUBBER GUIDE SUPPORT (D) ASSEMBLY	
71	S09065001	1	ゴムガイドササエ	RUBBER GUIDE SUPPORT (S)	
72	014680422	2	アタメネジ4.37クホミ	SET SCREW 4.37	
73	S03321001	1	オサエウテストップ	PRESSER ARM STOPPER	
74	062711012	1	ナヘコ476-32X10	SCREW 476X10	

M. トリミングメス関係 (CB2710, 2720-0071, 007□<□は1を除く>)/
 Trimming knife mechanism (CB2710, 2720-0071, 007□ -except 1)

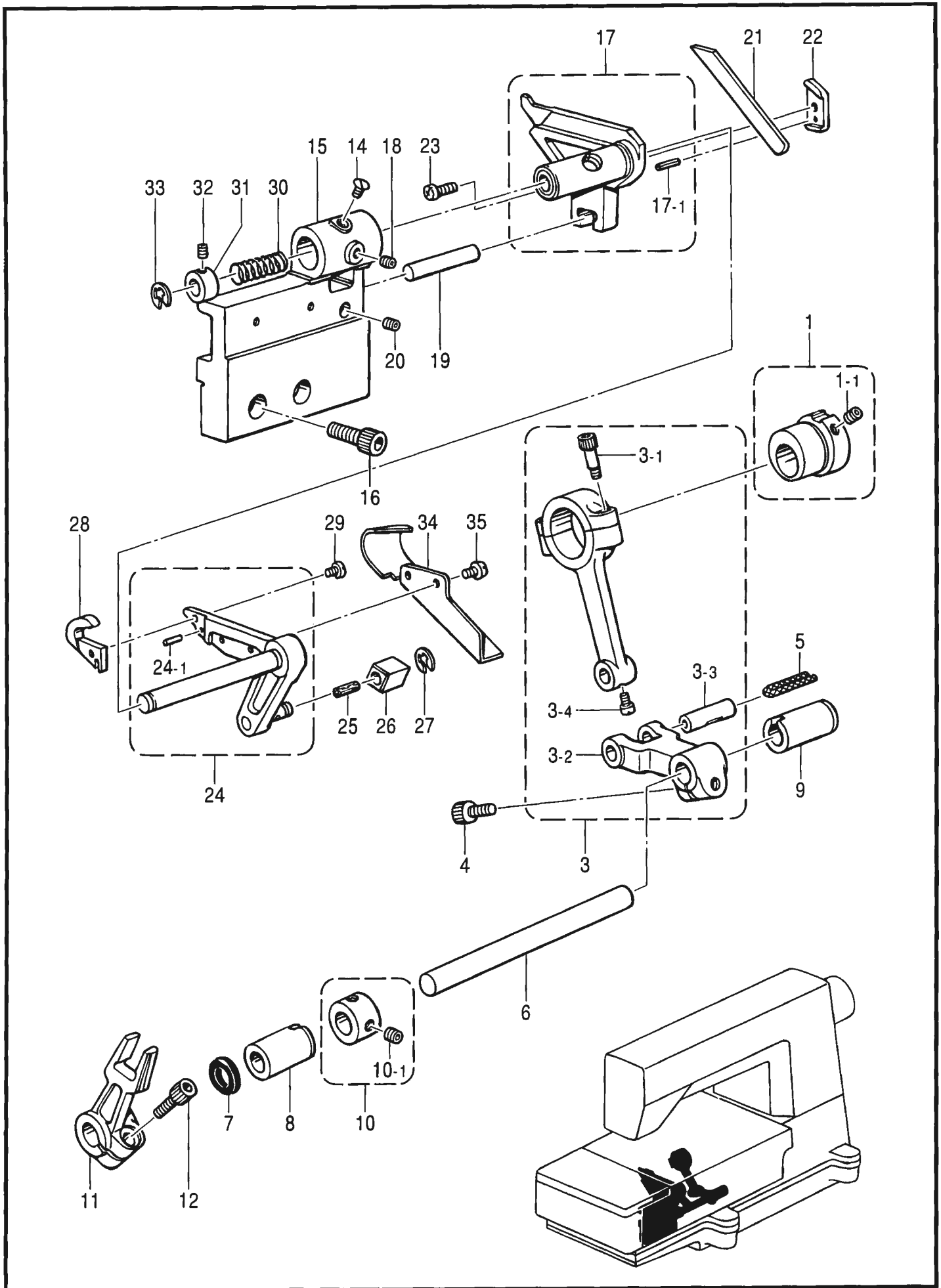

M. トリミングメス関係 (CB2710, 2720 0071, 007)(は1を除く)/
 Trimming knife mechanism (CB2710, 2720-0071, 007 - except 1)

REF.NO	CODE	Q'TY	ヒンメイ	NAME OF PARTS	RMKS
< FOR CB2710, CB2720-0071, 007 - except 1 >					
1	S14094001	1	クト"ウヘンシンリンネシ"ツキ	DRIVING ECCENTRIC WHEEL WITH SCREW	
1-1	014680622	2	アナトメネシ"4.37クホ"ミ	SET SCREW 4.37	
3	S09067001	1	メスクト"ウロツト"クミ	KNIFE DRIVING ROD ASSEMBLY	
3-1	148425001	2	アナホ"ルト4.37X14	BOLT 4.37X14	
3-2	S09069001	1	メスクト"ウウテ"	KNIFE DRIVING ARM	
3-3	140232001	1	ウワメスクランク"ロツト"ヒン	CRANK ROD PIN	
3-4	100366001	1	マルヒラトメネシ"4.37	SET SCREW 4.37	
4	018771432	1	アナホ"ルト635-40X14	BOLT 635X14	
5	140418000	1	クミヒモ	WICK (L=56)	
6	S09070001	1	メスヨウト"ウシ"ク	KNIFE DRIVING SHAFT	
7	155539000	1	ダ"ストシール	DUST SEAL	
8	S08753000	1	ハリウケBシ"クメタルL	KNIFE DRIVING SHAFT BUSH (L)	
9	S08754000	1	ハリウケBシ"クメタルR	KNIFE DRIVING SHAFT BUSH (R)	
10	S03704001	1	セツトカラークミ	SET COLLAR ASSEMBLY	
10-1	014770622	2	アナトメネシ"6.35クホ"ミ	SET SCREW 6.35	
11	S09071001	1	メスクト"ウフタマタ	KNIFE DRIVING FORK	
12	018771432	1	アナホ"ルト635-40X14	BOLT 635X14	
14	108960002	1	サラネシ"3.57	SCREW 3.57	
15	S09072101	1	メスホルダ"ト"ダイ	KNIFE HOLDER BRACKET	
16	018061422	2	アナホ"ルト6X14	BOLT 6X14	
17	S09073101	1	シタメスホルダ"クミ	LOWER KNIFE HOLDER ASSEMBLY	
17-1	047150850	1	スプリング"ヒン"1.4X8	SPRING PIN 1.4X8	
18	014680422	1	アナトメネシ"4.37クホ"ミ	SET SCREW 4.37	
19	155914001	1	シ"ク6X31.8	STUD 6X31.8	
20	014680422	1	アナトメネシ"4.37クホ"ミ	SET SCREW 4.37	
21	S09075001	1	シタメス	LOWER KNIFE	
22	S09076001	1	シタメスオサエ	LOWER KNIFE PRESSER PLATE	
23	062681012	1	ナヘ"コ437-40X10	SCREW 437X10	
24	S09077001	1	ウワメスホルダ"クミ	UPPER KNIFE HOLDER ASSEMBLY	
24-1	149604001	1	ヒン"1.5X5.8	PIN 1.5X5.8	
25	146740000	1	フェルトS	FELT (S)	
26	S09079000	1	カクゴ"マ	SLIDE BLOCK	
27	048050342	1	トメワE5	STOP RING E5	
28	S09080001	1	ウワメス	UPPER KNIFE	
29	150755001	1	シメネシ"3.18	SCREW 3.18	
30	S09055001	1	ローラアツハ"ネ	SPRING	
31	110243001	1	ヌノオサエカラー	COLLAR	
32	102716004	1	トメネシ"4.37	SET SCREW 4.37	
33	048050342	1	トメワE5	STOP RING E5	
34	S09081001	1	キリクス"アンナイ	CHIP GUIDE	
35	062660512	2	ナヘ"コネシ"318-40X5	SCREW 318X5	

N. ベルトループメス関係 (CB2710-00U1, 00U2) /
Belt loop knife mechanism (CB2710-00U1, 00U2)

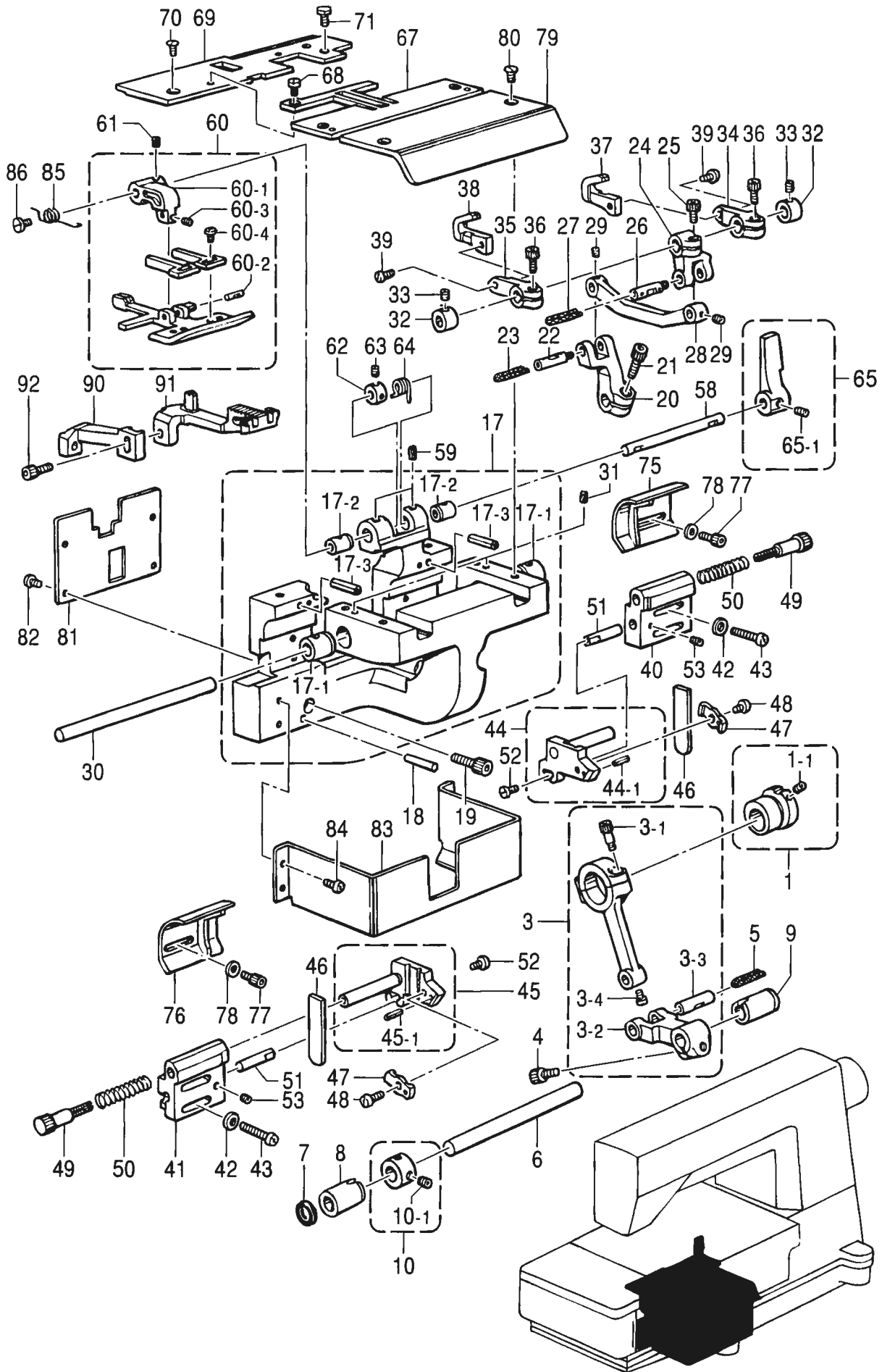

N. ベルトループメス関係 (CB2710-00U1, 00U2) / Belt loop knife mechanism (CB2710-00U1, 00U2)

REF.NO.	CODE	Q'TY	ヒンメイ	NAME OF PARTS	RMKS
1	S14094001	1	クト"ウヘンジンリンネジ"ツキ	DRIVING ECCENTRIC WHEEL WITH SCREW	
1-1	014680622	2	アナトメネジ"4.37クホ"ミ	SET SCREW 4.37	
3	S09067001	1	メスクト"ウロツト"クミ	KNIFE DRIVING ROD ASSEMBLY	
3-1	148425001	2	アナホ"ルト4.37X14	BOLT 4.37X14	
3-2	S09069001	1	メスクト"ウウテ"	KNIFE DRIVING ARM	
3-3	140232001	1	ウワメスクランクロツト"ヒン	CRANK ROD PIN	
3-4	100366001	1	マルヒラトメネジ"4.37	SET SCREW 4.37	
4	018771432	1	アナホ"ルト635-40X14	BOLT 635X14	
5	140418000	1	クミヒモ	WICK (L=56)	
6	S09070001	1	メスヨウト"ウシ"ク	KNIFE DRIVING SHAFT	
7	155539000	1	タ"ストシール	DUST SEAL	
8	S08753000	1	ハソウケBシ"クメタルL	KNIFE DRIVING SHAFT BUSH (L)	
9	S08754000	1	ハソウケBシ"クメタルR	KNIFE DRIVING SHAFT BUSH (R)	
10	S03704001	1	セツトカラークミ	SET COLLAR ASSEMBLY	
10-1	014770622	2	アナトメネジ"6.35クホ"ミ	SET SCREW 6.35	
17	S09082001	1	ヘルトループト"タ"イクミ	BELT LOOP BASE ASSEMBLY	
17-1	S09084000	2	メスシ"クメタル	KNIFE SHAFT BUSH	
17-2	S09085000	2	マエオサエメタル	FRONT PRESSER SHAFT BUH	
17-3	047402042	2	スプリング"ヒン"A4	SPRING PIN (A4)	
18	107752000	2	テーパ"ヒン	TAPER PIN	
19	018061222	2	アナホ"ルト6X12	BOLT 6X12	
20	S09086001	1	メスクト"ウレハ"-D	KNIFE DRIVING LEVER (D)	
21	018771432	1	アナホ"ルト635-40X14	BOLT 635X14	
22	S09087001	1	メスクト"ウヒン	KNIFE DRIVING PIN	
23	117006001	1	クミヒモ	WICK (L=60)	
24	S09088001	1	メスクト"ウレハ"-U	KNIFE DRIVING LEVER (U)	
25	018681022	1	アナホ"ルト4.37X10	BOLT 4.37X10	
26	S09087001	1	メスクト"ウヒン	KNIFE DRIVING PIN	
27	117006001	1	クミヒモ	WICK (L=60)	
28	S09089001	1	ウワメスクト"ウロツト"	UPPER KNIFE DRIVING ROD	
29	014680422	2	アナトメネジ"4.37クホ"ミ	SET SCREW 4.37	
30	S09090001	1	メスシ"ク	KNIFE SHAFT	
31	146740000	2	フェルトS	FELT (S)	
32	110243001	2	ヌノオサエカラー	COLLAR	
33	102716004	2	トメネジ"4.37	SET SCREW 4.37	
34	S09091001	1	ウワメスホルダ"R	UPPER KNIFE HOLDER (R)	
35	S09092001	1	ウワメスホルダ"L	UPPER KNIFE HOLDER (L)	
36	018681022	2	アナホ"ルト4.37X10	BOLT 4.37X10	
37	S09093001	1	ウワメスR	UPPER KNIFE (R)	
38	S09094001	1	ウワメスL	UPPER KNIFE (L)	
39	062670712	2	ナヘ"コ357-40X7	SCREW 357X7	
40	S09095001	1	シタメスホルダ"ササエR	LOWER KNIFE HOLDER SUPPORT (R)	
41	S09096001	1	シタメスホルダ"ササエL	LOWER KNIFE HOLDER SUPPORT (L)	
42	113431002	4	サ"カ"ネ	WASHER	
43	062712012	4	ナヘ"コ476-32X20	SCREW 476X20	
44	S09097001	1	シタメスホルダ"Rクミ	LOWER KNIFE HOLDER (R) ASSEMBLY	
44-1	047140842	1	スプリング"ヒン"1.4X8	SPRING PIN 1.4X8	
45	S09099001	1	シタメスホルダ"Lクミ	LOWER KNIFE HOLDER (L) ASSEMBLY	
45-1	047140842	1	スプリング"ヒン"1.4X8	SPRING PIN 1.4X8	
46	S09101001	2	シタメス	LOWER KNIFE	
47	S09102001	2	シタメスオサエ	LOWER KNIFE PRESSER PLATE	
48	062680812	2	ナヘ"コ437-40X8	SCREW 437X8	
49	S09103001	2	チヨウセツネジ"	ADJUST SCREW	
50	147843001	2	ラツクモト"シハ"ネ	RACK RETURN SPRING	
51	S09104001	2	マワリト"メ	STOPPER SHAFT	
52	112751003	2	シメネジ"3.57	SCREW 3.57	
53	014680422	2	アナトメネジ"4.37クホ"ミ	SET SCREW 4.37	
58	S09105001	1	マエオサエシ"ク	FRONT PRESSER SHAFT	
59	S09043000	2	フェルト	FELT	

N. ベルトループメス関係 (CB2710-00U1, 00U2) /
 Belt loop knife mechanism (CB2710-00U1, 00U2)

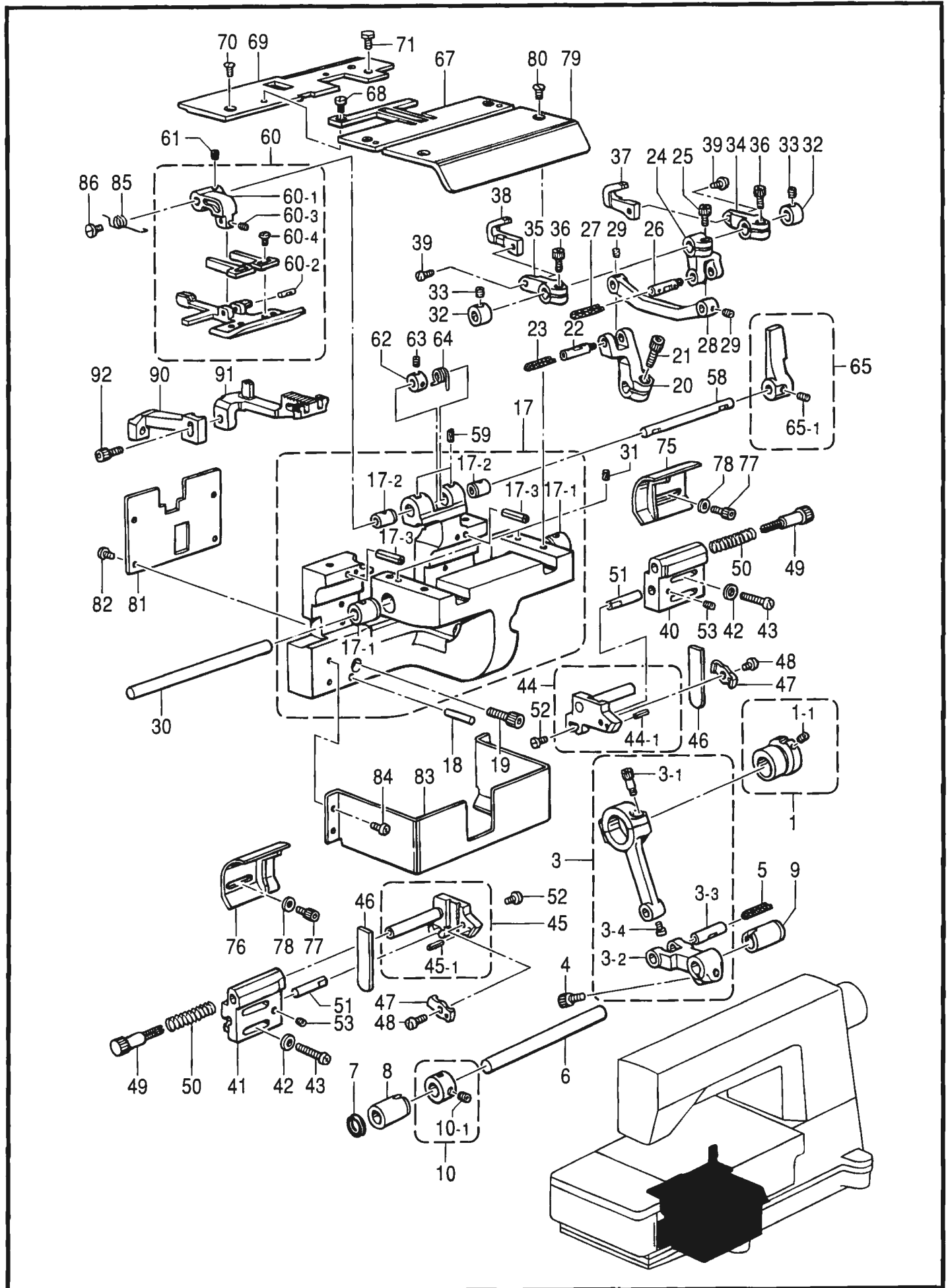

N. ベルトループメス関係 (CB2710 00U1, 00U2)/ Belt loop knife mechanism (CB2710-00U1, 00U2)

REF NO	CODE	Q'TY	ヒンメイ	NAME OF PARTS	RMKS
60	S09106101	1	マエオサエクミ	FRONT PRESSER ASSEMBLY	
60 1	S09107101	1	マエオサエウデ	FRONT PRESSER ARM	
60 2	S11445001	1	オサエヒンジ"シ"ク	HINGE SHAFT	
60-3	S01374001	1	トメネジ"2.38クホ"ミ	SET SCREW 2.38	
60-4	062660512	2	ナヘ"コネジ"318-40X5	SCREW 318X5	
61	014680422	2	アナトメネジ"4.37クホ"ミ	SET SCREW 4.37	
62	S09110001	1	マエオサエカラー	FRONT PRESSER COLLAR	
63	153675001	2	アナトメネジ"4.37	SET SCREW 4.37	
64	S09111001	1	マエオサエハ"ネ	FRONT PRESSER SPRING	
65	S13103009	1	オサエアケ"テコネジ"ツキ	PRESSER BAR LIFTER WITH SCREW	
65-1	014710522	2	アナトメネジ"4.76クホ"ミ	SET SCREW 4.76	
67	S09112001	1	メスイタ	KNIFE PLATE	
68	100257010	3	シメネジ"3.57	SCREW 3.57	
69	S09113001	1	ラツハ"ト"タイ	LAPPER BASE	
70	107231002	1	サラネジ"4.76	SCREW 4.76	
71	146360002	1	ボ"ルト4.76X7	BOLT 4.76X7	
75	S09114001	1	キリクス"アンナイR	CHIP GUIDE (R)	
76	S09115001	1	キリクス"アンナイL	CHIP GUIDE (L)	
77	018400632	2	アナボ"ルト4X6	BOLT 4X6	
78	110735002	2	サ"カ"ネ	WASHER	
79	S09116001	1	ゼ"ンメンカハ"ー	FRONT FACE COVER	
80	107231002	2	サラネジ"4.76	SCREW 4.76	
81	S09117001	1	ハイメンカハ"ー	REAR COVER	
82	062680612	4	ナヘ"コ437-40X6	SCREW 437X6	
83	S09022009	1	ヌノトシイタ	MATERIAL DROP PLATE	
84	062670612	4	ナヘ"コ357-40X6	SCREW 357X6	
85	S09500001	1	マエオサエホジ"ヨハ"ネ	SPRING	
86	148834001	1	シメネジ"3.57	SCREW 3.57	
90	S09118001	1	マエオクリハ"ト"タイ	FRONT FEED DOG BRACKET	
91	S09119001	1	マエオクリハ"	FRONT FEED DOG	
92	018681022	1	アナボ"ルト4.37X10	BOLT 4.37X10	

P1 . パルスモータ式上ゴム送り関係 (センサー) (CB2710, 2720-007□<□は1を除く>) /
Pulse motor drive top metering mechanism (For sensor) (CB2710, 2720-007□-except 1)

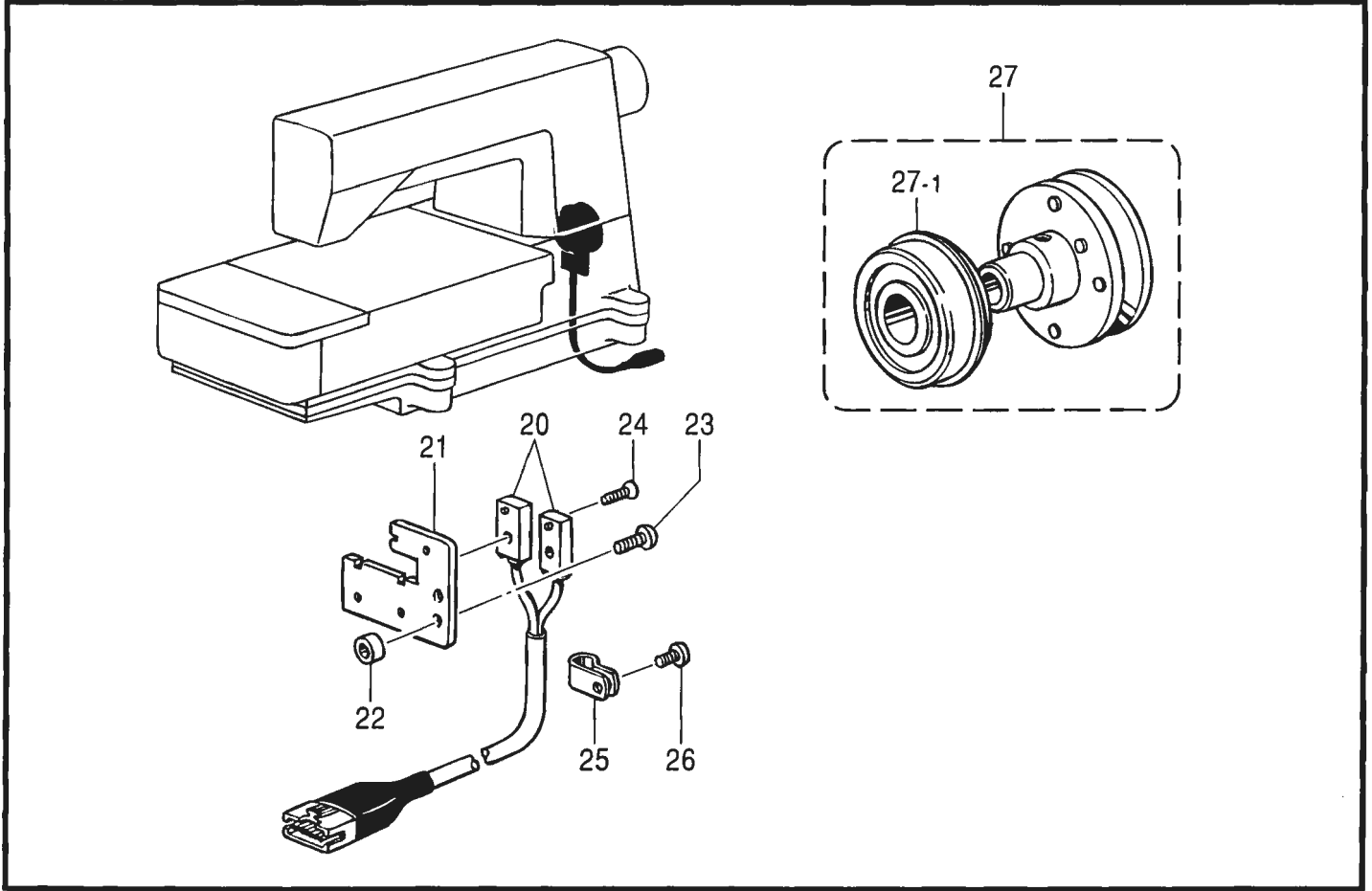

118-271-955

P1. パルスモータ式上ゴム送り関係 (センサー) (CB2710, 2720 007)(は1を除く)/
Pulse motor drive top metering mechanism (For Sensor) (CB2710, 2720-007 - except 1)

REF NO	CODE	Q'TY	ヒンメイ	NAME OF PARTS	RMKS
20	S18808009	1	ハリカス"センサー"クミ	NUMBER OF STITCH SENSOR ASSEMBLY	
21	S18810001	1	センサートリツケイタ	SENSOR SET PLATE	
22	S03303001	2	カラー	COLLAR	
23	062681212	2	ナヘ"コ437-40X12	SCREW 437X12	
24	S10856001	2	+ サラネジ"2X8	SCREW 2X8	
25	149547000	1	コード"オサエ	CORD HOLDER (4N)	
26	062680712	1	ナヘ"コ437-40X7	SCREW 437X7	
27	S18806001	1	Vヘルトプーリックミ	V-BELT PULLEY ASSEMBLY	
27-1	076304850	1	タマシ"クウケ6304ZZ	BALL BEARING 6304ZZ	

P2 . パルスモータ式上ゴム送り関係 (上ゴム送り) (CB2710, 2720-007□<□は1を除く>) /
 Pulse motor drive top metering mechanism (For upper rubber feed)(CB2710, 2720-007□ -except 1)

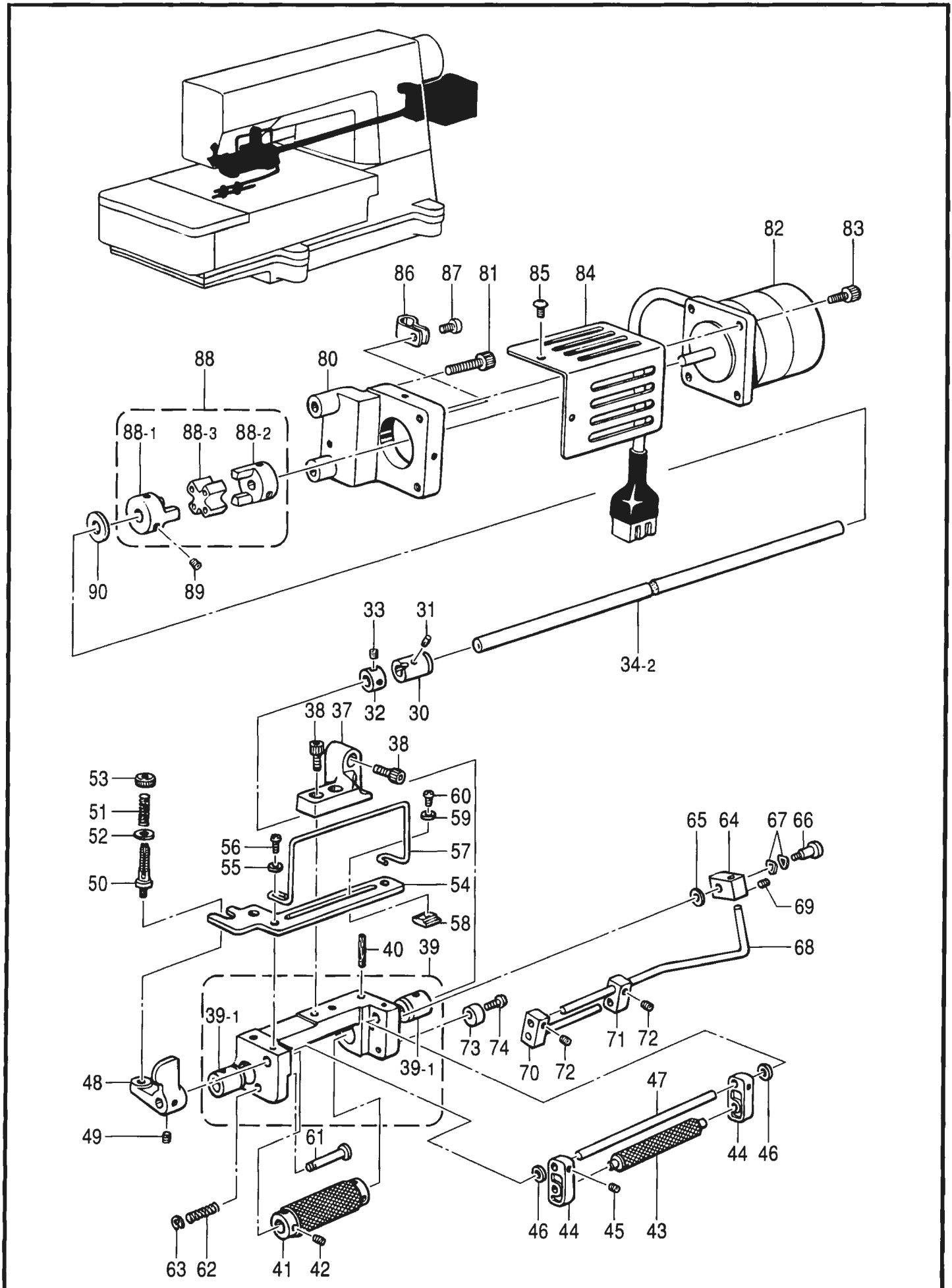

P2. パルスモータ式上ゴム送り関係(上ゴム送り)(CB2710, 2720 007)(は1を除く)/

Pulse motor drive top metering mechanism (For upper rubber feed) (CB2710, 2720-007 - except 1)

REF NO	CODE	Q'TY	ヒンメイ	NAME OF PARTS	RMKS
30	S09042000	1	ゴムオクリメタルR	RUBBER FEED SHAFT BUSH (R)	
31	S09043000	1	フェルト	FELT	
32	110197001	1	ゼットカラー	SET COLLAR	
33	153675001	2	アナトメネジ"4.37	SET SCREW 4.37	
34-2	S18805001	1	ウフゴムオクリシ"ク	RUBBER FEED SHAFT	
37	S09046001	1	チヨウゼット"タイ	ADJUST BASE	
38	018061222	4	アナホル"ルト6X12	BOLT 6X12	
39	S09047001	1	ウフゴムオクリシ"イクミ	RUBBER FEED BASE ASSEMBLY	
39-1	S09049000	2	ゴムオクリメタルL	RUBBER FEED SHAFT BUSH (L)	
40	147691000	2	フェルト	FELT	
41	S09050001	1	ゴムオクリローラ	RUBBER FEED ROLLER	
42	148294001	4	アナトメネジ"3.57クホ"ミ	SET SCREW 3.57	
43	S09051001	1	テンションローラ	TENSION ROLLER	
44	S09052001	2	テンションローラササエ	TENSION ROLLER SUPPORT	
45	014680422	2	アナトメネジ"4.37クホ"ミ	SET SCREW 4.37	
46	109763002	2	サ"カ"ネ	WASHER	
47	S09053001	1	テンションローラシ"ク	TENSION ROLLER SHAFT	
48	S09054001	1	ローラアゲ"テコ	ROLLER LIFTER LEVER	
49	014680422	2	アナトメネジ"4.37クホ"ミ	SET SCREW 4.37	
50	110820101	1	イトチヨウシホ"ウ	TENSION STUD	
51	S09055001	1	ローラアツハ"ネ	SPRING	
52	025770232	1	ヒラサ"ガ"ネチユウ6.35	PLAIN WASHER 6.35	
53	100136001	1	イトチヨウシナツト	TENSION NUT	
54	S09056001	1	ゴムガ"イト"イタ	RUBBER GUIDE PLATE	
55	148847001	2	サ"カ"ネ	WASHER	
56	062681012	2	ナヘ"コ437-40X10	SCREW 437X10	
57	S09057001	1	ゴムガ"イト"M	RUBBER GUIDE (M)	
58	150631001	2	テープ"アンナイ	TAPE GUIDE	
59	025630232	2	ヒラサ"ガ"ネチユウ2.38	PLAIN WASHER 2.38	
60	060630412	2	ハ"イント"238-56X4	SCREW 238X4	
61	S09058001	1	ローラアゲ"ホ"ウ	ROLLER LIFTER BAR	
62	S09059001	1	ローラアゲ"ハ"ネ	SPRING	
63	048030342	1	トメ"フE3	STOP RING E3	
64	S09060001	1	ゴムガ"イト"ササエ	RUBBER GUIDE SUPPORT	
65	148847001	1	サ"カ"ネ	WASHER	
66	141598001	1	タ"ンネジ"4.76	STUD SCREW 4.76	
67	103810002	2	ナミガ"タハ"ネサ"カ"ネ	SPRING WASHER	
68	S09061001	1	ゴムガ"イト"D	RUBBER GUIDE (D)	
69	014680422	2	アナトメネジ"4.37クホ"ミ	SET SCREW 4.37	
70	S09062001	1	ゴムガ"イト"ササエDクミ	RUBBER GUIDE SUPPORT (D) ASSEMBLY	
71	S09065001	1	ゴムガ"イト"Sササエ	RUBBER GUIDE SUPPORT (S)	
72	014680422	2	アナトメネジ"4.37クホ"ミ	SET SCREW 4.37	
73	S03321001	1	オサエウテ"ストツハ"	PRESSER ARM STOPPER	
74	062711012	1	ナヘ"コ476-32X10	SCREW 476X10	
80	S18800009	1	パルスモータ"タイ	PULSE MOTOR BRACKET	
81	018062222	2	アナホル"ルト6X22	BOLT 6X22	
82	S18801009	1	パルスモータクミ	PULSE MOTOR ASSEMBLY	
83	018681022	4	アナホル"ルト4.37X10	BOLT 4.37X10	
84	S18803009	1	パルスモータカバー	PULSE MOTOR COVER	
85	060680712	2	ハ"イント"437-40X7	SCREW 437X7	
86	149547000	1	コート"オサエ	CORD HOLDER #4	
87	062680712	1	ナヘ"コ437-40X7	SCREW 437X7	
88	S20248000	1	カツプ"リンク"クミ	COUPLING ASSEMBLY	
88-1	S20249000	1	カツプ"リンク"L	COUPLING (L)	
88-2	S20250000	1	カツプ"リンク"R	COUPLING (R)	
88-3	S20251000	1	カツプ"リンク"ゴム	COUPLING RUBBER	
89	014710522	4	アナトメネジ"4.76クホ"ミ	SET SCREW 4.76	
90	S09260001	1	スラストリング"A	THRUST RING (A)	

P3 . パルスモータ式上ゴム送り関係 (コントロールボックス) (CB2710, 2720-007□<□は1を除く>)/
 Pulse motor drive top metering mechanism (For control box)(CB2710, 2720-007□-except 1)

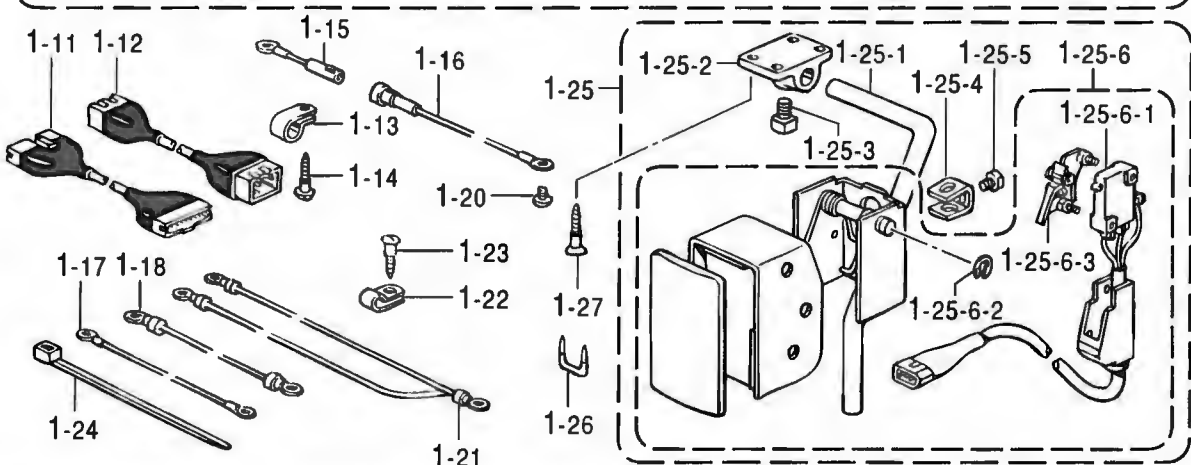
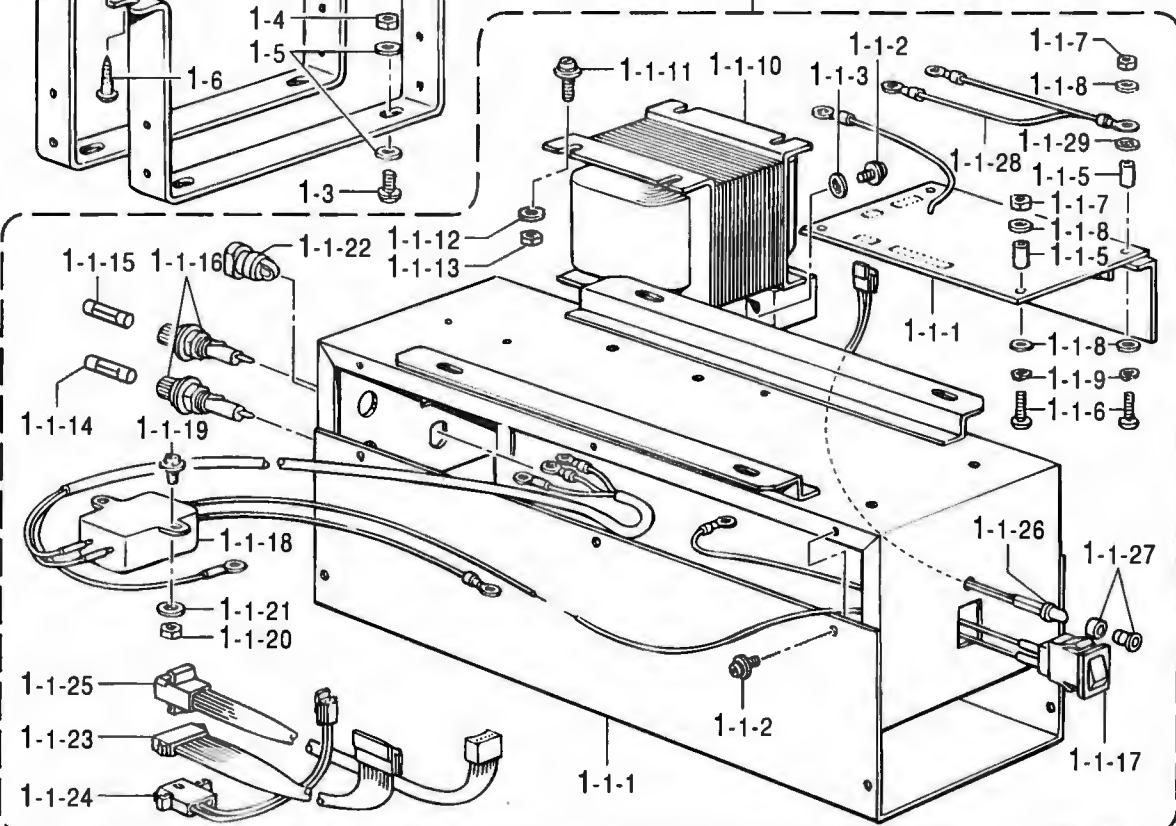
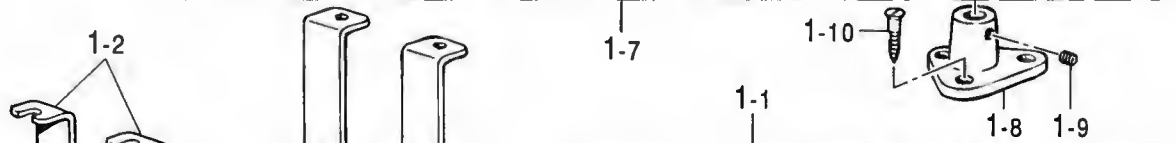
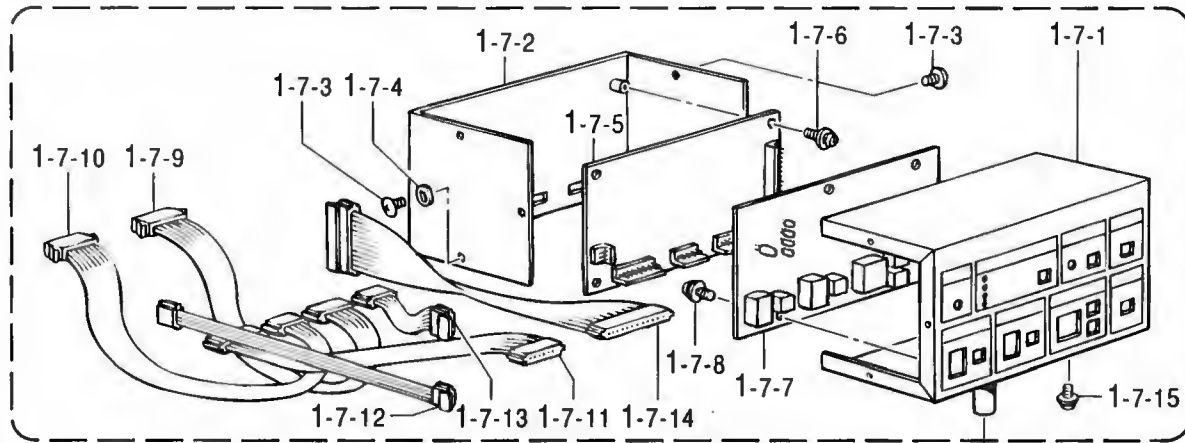

P3. パルスモータ式上ゴム送り関係 (コントロールボックス) (CB2710, 2720 007)(は1を除く)/

Pulse motor drive top metering mechanism (For control box) (CB2710, 2720-007 - except 1)

REF NO	CODE	Q'TY	ヒンメイ	NAME OF PARTS	RMKS
1	*	1	PMコントロールBOXクミ	PULSE MOTOR CONTROL BOX ASSEMBLY	
1 1	*	1	PMデ"ンケ"ンBOXクミ	PULSE MOTOR POWER SUPPLY BOX ASSEMBLY	
1-1-1	S18813009	1	PMデ"ンケ"ンBOXフタ	PULSE MOTOR POWER SUPPLY BOX CAP	
1-1-2	533658001	10	+ナヘ"セムス3X6DB	SCREW 3X6DB	
1-1-3	502677001	1	ハツキサ"ガ"ネ3ウチ	TOOTHED WASHER	
1-1-4	S18814001	1	ト"ライハ"ーキハ"ンクミ	DRIVER CIRCUIT BOARD ASSEMBLY	
1-1-5	S09754000	4	ス"ー"サー(C)	SPACER (C)	
1-1-6	002302203	4	+ナヘ"ネジ"3X22	SCREW 3X22	
1-1-7	021300105	4	1シユナツト3	NUT 3	
1-1-8	025030135	8	ヒラサ"ガ"ネシヨウ3	PLAIN WASHER 3	
1-1-9	028030245	4	ハ"ネサ"ガ"ネ2-3	SPRING WASHER 2-3	
1-1-10	*	1	トランスクミ	TRANSFORMER	
1-1-11	U20018001	4	+ナヘ"セムス4X14DB	SCREW 4X14DB	
1-1-12	025040233	4	ヒラサ"ガ"ネチユウ4	PLAIN WASHER 4	
1-1-13	021400164	4	ナツト1シユ4	NUT 4	
1-1-14	152567000	1	ヒューズ"D	FUSE (D)	
1-1-15	S05072000	1	ヒューズ"3A	FUSE (3A)	
1-1-16	S10944000	2	ヒューズ"ホルダ"ー	FUSE HOLDER	
1-1-17	S18819000	1	スイッチクミ	SWITCH ASSEMBLY	
1-1-18	S18820000	1	コード"クミ	CORD ASSEMBLY	
1-1-19	U22701001	2	+ナヘ"セムス3X8DB	SCREW 3X8DB	
1-1-20	021300105	2	1シユナツト3	NUT 3	
1-1-21	025030135	2	ヒラサ"ガ"ネシヨウ3	PLAIN WASHER 3	
1-1-22	S10942000	1	コード"フ"ツシユ	CORD BUSH	
1-1-23	S18821000	1	ハーネスP1	HARNESS (P1)	
1-1-24	S18822000	1	ハーネスP2	HARNESS (P2)	
1-1-25	S18823000	1	ハーネスP3	HARNESS (P3)	
1-1-26	S18824000	1	LEDクミ	LED ASSEMBLY	
1-1-27	S18354000	1	マウンテイング"クリツフ"	MOUNTING CLIP	
1-1-28	S19842000	1	デ"ンケ"ンBOXアースセン	POWER SUPPLY BOX EARTH WIRE	
1-1-29	502677001	1	ハツキサ"ガ"ネ3ウチ	TOOTHED WASHER	
1-2	S18826001	2	BOXトリツケイタA	BOX SET PLATE (A)	
1-3	535808001	4	+ナヘ"セムスネジ"5X14	SCREW 5X14	
1-4	021500205	4	2シユナツト5	NUT 5	
1-5	025050233	8	ヒラサ"ガ"ネチユウ5	PLAIN WASHER 5	
1-6	031482504	4	マルモク48X25	SCREW 48X25	
1-7	S18827009	1	セイキ"ヨB0Xクミ	CONTROL BOX ASSEMBLY	
1-7-1	S18828009	1	セイキ"ヨB0Xタイ	CONTROL BOX BASE	
1-7-2	S18829009	1	セイキ"ヨB0Xフタ	CONTROL BOX CAP	
1-7-3	008300604	6	+トラスユ3X6	SCREW 3X6	
1-7-4	502677001	1	ハツキサ"ガ"ネ3ウチ	TOOTHED WASHER	
1-7-5	S18830000	1	キハ"ンB438055クミ	CIRCUIT BOARD B438055 ASSEMBLY	
1-7-6	U03292001	4	+ナヘ"セムス3X7DA	SCREW 3X7DA	
1-7-7	S18831000	1	キハ"ンB438057クミ	CIRCUIT BOARD B438057 ASSEMBLY	
1-7-8	U03292001	4	+ナヘ"セムス3X7DA	SCREW 3X7DA	
1-7-9	S18832000	1	ハーネスC-1	HARNESS (C-1)	
1-7-10	S18833000	1	ハーネスC-2	HARNESS (C-2)	
1-7-11	S18834000	1	ハーネスC-3	HARNESS (C-3)	
1-7-12	S18835000	1	ハーネスC-4	HARNESS (C-4)	
1-7-13	S18836000	1	ハーネスC-5	HARNESS (C-5)	
1-7-14	S18837000	1	ハーネスC-6	HARNESS (C-6)	
1-7-15	533658001	1	+ナヘ"セムス3X6DB	SCREW 3X6DB	
1-8	S09008009	1	シチユウト"タイ	TAPE BASE POST BRACKET	
1-9	014780622	1	アナトメネジ"6.35クホ"ミ	SET SCREW 6.35	
1-10	100447001	3	サラモクネジ"4.5X3.2	SCREW 4.5X3.2	
1-11	S18838000	1	ハーネスA	HARNESS (A)	
1-12	S18839000	1	ハーネスB	HARNESS (B)	
1-13	554482000	4	コード"ホルダ"ー#12	CORD HOLDER #12	
1-14	101118001	4	マルモクネジ"4.5X20	SCREW 4.5X20	
1-15	S11633000	1	アースセン1	EARTH WIRE (1)	

P3 . パルスモータ式上ゴム送り関係 (コントロールボックス) (CB2710, 2720-007□<□は1を除く>) /
 Pulse motor drive top metering mechanism (For control box)(CB2710, 2720-007□-except 1)

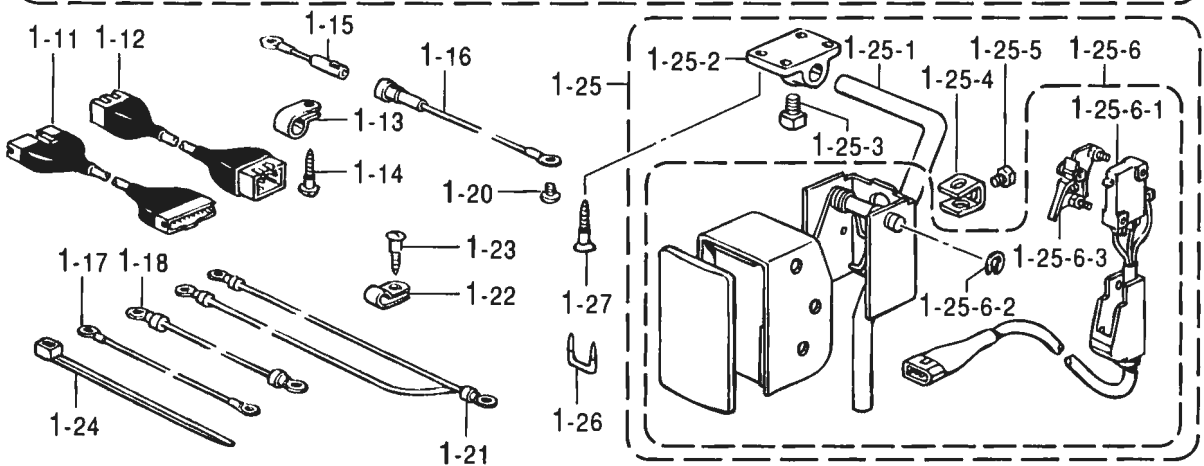
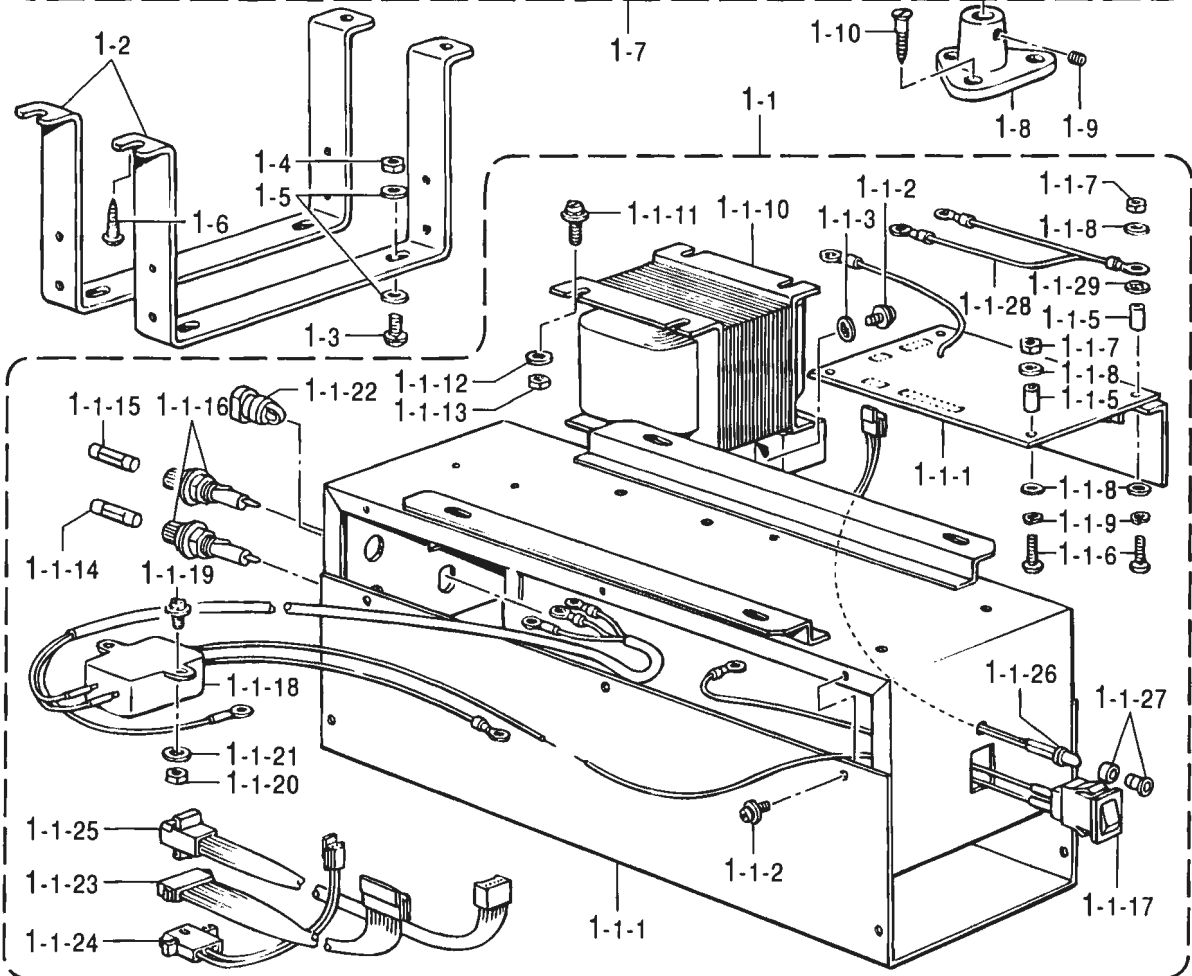
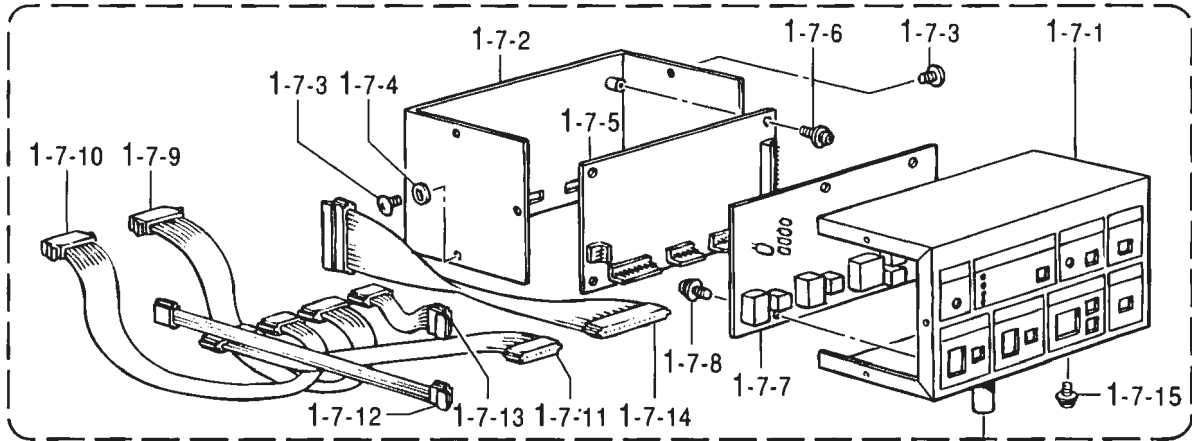

P3. ハルスモータ式上ゴム送り関係 (コントロールボックス) (CB2710, 2720 007)(は1を除く)/
Pulse motor drive top metering mechanism (For control box) (CB2710, 2720-007 - except 1)

REF NO	CODE	Q'TY	ヒンメイ	NAME OF PARTS	RMKS
1-16	S11634000	1	アースセン2	EARTH WIRE (2)	
1-17	S11635000	1	アースセン3	EARTH WIRE (3)	
1-18	S18840000	1	アースセン5	EARTH WIRE (5)	
1-20	062680712	2	ナヘ"コ437-40X7	SCREW 437X7	
1-21	S18842000	1	アースセン7	EARTH WIRE (7)	
1-22	525907000	1	コード"ホルダ"ー#9	CORD HOLDER #9	
1-23	031411304	1	マルモクネシ"4.1X13	SCREW 4.1X13	
1-24	S04159000	6	バンド"1M	BAND 1M	
1-25	147776001	1	ヒザ"スイッチクミ	KNEE SWITCH ASSEMBLY	
1-25-1	147774001	1	ヒザ"スイッチタテシ"ク	KNEE SWITCH SHAFT	
1-25-2	142027001	1	ヒザ"スイッチタテシ"クウケ	KNEE SWITCH SHAFT BRACKET	
1-25-3	100463001	1	4カクホル"ト7.94	BOLT 7.94	
1-25-4	114967001	1	ヒザ"アテストツパ"	KNEE LIFTER PLATE STOPPER	
1-25-5	110087001	1	ホル"ト5.95	BOLT 5.95	
1-25-6	147835001	1	ヒザ"SWケースカバ"ークミ	KNEE SWITCH CASE COVER ASSEMBLY	
1-25-6-1	147826001	1	マイクロスイッチクミ	MICRO SWITCH ASSEMBLY	
1-25-6-2	048060342	2	トメワE6	STOP RING E6	
1-25-6-3	142030000	1	アクチエ"ータ	ACTUATOR	
1-26	200190001	8	ステツ"プル	STAPLE	
1-27	034422503	4	+ サラモクネシ"4.1X25	SCREW 4.1X25	

* 印はボルト (V) によって部品コードが違います。
* Parts marked with (V) differ by the voltage rating.

REF. NO.	VOLTAGE	100	200	110	220	230	240	380	415	
1	P.M.-コントロール BOX クミ P.M.-CONTROL BOX ASSEMBLY	S18811101	S18811102	S18811103	S18811104	S18811105	S18811106	S18811107	S18811108	
1-1	P.M.-デンゲン BOX クミ P.M.-POWER SUPPLY BOX ASSEMBLY	S18844009	S18845009	S18846009	S18847009	S18848009	S18849009	S18850009	S18851009	
1-1-10	トランスクミ TRANSFORMER ASSEMBLY	S18817000					S18818000			

P4 . パルスモータ式上ゴム送り関係 (オプション) /
 Pulse motor drive top metering mechanism (Option)

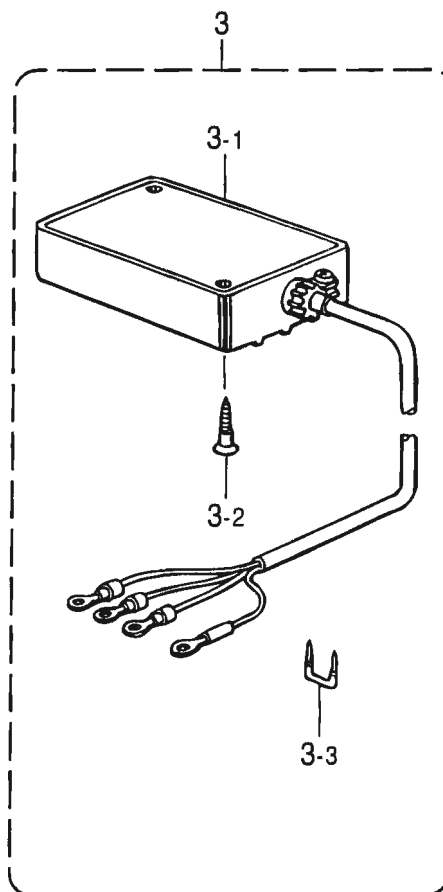
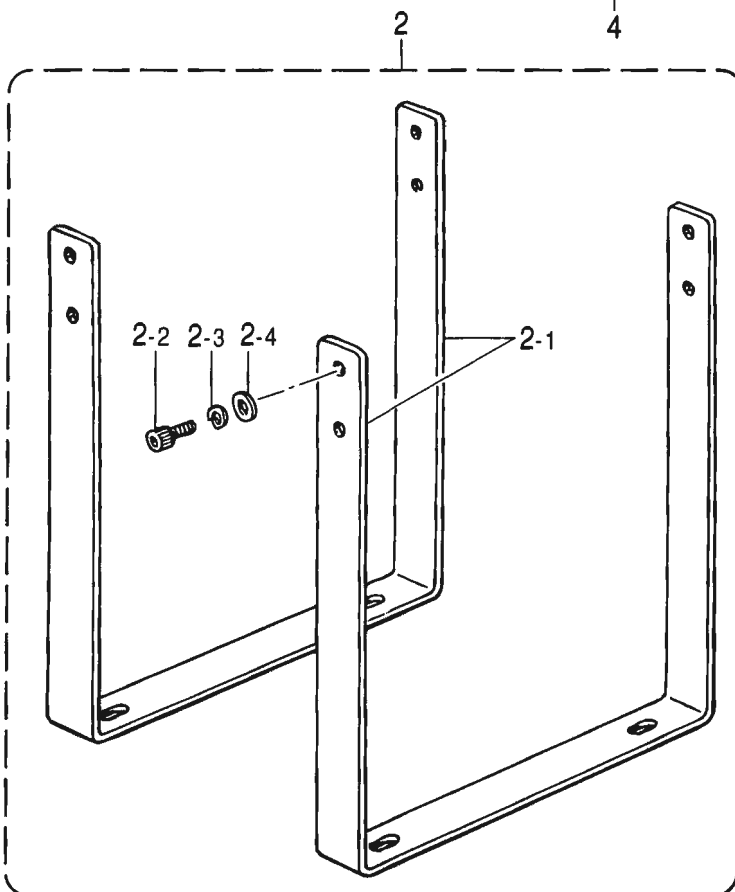
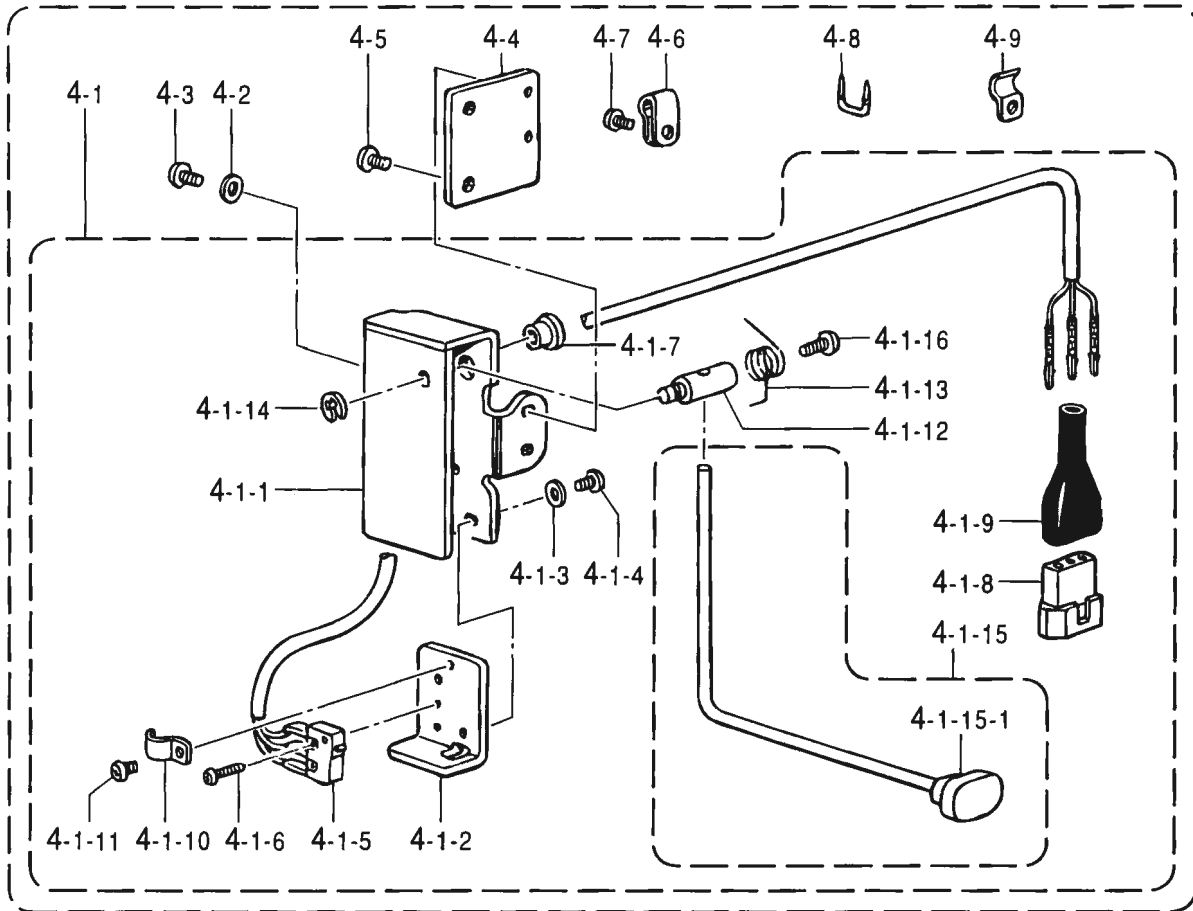

P4. バルスモータ式上ゴム送り関係 (オプション)/Pulse motor drive top metering mechanism (Option)

REF.NO.	CODE	Q'TY	ヒンメイ	NAME OF PARTS	RMKS
2	S18852001	1	B0XトリツケイタBクミ	BOX SET PLATE (B) ASSEMBLY	
2-1	S18853001	2	B0XトリツケイタB	BOX SET PLATE (B)	
2-2	018501022	8	アナボルト5X10	BOLT 5X10	
2-3	028050242	8	ハ"ネサ"カ"ネ2-5	SPRING WASHER 2-5	
2-4	146354001	8	サ"カ"ネ	WASHER	
3	S18854001	1	シ"ヨイントホ"ツクスクミ	JOINT BOX ASSEMBLY	
3-1	S18855000	1	シ"ヨイントホ"ツクス	JOINT BOX	
3-2	034422006	2	+2サラモク41X20	SCREW 41X20	
3-3	200190001	3	ステツフル	STAPLE	
4	S18962001	1	シユト"ウスイツチセツト	PUSH BOTTUN SWITCH SET	
4-1	S18922001	1	シユト"ウスイツチクミ	PUSH BOTTUN SWITCH ASSEMBLY	
4-1-1	S13351009	1	RSイツチダイ	REVERSE SWITCH BRACKET	
4-1-2	S13355001	1	RSイツチイタ	REVERSE SWITCH PLATE	
4-1-3	025350332	2	ヒラサ"カ"ネタ"イ3.5	PLAIN WASHER 3.5	
4-1-4	062670712	2	ナヘ"コ357-40X7	SCREW 357X7	
4-1-5	S18928001	1	RSイツチクミ	REVERSE SWITCH ASSEMBLY	
4-1-6	062630812	2	ナヘ"コ238-56X8	SCREW 238X8	
4-1-7	146080009	1	コート"フ"シユ	CORD BUSH	
4-1-8	143484000	1	ナイロンコネクター	NYLON CONNECTOR	
4-1-9	143485001	1	コネクタキャツプ	CONNECTOR CAP	
4-1-10	140647001	1	コート"オサイ	CORD HOLDER	
4-1-11	062670412	1	ナヘ"コ357-40X4	SCREW 357X4	
4-1-12	156998001	1	アクチュエーターシク	ACTUATOR SHAFT	
4-1-13	S13354001	1	ハ"ーモト"シハ"ネ	SPRING	
4-1-14	048040342	1	トメフE4	STOP RING E4	
4-1-15	S18923001	1	アクチュエータクミ	ACTUATOR ASSEMBLY	
4-1-15-1	156479009	1	オシボ"タン	BUTTON	
4-1-16	062681012	1	ナヘ"コ437-40X10	SCREW 437X10	
4-2	025350332	2	ヒラサ"カ"ネタ"イ3.5	PLAIN WASHER 3.5	
4-3	062670612	2	ナヘ"コ357-40X6	SCREW 357X6	
4-4	S18946001	1	シユト"ウスイツチトリツケイタ	PUSH BOTTUN SWITCH SET PLATE	
4-5	062680712	2	ナヘ"コ437-40X7	SCREW 437X7	
4-6	S10243000	3	ナイロンランプ"NK-3N	CORD HOLDER NK-3N	
4-7	062680712	3	ナヘ"コ437-40X7	SCREW 437X7	
4-8	200190001	1	ステツフル	STAPLE	
4-9	S19843001	1	コート"オサイ	CORD HOLDER	

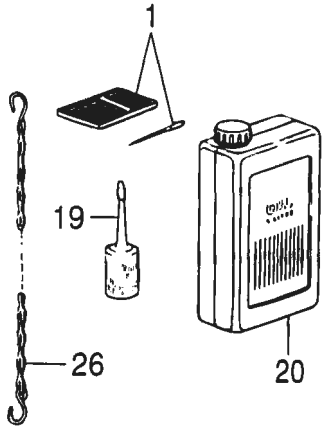
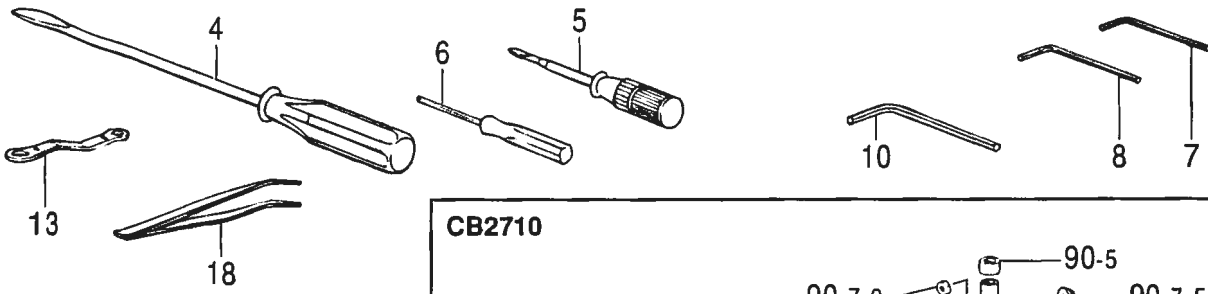

CB2710

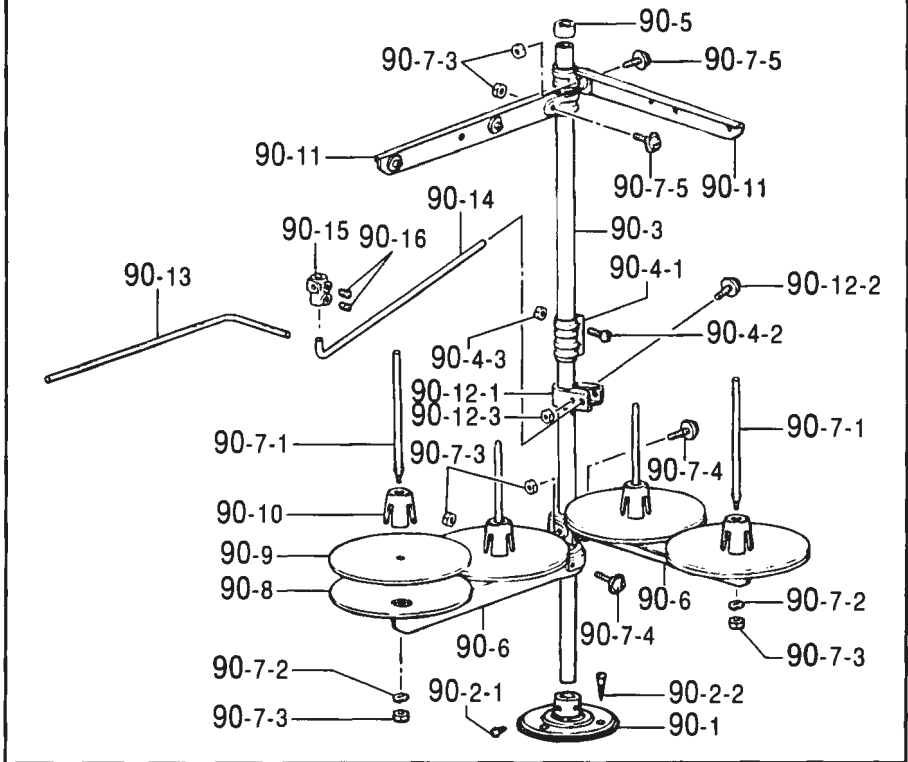

" オプション部品 / OPTION PARTS "

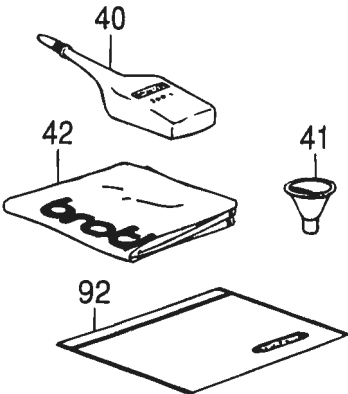
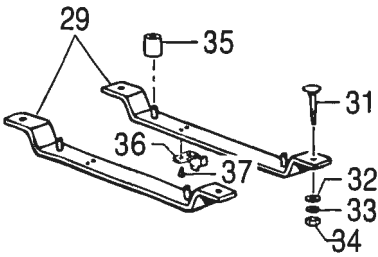
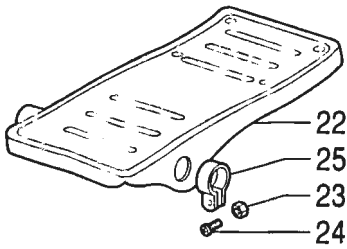

CB2720

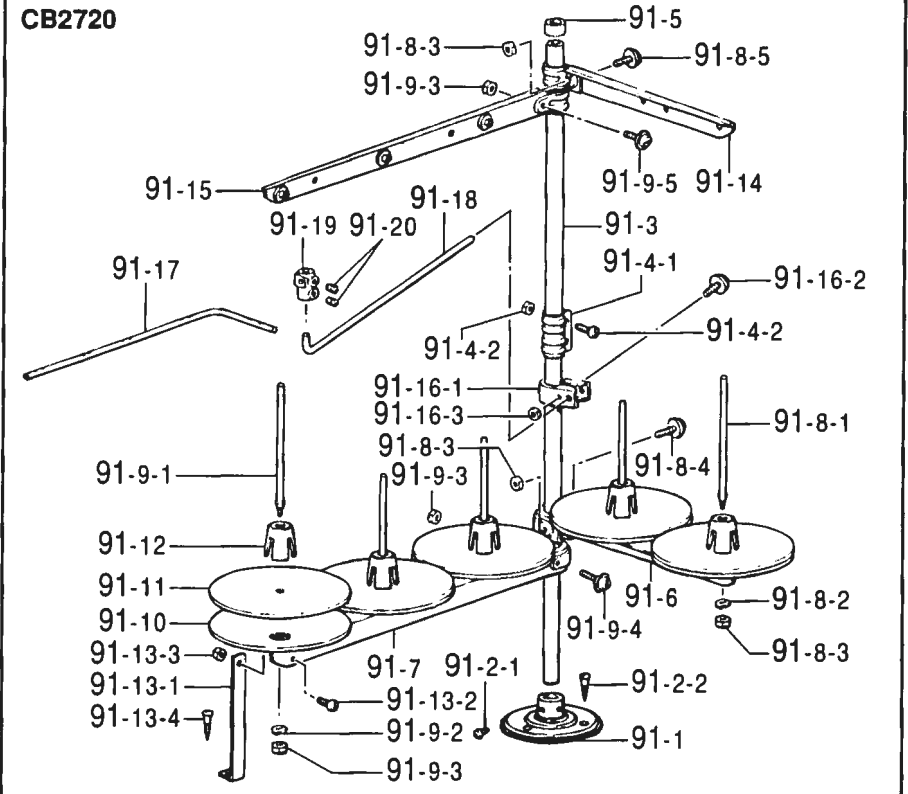

◎ 付属品の明細は変更することがあります。
 ◎ The details of included accessories are subject to change.

Z1. 付属品関係/Accessories

REF NO	CODE	Q'TY	ヒンメイ	NAME OF PARTS	RMKS
4	101572101	1	ネジ"マフシ5.5X190	SCREW DRIVER 5.5X190	
5	118837001	1	ネジ"マフシ3.4X70	SCREW DRIVER 3.4X70	
6	S01943001	1	6カクホ"ウネジ"マフシ1.6	SCREW DRIVER 1.6	
7	146049001	1	6カクホ"ウスハ"ナ2	HEXAGONAL WRENCH 2	
8	142721001	1	6カクホ"ウスハ"ナ3	HEXAGONAL WRENCH 3	
10	150335001	1	6カクホ"ウスハ"ナ5	HEXAGONAL WRENCH 5	
13	105343001	1	メガ"ネレンチ8X9	WRENCH 8X9	
18	117466000	1	ピンセット	TWEEZERS	
19	S06701000	1	ホ"リオイルラークミ	POLY OILER ASSEMBLY	
20	145277105	1	オイルタンク	OIL TANK	
26	149247001	1	クサリクミ	CHAIN ASSEMBLY	
29	S25099001	2	トウブ"ウケイタクミ	MACHINE BASE PLATE ASSEMBLY	
31	211964001	4	カクネホ"ルト8X55	BOLT 8X55	
32	025080236	4	ヒラサ"ガ"ネチユウ8	PLAIN WASHER 8	
33	028080242	4	ハ"ネサ"ガ"ネ2-8	SPRING WASHER 2-8	
34	021080106	4	ナツト1シユ8	NUT 8	
35	147919001	4	ホ"ウシンゴ"ム	RUBBER CUSHION	
36	S09001001	1	クサリカ"イト"	CHAIN GUIDE	
37	060680712	2	ハ"イント"437-40X7	SCREW 437X7	
40	S06704001	1	シリコンオイル	SILICONE OIL	
41	140759000	1	シ"ヨーゴ"	FUNNEL	
42	144224001	1	トウブ"カハ"	HEAD COVER	
92	122991001	1	フゾ"クヒンホ"リフクロ	ACCESSORY BAG	
< FOR CB2710 >					
90	S02769109	1	イトタテダ"イクミ4THF	COTTON STAND ASSEMBLY 4THF	
90-1	150189009	1	ブ"ラケット	COTTON STAND BASE	
90-2	S02773001	1	ブ"ラケットネジ"セット	COTTON STAND BASE SCREW SET	
90-2-1	062060806	2	ナヘ"コ6X8	SCREW 6X8	
90-2-2	031452206	3	マルモク45X22	SCREW 45X22	
90-3	150172003	2	コラム"パイプ"	COLUMN PIPE	
90-4	150106003	1	コラムシ"ョイントクミ	COLUMN JOINT ASSEMBLY	
90-4-1	150173003	1	コラムシ"ョイント	COLUMN JOINT	
90-4-2	062501406	2	ナヘ"コ5X14	SCREW 5X14	
90-4-3	021500106	2	1シユナツト5	NUT 5	
90-5	150174000	1	コラムキャツプ"	COLUMN CAP	
90-6	S02778002	2	スプ"ールホルダ"ー2	SPOOL HOLDER 2	
90-7	S02780001	2	スプ"ールネジ"セット2	SPOOL SCREW SET 2	
90-7-1	150179002	4	スプ"ールシ"クB	SPOOL SHAFT (B)	
90-7-2	028050246	4	ハ"ネサ"ガ"ネ2-5	SPRING WASHER 2-5	
90-7-3	021500106	8	1シユナツト5	NUT 5	
90-7-4	050503006	2	ナヘ"コヒラサ"5X30	SCREW 5X30	
90-7-5	050501406	2	ナヘ"コヒラサ"5X14	SCREW 5X14	
90-8	150180001	4	ウケサ"ラ	SPOOL STAND BASE	
90-9	150182000	4	スプ"ールマット	SPOOL MAT	
90-10	126863001	4	スプ"ールクツシヨン	SPOOL CUSHION	
90-11	S02786002	2	スレツト"ハンガ"ークミ2	THREAD HANGER ASSEMBLY 2	
90-12	150145009	1	イトアンナイホルダ"ークミ	THREAD GUIDE HOLDER ASSEMBLY	
90-12-1	150185009	1	イトアンナイホルダ"ー	THREAD GUIDE HOLDER	
90-12-2	050503006	1	ナヘ"コヒラサ"5X30	SCREW 5X30	
90-12-3	021500106	1	1シユナツト5	NUT 5	
90-13	142998001	1	イトアンナイ4	THREAD GUIDE 4	
90-14	S04109001	1	イトアンナイササエホ"ウ	THREAD GUIDE SUPPORT BAR	
90-15	138843001	1	ササエホ"ウツキ"テ	JOINT	
90-16	014060632	2	アナトメ6X6クホ"ミ	SET SCREW 6X6	

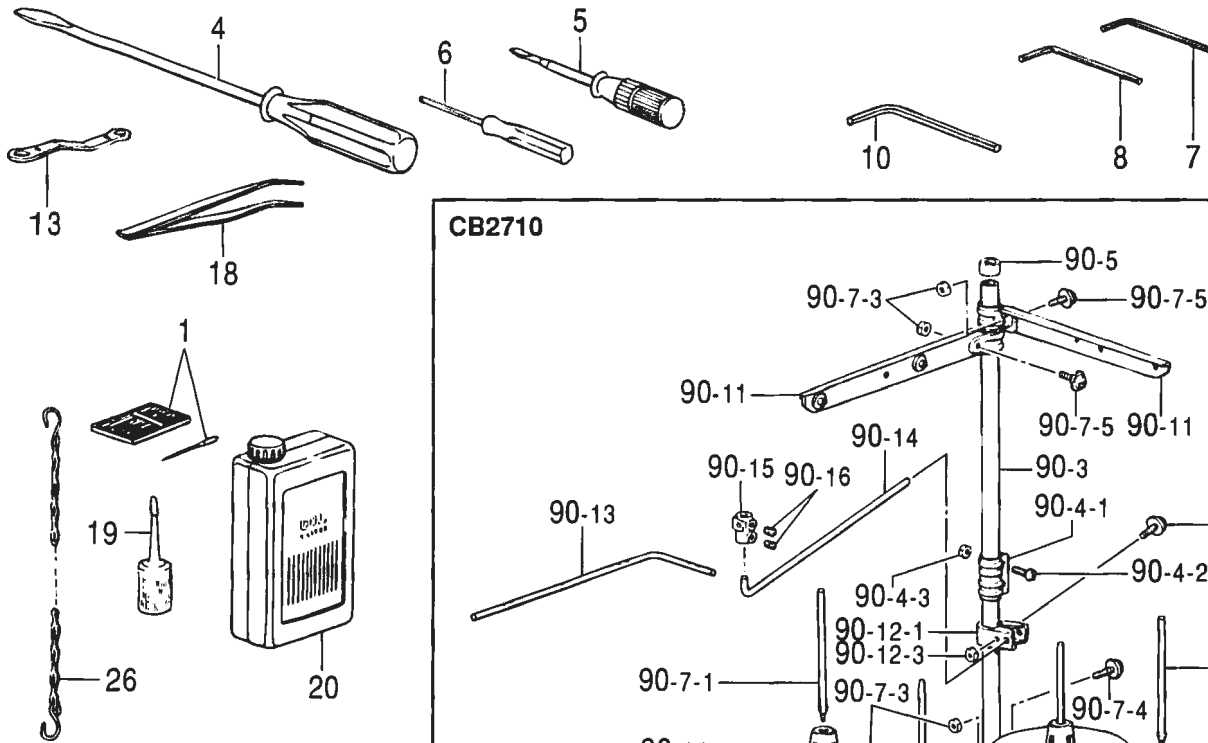

CB2710

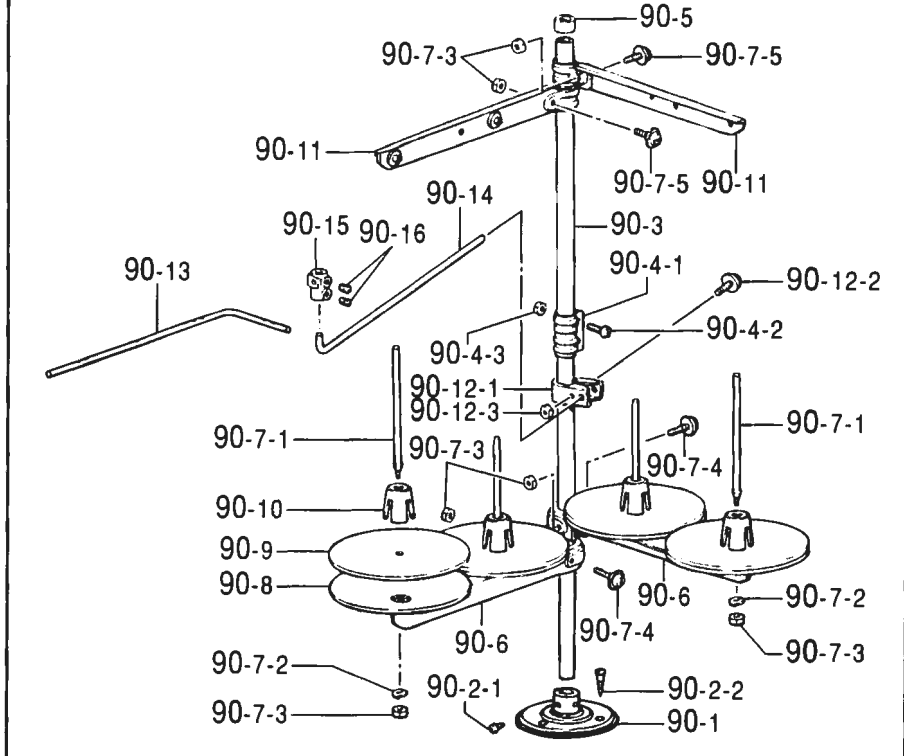

" オプション部品 / OPTION PARTS "

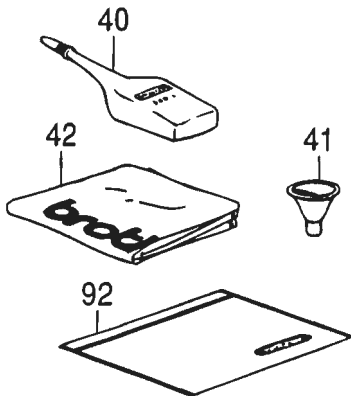
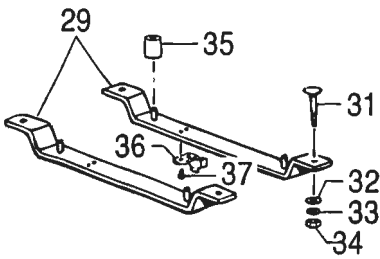
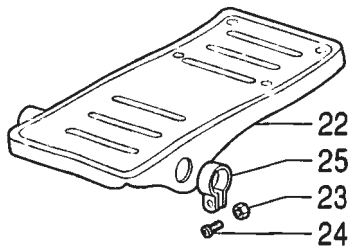

CB2720

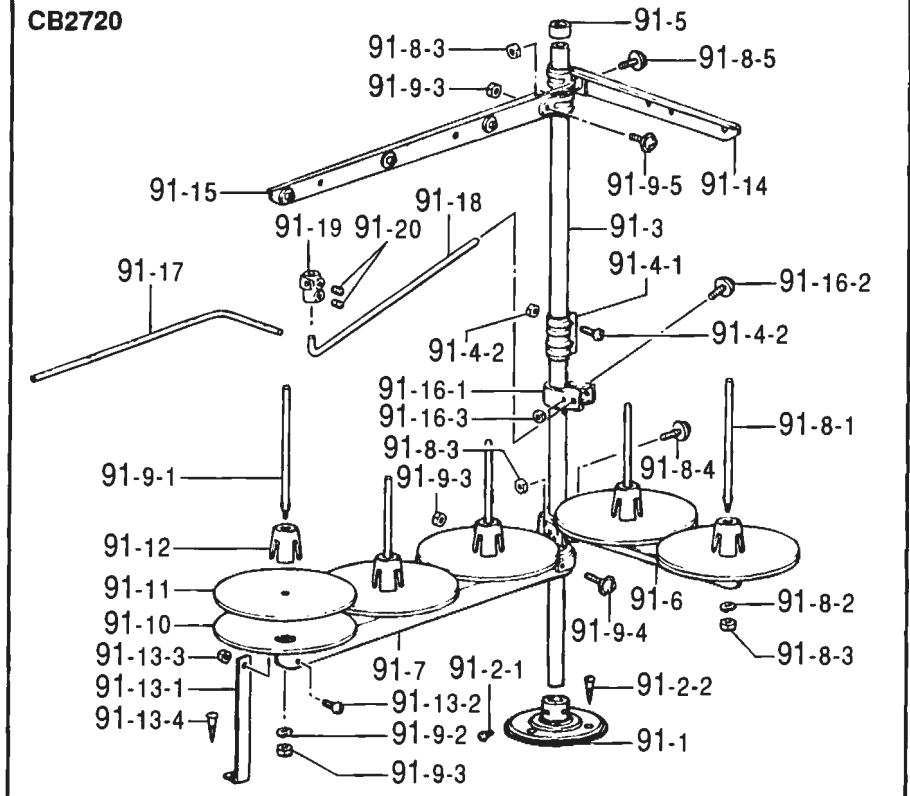

◎ 付属品の明細は変更することがあります。

◎ The details of included accessories are subject to change.

Z1. 付属品関係 / Accessories

REF NO	CODE	Q'TY	ヒンメイ	NAME OF PARTS	RMKS
< FOR CB2720 >					
91	S02770109	1	イトタテダ"イクミ5THF	COTTON STAND ASSEMBLY 5THF	
91-1	150189009	1	ブラケット	COTTON STAND BASE	
91-2	S02773001	1	ブラケットネジ"セット	COTTON STAND BASE SCREW SET	
91-2-1	062060806	2	ナヘ"コ6X8	SCREW 6X8	
91-2-2	031452206	3	マルモク45X22	SCREW 45X22	
91-3	150172003	2	コラムパイプ	COLUMN PIPE	
91-4	150106003	1	コラムジョイントクミ	COLUMN JOINT ASSEMBLY	
91-4-1	150173003	1	コラムジョイント	COLUMN JOINT	
91-4-2	062501406	2	ナヘ"コ5X14	SCREW 5X14	
91-4-3	021500106	2	1シユナツト5	NUT 5	
91-5	150174000	1	コラムキャップ	COLUMN CAP	
91-6	S02778002	1	スプールホルダー"2	SPOOL HOLDER 2	
91-7	S02779009	1	スプールホルダー"3	SPOOL HOLDER 3	
91-8	S02780001	1	スプールネジ"セット2	SPOOL SCREW SET 2	
91-8-1	150179002	2	スプールシャフトB	SPOOL SHAFT (B)	
91-8-2	028050246	2	ハ"ネサ"カ"ネ2-5	SPRING WASHER 2-5	
91-8-3	021500106	4	1シユナツト5	NUT 5	
91-8-4	050503006	1	ナヘ"コヒラサ"5X30	SCREW 5X30	
91-8-5	050501406	1	ナヘ"コヒラサ"5X14	SCREW 5X14	
91-9	S02782001	1	スプールネジ"セット3	SPOOL SCREW SET 3	
91-9-1	150179002	3	スプールシャフトB	SPOOL SHAFT (B)	
91-9-2	028050246	3	ハ"ネサ"カ"ネ2-5	SPRING WASHER 2-5	
91-9-3	021500106	5	1シユナツト5	NUT 5	
91-9-4	050503006	1	ナヘ"コヒラサ"5X30	SCREW 5X30	
91-9-5	050501406	1	ナヘ"コヒラサ"5X14	SCREW 5X14	
91-10	150180001	5	ウケサ"ラ	SPOOL STAND BASE	
91-11	150182000	5	スプールマット	SPOOL MAT	
91-12	126863001	5	スプールクッション	SPOOL CUSHION	
91-13	S02784009	1	ホルダー"ササエAセット	SPOOL HOLDER SUPPORT (A) SET	
91-13-1	150188009	1	スプールホルダー"ササエA	SPOOL HOLDER SUPPORT (A)	
91-13-2	062501006	1	ナヘ"コ5X10	SCREW 5X10	
91-13-3	021500106	1	1シユナツト5	NUT 5	
91-13-4	031452206	1	マルモク45X22	SCREW 45X22	
91-14	S02786002	1	スレット"ハンガ"ークミ2	THREAD HANGER ASSEMBLY 2	
91-15	S02788009	1	スレット"ハンガ"ークミ3	THREAD HANGER ASSEMBLY 3	
91-16	150145009	1	イトアンナイホルダ"ークミ	THREAD GUIDE HOLDER ASSEMBLY	
91-16-1	150185009	1	イトアンナイホルダ"ー	THREAD GUIDE HOLDER	
91-16-2	050503006	1	ナヘ"コヒラサ"5X30	SCREW 5X30	
91-16-3	021500106	1	1シユナツト5	NUT 5	
91-17	142999001	1	イトアンナイ5	THREAD GUIDE 5	
91-18	S04109001	1	イトアンナイササエホ"ウ	THREAD GUIDE SUPPORT BAR	
91-19	138843001	1	ササエホ"ウツキ"テ	JOINT	
91-20	014060632	2	アナトメ6X6クホ"ミ	SET SCREW 6X6	
< FOR CB2710, CB2720-0011, 0021, 0031, 0071, 007□ (□は1を除く) / 007□ - except 1 >					
1	S08715010	10	ミシンハリUYX128GAS	NEEDLE UYX128GAS	
< FOR CB2710-00T1, 00U1 >					
1	S08715014	10	ミシンハリUYX128GAS	NEEDLE UYX128GAS	
< FOR CB2710-00T2, 00U2 >					
1	S08715018	10	ミシンハリUYX128GAS	NEEDLE UYX128GAS	
< 特別注文部品 / OPTION PARTS >					
22	147893009	1	オサエアケ"フミイタ	TREADLE	
23	021400106	2	1シユナツト4	NUT 4	
24	062401406	2	ナヘ"コ4X14	SCREW 4X14	
25	116016001	2	ペ"タルトメ	PEDAL STOPPER	

CB2710, 2720-0021

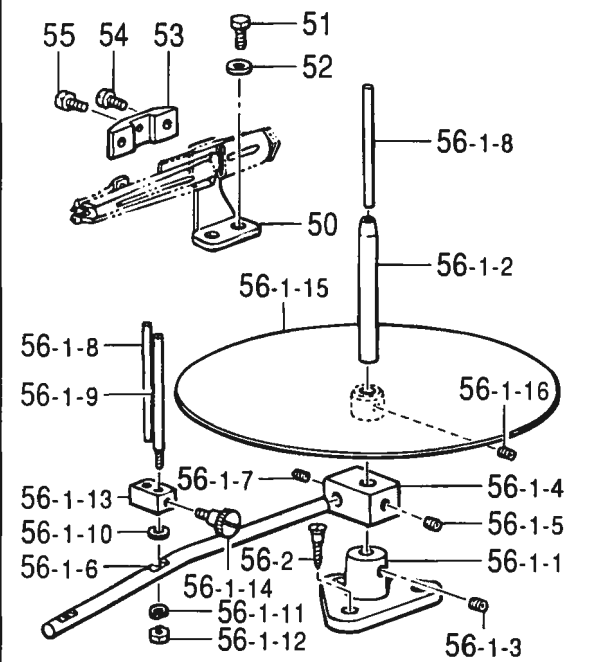

CB2710, 2720-0071

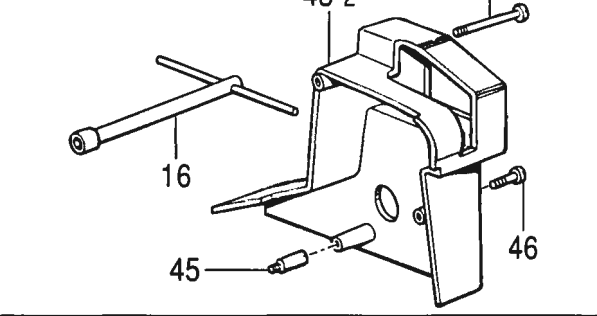

CB2710, 2720-0071, 007□ (□は1を除く)
/ 007□-except 1

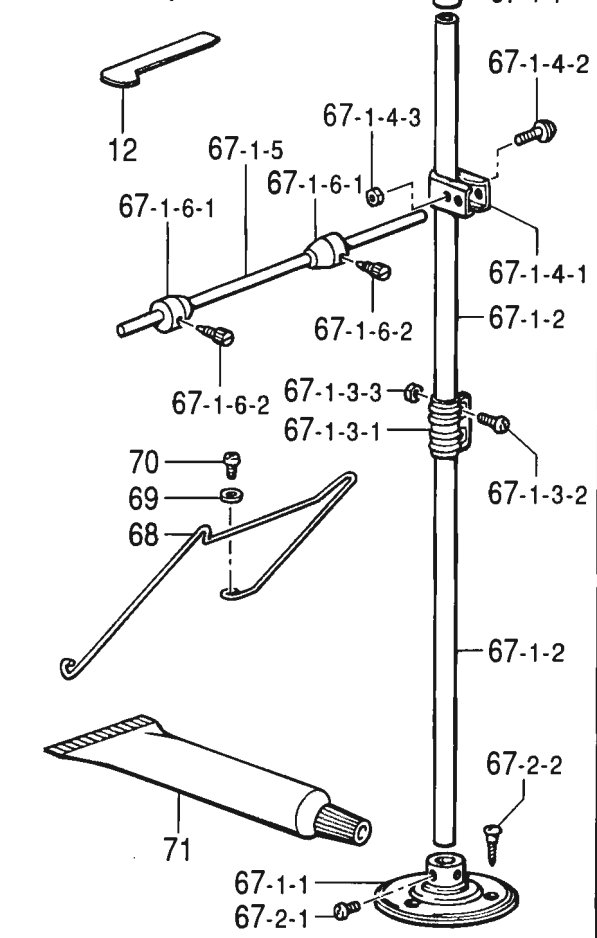

CB2710-0071, 007□, 00U1, 00U2,
CB2720-0071, 007□ (□は1を除く)
/ 007□-except 1

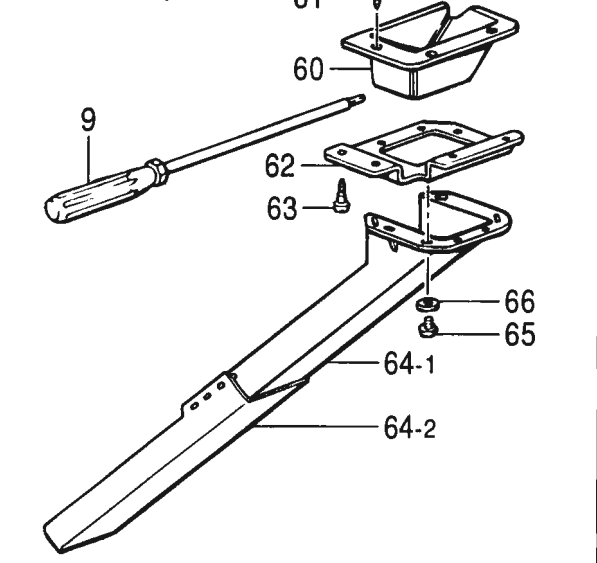

CB2710-0011, 0021, 0031,
007□, 00T1, 00T2, 00U1
CB2720-0011, 0021, 0031,
007□ (□は1を除く)
/ 007□-except 1

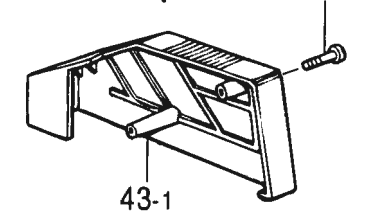

CB2710-00T1,
00T2

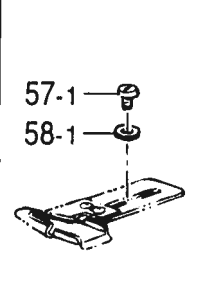

CB2710, 2720-0011

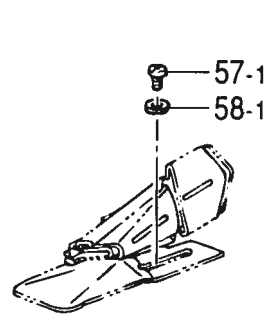

CB2710-00U1
00U2

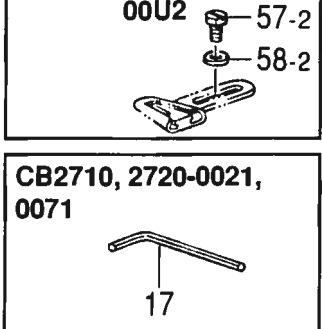

CB2710, 2720-0021,
0071

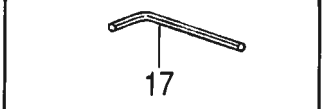

◎ 付属品の明細は変更することがあります。
◎ The details of included accessories are subject to change.

Z1. 付属品関係 / Accessories

REF NO	CODE	Q'TY	ヒンメイ	NAME OF PARTS	RMKS
< FOR CB2710-0011, 0021, 0031, 007 (は1を除く), 00T1, 00T2, 00U1, 00U2 / 007□ - except 1 >					
< FOR CB2720-0011, 0021, 0031, 007 (は1を除く) / 007 - except 1 >					
43-1	S09002009	1	ベルトカバー	BELT COVER	
44	102424004	2	シメネジ"4.37	SCREW 4.37	
< FOR CB2710-0011, 00T1, 00T2 >					
< FOR CB2720-0011 >					
57-1	062710812	2	ナヘ"コ476-32X8	SCREW 476X8	
58-1	116662003	2	サ"カ"ネ	WASHER	
< FOR CB2710-00U1, 00U2 >					
57-2	117363001	2	ボ"ルト4.76	BOLT 4.76	
58-2	146354001	2	サ"カ"ネ	WASHER	
< FOR CB2710, CB2720-0021 >					
50	S09004001	1	シ"ヨウキ"トリツケ"タイ	RULER SET BASE	
51	017711412	2	ボ"ルト4.76X14	BOLT 4.76X14	
52	116662003	2	サ"カ"ネ	WASHER	
53	S09005001	1	シ"ヨウキ"トリツケ"イ"タ	RULER SET PLATE	
54	107419002	2	シメネジ"4.37	SCREW 4.37	
55	146360002	1	ボ"ルト4.76X7	BOLT 4.76X7	
56	S09006009	1	テー"プ"カ"イト"ク"ミ"セ"ツ"ト	TAPE GUIDE ASSEMBLY SET	
56-1	S09007009	1	テー"プ"カ"イト"ク"ミ	TAPE GUIDE ASSEMBLY	
56-1-1	S09008009	1	シ"チ"ユ"ウ"ト"ダ"イ	TAPE BASE POST BRACKET	
56-1-2	S09009001	1	テー"プ"タ"イ"シ"チ"ユ"ウ	TAPE BASE POST	
56-1-3	014780622	1	ア"ナ"ト"メ"ネ"ジ"6.35"ク"ホ"ミ	SET SCREW 6.35	
56-1-4	S09010001	1	カ"イト"ホ"ウ"ホ"ル"タ"	GUIDE BAR HOLDER	
56-1-5	014780622	2	ア"ナ"ト"メ"ネ"ジ"6.35"ク"ホ"ミ	SET SCREW 6.35	
56-1-6	S09011001	1	テー"プ"カ"イト"ホ"ウ	TAPE GUIDE BAR	
56-1-7	014780622	2	ア"ナ"ト"メ"ネ"ジ"6.35"ク"ホ"ミ	SET SCREW 6.35	
56-1-8	S09012001	3	テー"プ"カ"イト"S	TAPE GUIDE (S)	
56-1-9	S09013001	2	テー"プ"カ"イト"L	TAPE GUIDE (L)	
56-1-10	025710232	2	ヒ"ラ"サ"カ"ネ"チ"ユ"ウ4.76	PLAIN WASHER 4.76	
56-1-11	028050242	2	ハ"ネ"サ"カ"ネ"2-5	SPRING WASHER 2-5	
56-1-12	021710102	2	ナ"ツ"ト1"シ"ユ4.76	NUT 4.76	
56-1-13	S09014101	2	テー"プ"カ"イト"サ"サ"エ	TAPE GUIDE SUPPORT	
56-1-14	115166001	4	タ"ン"ネ"ジ"4.37	STUD SCREW 4.37	
56-1-15	S09015009	1	テー"プ"タ"イ"ク"ミ	TAPE BASE ASSEMBLY	
56-1-16	014680422	1	ア"ナ"ト"メ"ネ"ジ"4.37"ク"ホ"ミ	SET SCREW 4.37	
56-2	100447001	3	サ"ラ"モ"ク"ネ"ジ"4.5X3.2	SCREW 4.5X3.2	
< FOR CB2710-0071, 007□ (□は1を除く), 00U1, 00U2 / 007□ - except 1 >					
< FOR CB2720-0071, 007□ (□は1を除く) / 007□ - except 1 >					
9	149173001	1	6"カ"ク"ホ"ウ"ネ"ジ"マ"ワ"シ"3	SCREW DRIVER 3	
60	S09018009	1	ダ"ス"タ"ー"ロ"ツ"プ"	DUSTER DROP	
61	031311302	3	マ"ル"モ"ク"ネ"ジ"3.1X13	SCREW 3.1X13	
62	S09019001	1	ダ"ス"タ"ー"シ"ユ"ー"ト"リ"ツ"ケ"イ"タ	DUSTER SHOOT SET PLATE	
63	031311302	4	マ"ル"モ"ク"ネ"ジ"3.1X13	SCREW 3.1X13	
64	183161209	1	ダ"ス"タ"ー"シ"ユ"ー"ト"ク"ミ	DUSTER SHOOT ASSEMBLY	
64-1	148431209	1	ダ"ス"タ"ー"シ"ユ"ー"ト"L	DUSTER SHOOT (L)	
64-2	148432009	1	ダ"ス"タ"ー"シ"ユ"ー"ト"S	DUSTER SHOOT (S)	
65	062680812	4	ナ"ヘ"コ437-40X8	SCREW 437X8	
66	025680232	4	ヒ"ラ"サ"カ"ネ"チ"ユ"ウ4.37	PLAIN WASHER 4.37	

CB2710, 2720-0021

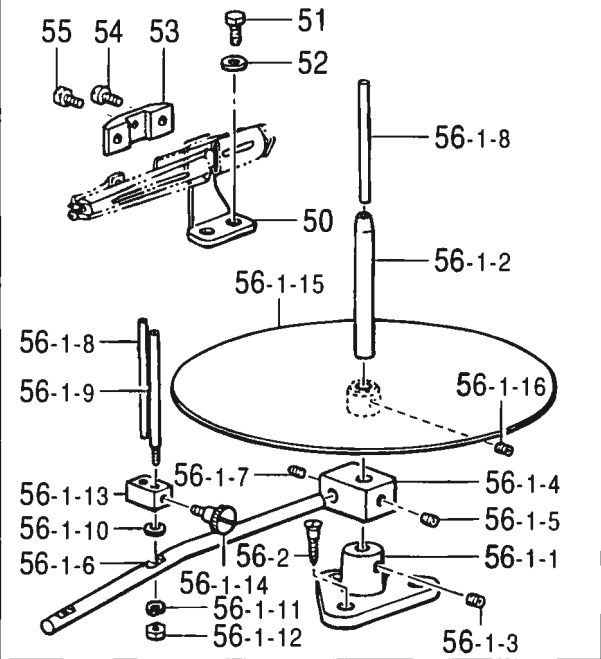

CB2710, 2720-0071

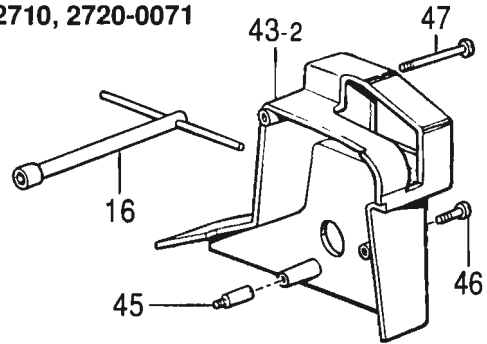

CB2710, 2720-0071, 007□ (□は1を除く)
/ 007□-except 1

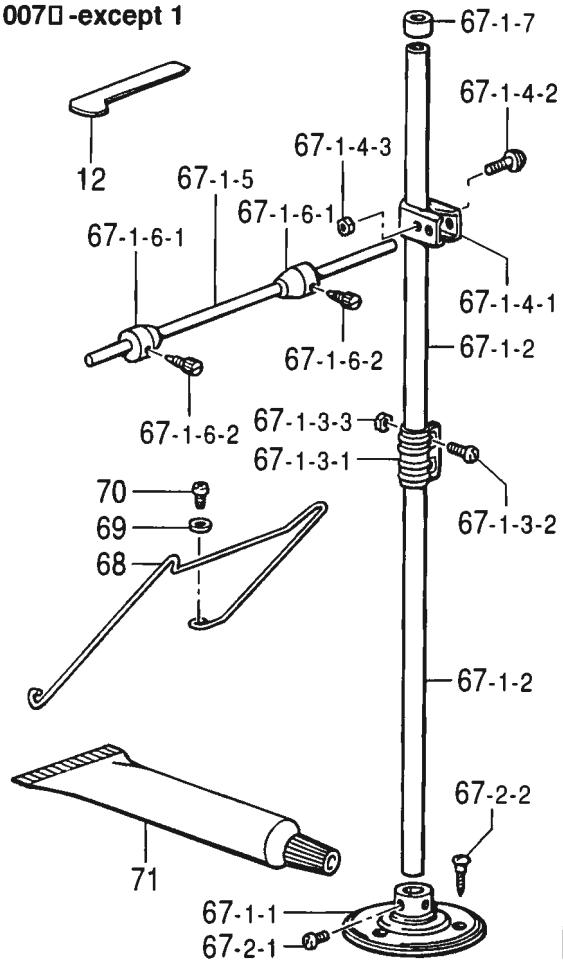

CB2710-0071, 007□, 00U1, 00U2,
CB2720-0071, 007□ (□は1を除く)
/ 007□-except 1

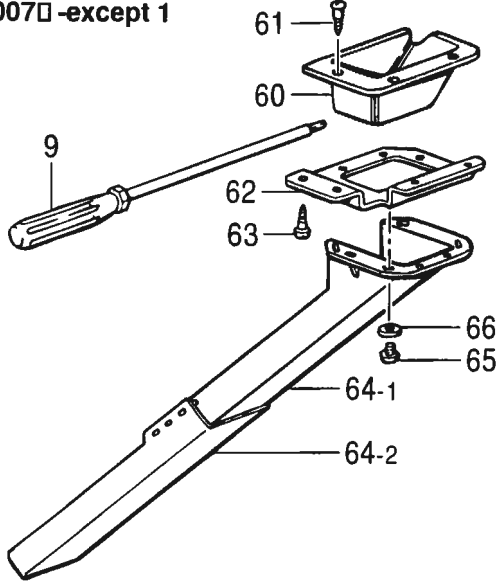

CB2710-0011, 0021, 0031,
007□, 00T1, 00T2, 00U1
CB2720-0011, 0021, 0031,
007□ (□は1を除く)
/ 007□-except 1

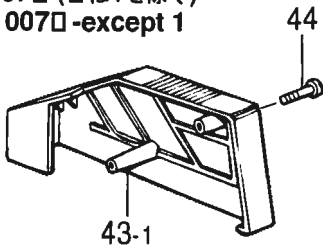

CB2710-00T1,
00T2

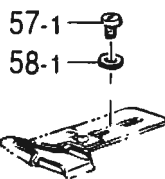

CB2710, 2720-0011

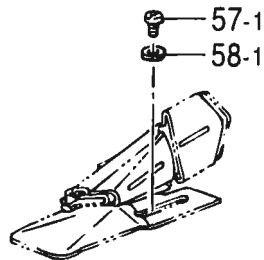

CB2710-00U1
00U2

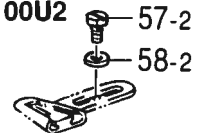

CB2710, 2720-0021,
0071



◎ 付属品の明細は変更することがあります。
◎ The details of included accessories are subject to change.

Z1. 付属品関係/Accessories

REF NO	CODE	Q'TY	品名	NAME OF PARTS	RMKS
< FOR CB2710, CB2720-0071 >					
16	140342001	1	ソケットレンチクミ	SOCKET WRENCH ASSEMBLY	
43-2	S09003009	1	ベルトカバー	BELT COVER	
45	148042001	2	ベルトカバー"スタット"	BELT COVER STUD	
46	102023005	2	シメネジ"4.37	SCREW 4.37	
47	141399001	1	ハンドル"リジク"	HANDLE SHAFT	
< FOR CB2710, CB2720-0071, 007 (□は1を除く) / 007 - except 1 >					
12	156309001	1	L"ガ"タネジ"マワシ	L-TIPE SCREW DRIVER	
67	150778103	1	T.R.Sクミ	TAPE REEL STAND SET	
67-1	150579009	1	テープ"リールスタンド"クミ	TAPE REEL STAND ASSEMBLY	
67-1-1	150189009	1	ブラケット	COTTON STAND BASE	
67-1-2	150172003	2	コラムパイプ	COLUMN PIPE	
67-1-3	150106003	1	コラムシヨイントクミ	COLUMN JOINT ASSEMBLY	
67-1-3-1	150173003	1	コラムシヨイント	COLUMN JOINT	
67-1-3-2	062501406	2	ナヘ"コ5X14	SCREW 5X14	
67-1-3-3	021500106	2	1シユナツト5	NUT 5	
67-1-4	150145009	1	イトアンナイホルダ"ークミ	THREAD GUIDE HOLDER ASSEMBLY	
67-1-4-1	150185009	1	イトアンナイホルダ"	THREAD GUIDE HOLDER	
67-1-4-2	050503006	1	ナヘ"コヒラサ"5X30	SCREW 5X30	
67-1-4-3	021500106	1	1シユナツト5	NUT 5	
67-1-5	150580001	1	ホ"ビ"ンアンナイホ"ウ	BOBBIN GUIDE BAR	
67-1-6	150581001	2	ホ"ビ"ンアンナイクミ	BOBBIN GUIDE ASSEMBLY	
67-1-6-1	150582001	2	ホ"ビ"ンアンナイ	BOBBIN GUIDE	
67-1-6-2	131226001	2	ハリトメネジ"3.57	NEEDLE SET SCREW 3.57	
67-1-7	150174000	1	コラムキャツプ	COLUMN CAP	
67-2	S02773001	1	ブラケットネジ"セット	COTTON STAND BASE SCREW SET	
67-2-1	062060806	2	ナヘ"コ6X8	SCREW 6X8	
67-2-2	031452206	3	マルモク45X22	SCREW 45X22	
68	S09020001	1	ゴムカ"イト"U	RUBBER GUIDE (U)	
69	148847001	2	サ"カ"ネ	WASHER	
70	062680812	2	ナヘ"コ437-40X8	SCREW 437X8	
71	S09021000	1	グ"リス	GREASE	
< FOR CB2710, CB2720-0021, 0071/TC1, TC3, ATC1, ATC2 >					
17	118064001	1	6カクホ"ウスハ"ナ4	HEXAGONAL WRENCH 4	

Z3 . 付属品関係 (オプション) / Accessories (Option)

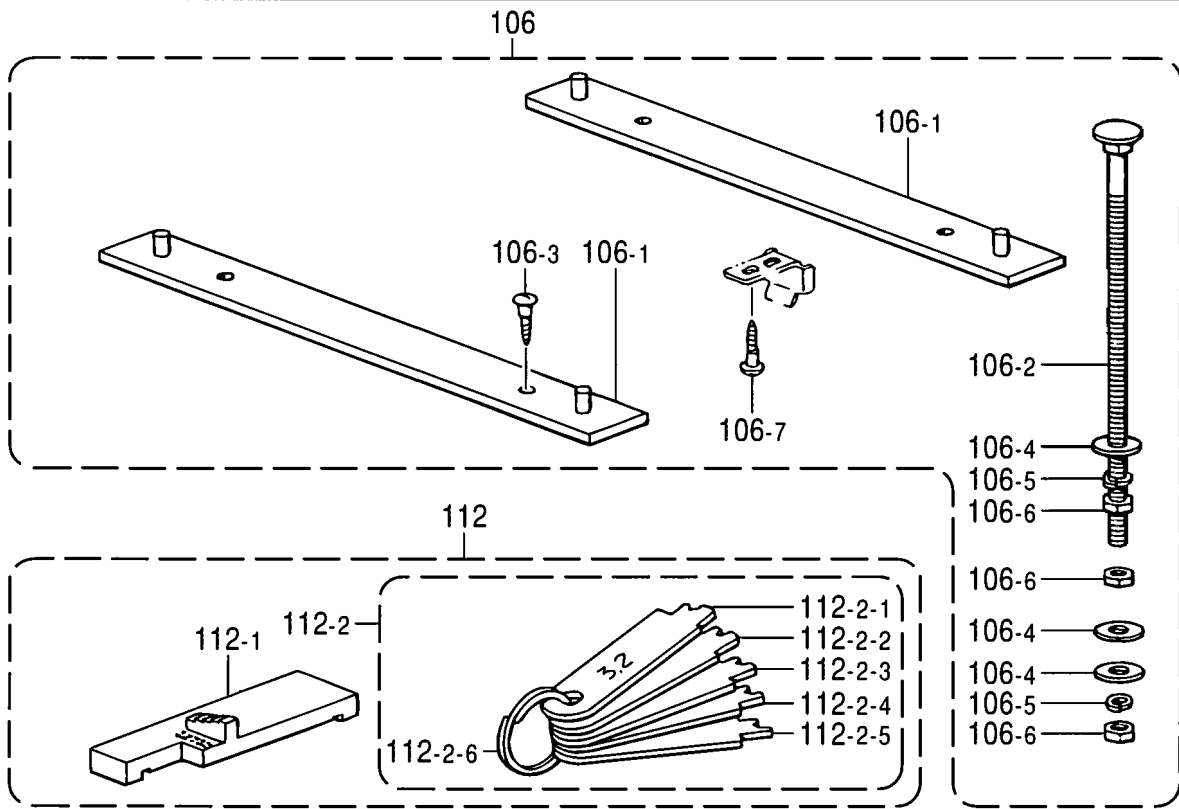

◎ 付属品の明細は変更することがあります。

◎ The details of included accessories are subject to change.

118-271-910

Z2. 付属品関係 (オプション)/Accessories (Option)

REF.NO.	CODE	Q'TY	ヒンメイ	NAME OF PARTS	RMKS
<オプション / OPTION >					
106	S11560001	1	フルサブ"マ-シ"セット	FULL SUBMRGED SET	
106-1	S11561001	2	トウフ"ウケイタ	HEAD SPOOL PLATE	
106-2	S11562001	4	カクネマルアタマホルト	BOLT	
106-3	100666002	4	マルモクネシ"5.5X20	SCREW 5.5X20	
106-4	025080336	12	ヒラサ"カ"ネタ"イ8	PLAIN WASHER 8	
106-5	028080242	8	ハ"ネサ"カ"ネ2-8	SPRING WASHER 2-8	
106-6	021080106	12	ナツト1シユ8	NUT 8	
106-7	032461606	2	+マルモクネシ"4.5X16	SCREW 4.5X16	
112	S13714001	1	テ"アイケ"-シ"セット	LOOPER TIMING GAUGE SET	
112-1	S13715001	1	テ"アイケ"-シ"フ"ロック	GAUGE BLOCK	
112-2	S13716001	1	テ"アイケ"-シ"イタクミ	GAUGE PLATE ASSEMBLY	
112-2-1	S13717001	1	テ"アイケ"-シ"イタ 3.2	GAUGE PLATE (3.2)	
112-2-2	S13718001	1	テ"アイケ"-シ"イタ 4.0	GAUGE PLATE (4.0)	
112-2-3	S13719001	1	テ"アイケ"-シ"イタ 4.8	GAUGE PLATE (4.8)	
112-2-4	S13720001	1	テ"アイケ"-シ"イタ 5.6	GAUGE PLATE (5.6)	
112-2-5	S13721001	1	テ"アイケ"-シ"イタ 6.4	GAUGE PLATE (6.4)	
112-2-6	S13722000	1	ニシ"ユウカン	HOLDER	

CODE	REF.NO.	PAGE
S00017001	A - 102	2
S00313009	A - 123	2
	A - 26	2
S00356001	K1 - 51	34
	K2 - 51	38
S00383001	K1 - 52	34
	K2 - 52	38
S00879001	C - 25	14
S01297001	E - 34	20
S01374001	C - 40-1-4	16
	C - 40-4-4	16
	N - 60-3	50
S01698001	L - 36	42
S01943001	Z1 - 6	62
S02606000	A - 5	2
S02769109	Z1 - 90	62
S02770109	Z1 - 91	64
S02773001	Z1 - 67-2	68
	Z1 - 90-2	62
	Z1 - 91-2	64
S02778002	Z1 - 90-6	62
	Z1 - 91-6	64
S02779009	Z1 - 91-7	64
S02780001	Z1 - 90-7	62
	Z1 - 91-8	64
S02782001	Z1 - 91-9	64
S02784009	Z1 - 91-13	64
S02786002	Z1 - 90-11	62
	Z1 - 91-14	64
S02788009	Z1 - 91-15	64
S02874001	D - 4-3	18
S03303001	P1 - 22	52
S03321001	L - 73	44
	P2 - 73	54
S03421001	J - 13	32
S03704001	B - 50	10
	E - 46	22
	H - 24	30
	M - 10	46
	N - 10	48
S04109001	Z1 - 90-14	62
	Z1 - 91-18	64
S04159000	P3 - 1-24	58
S05072000	P3 - 1-1-15	56
S06701000	Z1 - 19	62
S06704001	Z1 - 40	62
S08467000	E - 68	22
S08627001	A - 2	2
S08628000	A - 3	2
S08629009	A - 12	6
S08630201	A - 14	2
S08631000	A - 15	2
S08632009	A - 19	2
S08633101	A - 27	2
S08634101	A - 31-1	6
S08635101	A - 31-2	6
S08636101	A - 31-3	8
S08637001	A - 33-1	6
S08638001	A - 33-2	8
S08639000	A - 35	2
S08640001	A - 36-1	6
S08641001	A - 36-2	6
S08642001	A - 38	2
S08646100	A - 40	2
S08647001	A - 41-1	6
S08648001	A - 41-2	6
S08649001	A - 41-3	6

CODE	REF.NO.	PAGE
S08650001	A - 41-4	8
S08651001	A - 42	2
S08652000	A - 43	2
S08653001	A - 48	2
S08654001	A - 53	6
S08655001	A - 55	6
S08656001	A - 58	6
S08657001	A - 60	6
S08658001	A - 61	6
S08659001	A - 63	6
S08660001	A - 68	6
S08662001	A - 75-1	8
S08663001	A - 75-2	8
S08664001	A - 78	8
S08665001	A - 100-1	6
S08666001	A - 100-2	8
S08667001	A - 105	2
S08668001	A - 108	2
S08669001	A - 115	2
S08670000	A - 116	2
S08671101	A - 119	2
S08672000	A - 120	2
S08673000	A - 124	2
	A - 127	4
	A - 128	4
S08674000	A - 138	4
S08675000	A - 139	4
S08679109	B - 1	10
S08680009	B - 1-1	10
S08682001	B - 3	10
S08683000	B - 4	10
S08684101	B - 6	10
S08685101	B - 6-1	10
S08686001	B - 6-2	10
S08687001	B - 8	10
S08688001	B - 9	10
S08689001	B - 11	10
S08692101	B - 16	10
S08693001	B - 16-1	10
S08694001	B - 16-2	10
S08695001	B - 16-4	10
S08696000	B - 23	10
S08697000	B - 24	10
S08698001	B - 25	10
S08715010	B - 31	12
	Z1 - 1	64
S08715014	B - 31	12
	Z1 - 1	64
S08715018	B - 31	12
	Z1 - 1	64
S08716201	B - 35	10
S08750001	B - 42	10
S08751001	B - 44	10
S08752001	B - 46	10
S08753000	B - 48	10
	M - 8	46
	N - 8	48
S08754000	B - 49	10
	H - 23	30
	M - 9	46
	N - 9	48
S08755001	B - 51	10
S08756001	B - 53	10
S08757001	B - 55	10
S08758009	D - 1	18
S08760009	D - 1-1	18

CODE	REF.NO.	PAGE
S08761000	D - 3	18
S08762101	D - 4	18
S08764100	D - 4-1	18
S08765000	D - 4-2	18
S08766000	D - 6	18
S08767001	C - 1	14
S08768001	C - 2	14
S08769001	C - 6	14
S08770000	C - 12	14
	H - 7	30
	K1 - 49	34
	K2 - 49	38
S08771001	C - 14	14
S08774001	C - 18	14
S08775000	C - 28	14
S08776001	C - 30	14
S08777001	C - 31	14
S08778000	C - 32	14
S08782101	C - 40-1-1	16
	C - 40-4-1	16
S08783101	C - 40-1-3	16
S08784001	C - 40-1-6	16
S08785001	C - 40-1-8	16
	C - 40-4-7	16
S08802101	C - 40-2-1	16
S08806101	C - 40-2-2	16
	C - 40-3-2	16
	C - 40-5-2	18
	C - 40-6-2	18
S08807101	C - 40-2-4	16
	C - 40-3-4	16
	C - 40-5-4	18
	C - 40-6-4	18
S08808001	C - 40-2-7	16
	C - 40-3-7	16
	C - 40-5-7	18
	C - 40-6-7	18
S08809001	C - 40-2-9	16
	C - 40-3-9	16
	C - 40-5-9	18
	C - 40-6-9	18
S08810001	C - 40-2-10	16
	C - 40-3-10	16
S08811101	C - 40-2-12-2	16
S08812001	C - 40-2-14	16
	C - 40-3-18	16
	C - 40-5-12	18
	C - 40-6-12	18
S08817101	C - 40-2-12-1	16
S08842101	C - 40-3-1	16
S08844101	C - 40-3-12	16
S08845101	C - 40-3-14	16
S08846101	C - 40-3-16	16
S08864101	C - 40-4-3	16
S08865101	C - 40-4-5	16
S08870001	E - 8	20
S08871001	E - 10	20
S08872001	E - 20	20
S08873001	E - 20-1	20
S08876000	E - 36	20
S08877001	E - 44	20
S08878001	E - 52	22
S08879001	E - 55	22
S08880001	E - 56	22
S08881101	E - 62	22
S08889001	F - 1	24
S08890101	F - 1-1	24

CODE	REF.NO.	PAGE
S08891001	F - 5	24
S08892001	F - 8	24
S08895001	F - 10-1	24
S08895002	F - 10-2	24
S08895003	F - 10-3	24
S08896101	F - 11	24
S08897001	F - 11-1	24
S08898000	F - 13	24
S08899001	F - 14	24
S08900000	F - 16	24
S08903000	F - 17	24
S08904000	F - 20	24
S08906001	H - 1	30
S08910001	H - 5	30
S08911000	H - 8	30
S08912001	H - 10	30
S08913001	H - 12-1	30
S08914001	H - 16	30
S08915001	H - 19	30
S08916001	H - 21-1	30
S08917000	H - 22	30
S08918001	H - 25	30
S08919001	H - 28	30
S08920001	H - 29	30
S08921101	H - 31	30
S08923101	J - 1	32
S08926101	J - 4	32
S08927001	J - 10	32
S08928001	J - 15	32
S08929001	J - 15-1	32
S08930001	J - 15-2	32
S08931001	J - 19	32
S08932000	J - 20	32
S08933001	J - 24	32
S08934001	J - 26	32
S08935001	G - 1	26
S08936101	G - 3	26
S08937001	G - 3-4	26
S08939000	G - 3-7	26
S08940000	G - 6	26
S08943000	G - 12	26
S08944001	G - 13	26
S08945001	G - 16	26
S08946000	G - 18	26
S08947001	G - 19	26
S08948001	G - 22	26
S08951001	G - 26	26
S08953001	G - 37	26
S08955001	G - 32	26
S08956000	G - 34	26
S08957001	G - 35	26
S08958001	G - 40	26
S08961101	K1 - 1	34
	K2 - 1	38
S08962109	K1 - 6	34
	K2 - 6	38
S08963001	K1 - 10	34
	K2 - 10	38
S08964001	K1 - 11	34
	K2 - 11	38
S08965009	K1 - 27	34
	K2 - 27	38
S08966001	K1 - 28	34
	K2 - 28	38
S08967001	F - 19	24
	K1 - 29	34
	K2 - 29	38

CODE	REF.NO.	PAGE
S08968001	K1 - 31	34
	K2 - 31	38
S08969101	K1 - 40	34
	K2 - 40	38
S08970001	K1 - 91	36
	K2 - 43	38
	K2 - 91	40
S08971101	K1 - 45	34
	K2 - 45	38
S08976001	K1 - 50	34
	K2 - 50	38
S08977001	K1 - 54	34
	K2 - 54	38
S08978001	K1 - 57	34
	K2 - 57	38
S08979001	K2 - 60	38
S08980001	K2 - 61	40
S08981001	K1 - 68	34
	K2 - 68	40
S08982001	K1 - 70	34
	K2 - 70	40
S08983001	K1 - 72	34
	K2 - 72	40
S08984001	K1 - 73	34
	K2 - 73	40
S08985001	K2 - 78	40
S08986001	K2 - 80	40
S08987001	K1 - 104	36
	K2 - 104	40
	K2 - 81	40
S08988001	K2 - 85	40
S08989001	K1 - 87	36
	K2 - 87	40
S08992001	K1 - 102	36
	K2 - 102	40
S08993101	K1 - 108	36
	K2 - 108	40
S08994001	K1 - 111	36
	K2 - 111	40
S08995001	K1 - 116	36
	K2 - 116	40
S09001001	Z1 - 36	62
S09002009	Z1 - 43-1	66
S09003009	Z1 - 43-2	68
S09004001	Z1 - 50	66
S09005001	Z1 - 53	66
S09006009	Z1 - 56	66
S09007009	Z1 - 56-1	66
S09008009	P3 - 1-8	56
	Z1 - 56-1-1	66
S09009001	Z1 - 56-1-2	66
S09010001	Z1 - 56-1-4	66
S09011001	Z1 - 56-1-6	66
S09012001	Z1 - 56-1-8	66
S09013001	Z1 - 56-1-9	66
S09014101	Z1 - 56-1-13	66
S09015009	Z1 - 56-1-15	66
S09018009	Z1 - 60	66
S09019001	Z1 - 62	66
S09020001	Z1 - 68	68
S09021000	Z1 - 71	68
S09022009	N - 83	50
S09023101	L - 1	42
S09024001	L - 3	42
S09025001	L - 4	42
S09026001	L - 20	42

CODE	REF.NO.	PAGE
S09026001	L - 5	42
S09027001	L - 7	42
S09028001	L - 10	42
S09032001	L - 12	42
S09033001	L - 15	42
S09034001	L - 17	42
S09035001	L - 19	42
S09036001	L - 11	42
S09037001	L - 22	42
S09039001	L - 22-2	42
S09040001	L - 24	42
S09041001	L - 26	42
S09042000	L - 30	42
	P2 - 30	54
S09043000	L - 31	42
	N - 59	48
	P2 - 31	54
S09044001	L - 34-1	42
S09045001	L - 35	42
S09046001	L - 37	42
	P2 - 37	54
S09047001	L - 39	42
	P2 - 39	54
S09049000	L - 39-1	42
	P2 - 39-1	54
S09050001	L - 41	42
	P2 - 41	54
S09051001	L - 43	42
	P2 - 43	54
S09052001	L - 44	42
	P2 - 44	54
S09053001	L - 47	42
	P2 - 47	54
S09054001	L - 48	42
	P2 - 48	54
S09055001	L - 51	42
	M - 30	46
	P2 - 51	54
S09056001	L - 54	44
	P2 - 54	54
S09057001	L - 57	44
	P2 - 57	54
S09058001	L - 61	44
	P2 - 61	54
S09059001	L - 62	44
	P2 - 62	54
S09060001	L - 64	44
	P2 - 64	54
S09061001	L - 68	44
	P2 - 68	54
S09062001	L - 70	44
	P2 - 70	54
S09065001	L - 71	44
	P2 - 71	54
S09067001	M - 3	46
	N - 3	48
S09069001	M - 3-2	46
	N - 3-2	48
S09070001	M - 6	46
	N - 6	48
S09071001	M - 11	46
S09072101	M - 15	46
S09073101	M - 17	46
S09075001	M - 21	46
S09076001	M - 22	46
S09077001	M - 24	46
S09079000	M - 26	46

CODE	REF.NO.	PAGE
S09080001	M - 28	46
S09081001	M - 34	46
S09082001	N - 17	48
S09084000	N - 17-1	48
S09085000	N - 17-2	48
S09086001	N - 20	48
S09087001	N - 22	48
	N - 26	48
S09088001	N - 24	48
S09089001	N - 28	48
S09090001	N - 30	48
S09091001	N - 34	48
S09092001	N - 35	48
S09093001	N - 37	48
S09094001	N - 38	48
S09095001	N - 40	48
S09096001	N - 41	48
S09097001	N - 44	48
S09099001	N - 45	48
S09101001	N - 46	48
S09102001	N - 47	48
S09103001	N - 49	48
S09104001	N - 51	48
S09105001	N - 58	48
S09106101	N - 60	50
S09107101	N - 60-1	50
S09110001	N - 62	50
S09111001	N - 64	50
S09112001	N - 67	50
S09113001	N - 69	50
S09114001	N - 75	50
S09115001	N - 76	50
S09116001	N - 79	50
S09117001	N - 81	50
S09118001	N - 90	50
S09119001	N - 91	50
S09120001	B - 16-3	10
S09121001	B - 41	10
S09123101	A - 34	2
S09124001	B - 38	10
S09125001	G - 45	26
S09193001	A - 75	8
S09251001	H - 31-1	30
S09260001	P2- 90	54
S09316000	G - 42	26
S09319001	A - 73	6
S09320001	A - 70	6
S09396001	A - 66	6
S09500001	N - 85	50
S09754000	P3- 1-1-5	56
S10243000	P4- 4-6	60
S10656001	J - 1-1	32
S10657001	K1 - 45-1	34
	K2 - 45-1	38
S10856001	P1 - 24	52
S10942000	P3 - 1-1-22	56
S10944000	P3 - 1-1-16	56
S11445001	N - 60-2	50
S11560001	Z2 - 106	70
S11561001	Z2 - 106-1	70
S11562001	Z2 - 106-2	70
S11588001	H - 21-2	30
S11589000	H - 33	30
S11633000	P3 - 1-15	56
S11634000	P3 - 1-16	58
S11635000	P3 - 1-17	58
S12683001	H - 12-2	30

CODE	REF.NO.	PAGE
S13103009	N - 65	50
S13351009	P4 - 4-1-1	60
S13354001	P4 - 4-1-13	60
S13355001	P4 - 4-1-2	60
S13385001	B - 39	10
S13714001	Z2 - 112	70
S13715001	Z2 - 112-1	70
S13716001	Z2 - 112-2	70
S13717001	Z2 - 112-2-1	70
S13718001	Z2 - 112-2-2	70
S13719001	Z2 - 112-2-3	70
S13720001	Z2 - 112-2-4	70
S13721001	Z2 - 112-2-5	70
S13722000	Z2 - 112-2-6	70
S13809001	J - 6	32
S14094001	M - 1	46
	N - 1	48
S16244001	C - 40-3-17	16
S16249001	E - 75	22
S16498001	E - 1-1	20
S17477001	A - 41-5	8
S17486001	C - 40-5-1	18
S17488001	C - 40-5-10	18
	C - 40-6-10	18
S17491001	C - 40-6-1	18
S17493001	C - 40-6-13	18
S18354000	P3 - 1-1-27	56
S18530001	K1 - 94	36
	K2 - 94	40
S18532001	K1 - 96	36
	K2 - 96	40
S18534001	K1 - 98	36
	K2 - 98	40
S18535001	K1 - 100	36
	K2 - 100	40
S18800009	P2 - 80	54
S18801009	P2 - 82	54
S18803009	P2 - 84	54
S18805001	P2 - 34-2	54
S18806001	P1 - 27	52
S18808009	P1 - 20	52
S18810001	P1 - 21	52
S18813009	P3 - 1-1-1	56
S18814001	P3 - 1-1-4	56
S18819000	P3 - 1-1-17	56
S18820000	P3 - 1-1-18	56
S18821000	P3 - 1-1-23	56
S18822000	P3 - 1-1-24	56
S18823000	P3 - 1-1-25	56
S18824000	P3 - 1-1-26	56
S18826001	P3 - 1-2	56
S18827009	P3 - 1-7	56
S18828009	P3 - 1-7-1	56
S18829009	P3 - 1-7-2	56
S18830000	P3 - 1-7-5	56
S18831000	P3 - 1-7-7	56
S18832000	P3 - 1-7-9	56
S18833000	P3 - 1-7-10	56
S18834000	P3 - 1-7-11	56
S18835000	P3 - 1-7-12	56
S18836000	P3 - 1-7-13	56
S18837000	P3 - 1-7-14	56
S18838000	P3 - 1-11	56
S18839000	P3 - 1-12	56
S18840000	P3 - 1-18	58
S18842000	P3 - 1-21	58
S18852001	P4 - 2	60

CODE	REF.NO.	PAGE
S18853001	P4 - 2-1	60
S18854001	P4 - 3	60
S18855000	P4 - 3-1	60
S18922001	P4 - 4-1	60
S18923001	P4 - 4-1-15	60
S18928001	P4 - 4-1-5	60
S18946001	P4 - 4-4	60
S18962001	P4 - 4	60
S19842000	P3 - 1-1-28	56
S19843001	P4 - 4-9	60
S19855026	A - 154	4
S19869001	K1 - 26	34
	K2 - 26	38
S19869002	K1 - 23	34
	K2 - 23	38
S19869003	K1 - 21	34
	K2 - 21	38
	K2 - 25	38
S19869004	K1 - 22	34
	K2 - 22	38
S20248000	P2 - 88	54
S20249000	P2 - 88-1	54
S20250000	P2 - 88-2	54
S20251000	P2 - 88-3	54
U03292001	P3 - 1-7-6	56
	P3 - 1-7-8	56
U20018001	P3 - 1-1-11	56
U22701001	P3 - 1-1-19	56
002302203	P3 - 1-1-6	56
008300604	P3 - 1-7-3	56
014060632	Z1 - 90-16	62
	Z1 - 91-20	64
014680422	A - 62	6
	A - 65	6
	A - 67	6
	B - 54	10
	H - 13	30
	J - 23	32
	K1 - 117	36
	K1 - 5	34
	K1 - 71	34
	K2 - 117	40
	K2 - 5	38
	K2 - 71	40
	L - 45	42
	L - 49	42
	L - 69	44
	L - 72	44
	M - 18	46
	M - 20	46
	N - 29	48
	N - 53	48
	N - 61	50
	P2 - 45	54
	P2 - 49	54
	P2 - 69	54
	P2 - 72	54
	Z1 - 56-1-16	66
014680622	B - 43	10
	B - 45	10
	G - 17	26
	H - 17	30
	J - 1-1-1	32
	M - 1-1	46
	N - 1-1	48
014710522	N - 65-1	50
	P2 - 89	54

CODE	REF.NO.	PAGE
014760622	B - 15	10
	B - 18	10
	C - 26	14
014770622	B - 13	10
	B - 2	10
	B - 5	10
	B - 50-1	10
	B - 7	10
	E - 46-1	22
	F - 12	24
	F - 15	24
	F - 9	24
	G - 2	26
	H - 20	30
	H - 24-1	30
	J - 13-1	32
	J - 16	32
	K1 - 45-1-1	34
	K2 - 45-1-1	38
	M - 10-1	46
	N - 10-1	48
014780622	E - 43	20
	F - 2	24
	L - 27	42
	P3 - 1-9	56
	Z1 - 56-1-3	66
	Z1 - 56-1-5	66
	Z1 - 56-1-7	66
017711412	Z1 - 51	66
017781412	E - 65	22
	G - 4	26
018060822	A - 13	6
018061222	L - 38	42
	N - 19	48
	P2 - 38	54
018061422	L - 29	42
	M - 16	46
018062222	P2 - 81	54
018081622	A - 140	4
018400632	N - 77	50
018501022	P4 - 2-2	60
018680822	K1 - 97	36
	K2 - 97	40
018681022	B - 36	10
	B - 52	10
	N - 25	48
	N - 36	48
	N - 92	50
	P2 - 83	54
018771432	C - 10	14
	E - 48	22
	E - 52-2	22
	E - 55-1	22
	E - 7	20
	F - 7	24
	H - 11	30
	H - 2	30
	J - 5	32
	K1 - 47	34
	K1 - 55	34
	K2 - 47	38
	K2 - 55	38
	M - 12	46
	M - 4	46
	N - 21	48
	N - 4	48
021080106	Z1 - 34	62

CODE	REF.NO.	PAGE
021080106	Z2 - 106-6	70
021300105	P3 - 1-1-20	56
	P3 - 1-1-7	56
021400106	Z1 23	62
021400164	P3 - 1-1-13	56
021500106	Z1 - 67-1-3-3	68
	Z1 - 67-1-4-3	68
	Z1 - 90-12-3	62
	Z1 - 90-4-3	62
	Z1 - 90-7-3	62
	Z1 - 91-13-3	64
	Z1 - 91-16-3	64
	Z1 - 91-4-3	64
	Z1 - 91-8-3	64
	Z1 - 91-9-3	64
021500205	P3 - 1-4	56
021660102	C - 40-2-8	16
	C - 40-3-8	16
	C - 40-5-8	18
	C - 40-6-8	18
021710102	Z1 - 56-1-12	66
025030135	P3 - 1-1-21	56
	P3 - 1-1-8	56
025040233	P3 - 1-1-12	56
025050233	P3 - 1-5	56
025080236	Z1 - 32	62
025080336	Z2 - 106-4	70
025350332	G - 3-2	26
	P4 - 4-1-3	60
	P4 - 4-2	60
025630232	L - 59	44
	P2 - 59	54
025680232	Z1 - 66	66
025710232	A - 85	6
	Z1 - 56-1-10	66
025770232	E - 64	22
	L - 52	42
	P2 - 52	54
028030245	P3 - 1-1-9	56
028050242	P4 - 2-3	60
	Z1 - 56-1-11	66
028050246	Z1 - 90-7-2	62
	Z1 - 91-8-2	64
	Z1 - 91-9-2	64
028060242	L - 23	42
028080242	Z1 - 33	62
	Z2 - 106-5	70
031311302	Z1 - 61	66
	Z1 - 63	66
031411304	P3 - 1-23	58
031452206	Z1 - 67-2-2	68
	Z1 - 90-2-2	62
	Z1 - 91-13-4	64
	Z1 - 91-2-2	64
031482504	P3 - 1-6	56
032461606	Z2 - 106-7	70
034422006	P4 - 3-2	60
034422503	P3 - 1-27	58
047140842	N - 44-1	48
	N - 45-1	48
047150850	M - 17-1	46
047200642	D - 1-2	18
047201640	D - 7-1	18
047402042	N - 17-3	48
047502242	E - 61	22
048015346	C - 40-2-5	16
	C - 40-3-5	16

CODE	REF.NO.	PAGE
048015346	C - 40-5-5	18
	C - 40-6-5	18
048020342	C - 40-1-5	16
048030342	L - 63	44
	P2 - 63	54
048040342	E - 9	20
	P4 - 4-1-14	60
048050342	M - 27	46
	M - 33	46
048060342	P3 - 1-25-6-2	58
048150143	E - 1-12	20
050501406	Z1 - 90-7-5	62
	Z1 - 91-8-5	64
	Z1 - 91-9-5	64
050503006	Z1 - 67-1-4-2	68
	Z1 - 90-12-2	62
	Z1 - 90-7-4	62
	Z1 - 91-16-2	64
	Z1 - 91-8-4	64
	Z1 - 91-9-4	64
060630312	B - 56	10
060630412	C - 40-2-11	16
	C - 40-3-11	16
	C - 40-5-11	18
	L - 60	44
	P2 - 60	54
060660416	K1 - 112	36
	K2 - 112	40
060680512	A - 59	6
	E - 76	22
060680712	A - 106	2
	C - 3	14
	K1 - 41	34
	K1 - 95	36
	K2 - 41	38
	K2 - 62	40
	K2 - 79	40
	K2 - 95	40
	P2 - 85	54
	Z1 - 37	62
060681612	A - 45	2
062060806	Z1 - 67-2-1	68
	Z1 - 90-2-1	62
	Z1 - 91-2-1	64
062401406	Z1 - 24	62
062501006	Z1 - 91-13-2	64
062501406	Z1 - 67-1-3-2	68
	Z1 - 90-4-2	62
	Z1 - 91-4-2	64
062630412	K1 - 88	36
	K2 - 88	40
062630612	H - 30	30
062630812	P4 - 4-1-6	60
062660412	H - 4	30
062660512	C - 40-1-7	16
	C - 40-4-6	16
	E - 1-8	20
	M - 35	46
	N - 60-4	50
062660712	E - 52-1	22
062670412	C - 40-3-15	16
	P4 - 4-1-11	60
062670512	K1 - 109	36
	K1 - 99	36
	K2 - 109	40
	K2 - 99	40
062670612	A - 136	4

CODE	REF.NO.	PAGE	
062670612	B - 21	10	
	G - 10	26	
	G - 14	26	
	G - 20	26	
	G - 23	26	
	G - 41	26	
	G - 51	28	
	G - 8	26	
	K1 - 69	34	
	K2 - 69	40	
	L - 21	42	
	L - 6	42	
	N - 84	50	
	P4 - 4-3	60	
	062670712	N - 39	48
		P4 - 4-1-4	60
	062670812	A - 69	6
		C - 33	14
		D - 5	18
	062671012	D - 8	18
		E - 19	20
F - 25		24	
G - 3-3		26	
G - 3-9		26	
062680612		A - 47	2
		F - 4	24
K1 - 92		36	
K2 - 44		38	
K2 - 92		40	
N - 82	50		
062680712	P1 - 26	52	
	P2 - 87	54	
	P3 - 1-20	58	
	P4 - 4-5	60	
062680812	P4 - 4-7	60	
	A - 101	2	
062681012	A - 28	2	
	B - 37	10	
	G - 33	26	
	G - 43	26	
	K1 - 2	34	
	K1 - 74	36	
	K2 - 2	38	
	K2 - 74	40	
	N - 48	48	
	Z1 - 65	66	
	Z1 - 70	68	
	A - 111	2	
	A - 4	2	
	E - 31	20	
	E - 35	20	
	J - 27	32	
	K1 - 58	34	
	K1 - 7	34	
	K2 - 58	38	
	K2 - 7	38	
L - 56	44		
M - 23	46		
P2 - 56	54		
P4 - 4-1-16	60		
062681212	K1 - 32	34	
	K2 - 32	38	
	P1 - 23	52	
062681412	A - 51	6	
	C - 29	14	
	J - 25	32	
	L - 2	42	

CODE	REF.NO.	PAGE	
062681612	A - 16	2	
062710612	A - 56	6	
062710812	A - 54	6	
	Z1 - 57-1	66	
062711012	B - 10	10	
	L - 74	44	
	P2 - 74	54	
	N - 43	48	
062712012	N - 43	48	
062780812	G - 46	26	
072600000	F - 22	24	
076300800	L - 10-2	42	
076304850	P1 - 27-1	52	
081003670	E - 12	20	
081007670	J - 21	32	
081014670	A - 6	2	
081032870	F - 18	24	
081044070	G - 36	26	
100025002	E - 1-17	20	
100032004	A - 32	2	
100064005	B - 19	10	
	C - 40-1-2	16	
	C - 40-2-3	16	
	C - 40-3-3	16	
	C - 40-4-2	16	
	C - 40-5-3	18	
	C - 40-6-3	18	
	L - 53	42	
	P2 - 53	54	
	E - 5	20	
100251001	N - 68	50	
100257010	E - 59	22	
100294002	M - 3-4	46	
100366001	N - 3-4	48	
100447001	P3 - 1-10	56	
100463001	Z1 - 56-2	66	
	P3 - 1-25-3	58	
100645003	A - 72	6	
	E - 30	20	
100666002	G - 44	26	
	K1 - 59	34	
	Z2 - 106-3	70	
	101118001	P3 - 1-14	56
	101482001	J - 3	32
	101572101	Z1 - 4	62
	101706001	A - 104-1	2
		E - 40	20
	102023005	G - 3-6-1	26
		Z1 - 46	68
102424004	Z1 - 44	66	
102630001	B - 22	10	
102707002	C - 34	14	
102716004	M - 32	46	
	N - 33	48	
102843004	A - 20	2	
103810002	L - 22-1	42	
	L - 67	44	
104449009	P2 - 67	54	
	A - 21	2	
104450109	A - 130	4	
	A - 22	2	
104464001	B - 12	10	
	K1 - 110	36	
105161004	K1 - 115	36	
	K2 - 110	40	
	K2 - 115	40	

CODE	REF.NO.	PAGE
105234003	A - 112	2
	A - 52	6
105343001	Z1 - 13	62
106128004	L - 16	42
	L - 25	42
107153001	B - 17	10
107231002	N - 70	50
	N - 80	50
107272002	E - 45	20
107407003	A - 109	2
	A - 117	2
	A - 121	2
107419002	A - 71	6
	Z1 - 54	66
107453001	L - 8	42
107752000	N - 18	48
108520009	A - 25	2
108960002	M - 14	46
109203001	A - 142	4
	E - 60	22
109763002	L - 46	42
	P2 - 46	54
110087001	P3 - 1-25-5	58
110161006	H - 27	30
	J - 8	32
110197001	J - 22	32
	L - 32	42
	P2 - 32	54
110243001	M - 31	46
	N - 32	48
110641002	A - 141	4
110704001	H - 3	30
110735002	N - 78	50
110778002	L - 9	42
110793001	C - 7	14
110813001	K1 - 12	34
	K2 - 12	38
110820101	L - 50	42
	P2 - 50	54
110832009	K1 - 14	34
	K2 - 14	38
111105002	C - 40-6-11	18
112299001	K1 - 76	36
	K2 - 76	40
112300001	K1 - 75	36
	K2 - 75	40
112301001	K1 - 77	36
	K2 - 77	40
112348001	G - 28	26
	G - 31	26
	G - 39	26
112351001	G - 27	26
112359001	G - 30	26
	G - 38	26
112364001	G - 24	26
112467002	G - 3-12	26
112743001	G - 7	26
112751003	N - 52	48
112754001	G - 53	28
113431002	E - 50	22
	N - 42	48
114294001	F - 21	24
114967001	P3 - 1-25-4	58
114985001	A - 46	2
115166001	A - 74	6

CODE	REF.NO.	PAGE
115166001	Z1 - 56-1-14	66
116016001	Z1 - 25	62
116662003	Z1 - 52	66
	Z1 - 58-1	66
116662004	L - 13	42
117006001	N - 23	48
	N - 27	48
117363001	Z1 - 57-2	66
117466000	Z1 - 18	62
117516001	A - 118	2
	A - 122	2
	E - 1-16	20
117517003	A - 18	2
117934009	Z1 - 17	68
118064001	K1 - 30	34
118718001	K2 - 30	38
	L - 28	42
118735002	G - 11	26
118770001	Z1 - 5	62
118837001	B - 14	10
118853001	A - 64	6
120068001	H - 31-1-1	30
120990001	A - 75-3	8
122771002	Z1 - 92	62
122991001	A - 37	2
123185001	A - 39	2
	A - 79	8
126863001	Z1 - 90-10	62
	Z1 - 91-12	64
131226001	Z1 - 67-1-6-2	68
138843001	Z1 - 90-15	62
	Z1 - 91-19	64
140063001	A - 107	2
140065001	A - 126	6
140165001	E - 1-3	20
140176001	E - 1-15	20
140205001	E - 47	22
140207001	E - 21	20
140208001	E - 22	20
	E - 27	20
140209001	E - 23	20
140210001	E - 24	20
140217001	E - 28	20
140232001	M - 3-3	46
	N - 3-3	48
140313001	H - 31-2	30
140326009	E - 4	20
140327001	E - 14	20
	H - 9	30
140342001	Z1 - 16	68
140407001	C - 22	14
140418000	M - 5	46
	N - 5	48
140647001	P4 - 4-1-10	60
140759000	Z1 - 41	62
141183000	A - 103	2
141207001	C - 19	14
141208001	C - 23	14
141399001	Z1 - 47	68
141544001	C - 40-2-13	16
141598001	L - 66	44
	P2 - 66	54
141728001	C - 21	14
142027001	P3 - 1-25-2	58
142030000	P3 - 1-25-6-3	58
142274009	A - 49	2

CODE	REF.NO.	PAGE
142359001	G - 5	26
142721001	Z1 - 8	62
142998001	Z1 - 90-13	62
142999001	Z1 - 91-17	64
143311001	F - 23	24
143312000	F - 24	24
143325001	C - 5	14
143484000	P4- 4-1-8	60
143485001	P4- 4-1-9	60
143564001	E - 49	22
143565001	E - 51	22
143602001	K1 - 42	34
	K2 - 42	38
144053001	E - 1-9	20
144055001	E - 1-10	20
144075001	K1 - 114	36
	K2 - 114	40
144103009	K1 - 15	34
	K2 - 15	38
144104001	K1 - 18	34
	K2 - 18	38
144105000	K1 - 17	34
	K2 - 17	38
144110001	K1 - 19	34
	K2 - 19	38
144224001	Z1 - 42	62
144504001	K1 - 105	36
	K2 - 105	40
	K2 - 82	40
144505000	K1 - 106	36
	K2 - 106	40
	K2 - 83	40
144619000	G - 3-1	26
144622001	G - 3-5	26
144875001	G - 3-10	26
144876001	G - 3-11	26
145277105	Z1 - 20	62
145446001	K1 - 16	34
	K2 - 16	38
145472001	C - 24	14
145663001	E - 1-2	20
145688000	B - 20	10
145737001	G - 21	26
146049001	Z1 - 7	62
146080009	P4- 4-1-7	60
146315000	A - 125	4
146354001	P4- 2-4	60
	Z1 - 58-2	66
146360002	N - 71	50
	Z1 - 55	66
146401001	E - 1-4	20
146402001	E - 1-5	20
146403001	E - 1-6	20
146404001	E - 1-7	20
146427001	B - 30-1	12
	C - 40-2-6	16
	C - 40-3-6	16
	C - 40-5-6	18
	C - 40-6-6	18
	K2 - 86	40
146457001	A - 135	4
146528102	E - 1	20
146529001	E - 1-11	20
146530001	E - 1-13	20
146531001	E - 1-14	20
146532001	E - 2	20

CODE	REF.NO.	PAGE
146533001	E - 6	20
146538001	E - 13	20
146539000	E - 15	20
146540000	E - 16	20
146544000	E - 20-2	20
146547000	E - 41	20
	J - 17	32
146548101	E - 42	20
146554001	E - 25	20
146555001	E - 26	20
146556001	E - 53	22
146559001	E - 57	22
146560101	E - 58	22
146563001	E - 63	22
146586009	A - 110	2
	A - 129	4
	A - 50	6
146624101	H - 18	30
146740000	M - 25	46
	N - 31	48
146741000	E - 39	20
146924000	K1 - 96-1	36
	K2 - 96-1	40
147318000	E - 3	20
147363000	G - 48	26
147527001	G - 3-8	26
147528100	G - 3-13	26
147529001	G - 3-14	26
147691000	L - 40	42
	P2 - 40	54
147774001	P3 - 1-25-1	58
147776001	P3 - 1-25	58
147826001	P3 - 1-25-6-1	58
147835001	P3 - 1-25-6	58
147843001	N - 50	48
147846002	C - 20	14
147893009	Z1 - 22	62
147919001	Z1 - 35	62
148007001	L - 14	42
148042001	Z1 - 45	68
148084001	A - 30	2
148196000	J - 11	32
148197000	J - 12	32
148294001	L - 42	42
	P2 - 42	54
148372001	C - 4	14
148425001	H - 1-1	30
	H - 18-1	30
	K1 - 45-2	34
	K2 - 45-2	38
	L - 10-1	42
	M - 3-1	46
	N - 3-1	48
148431209	Z1 - 64-1	66
148432009	Z1 - 64-2	66
148834001	E - 54	22
	J - 15-3	32
	J - 18	32
	N - 86	50
148847001	A - 57	6
	H - 26	30
	J - 7	32
	L - 55	44
	L - 65	44
	P2 - 55	54
	P2 - 65	54
	Z1 - 69	68







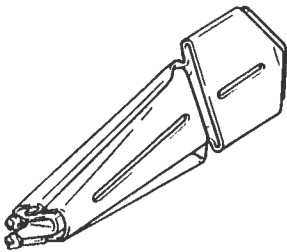
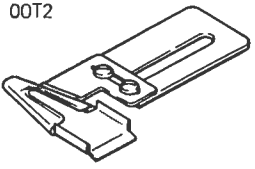
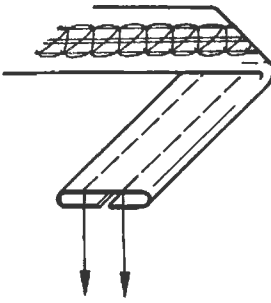
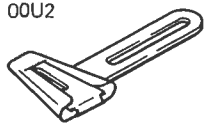



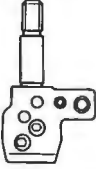

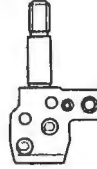
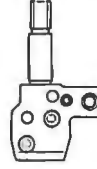
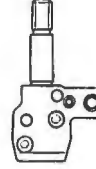





CODE	REF.NO.	PAGE
149173001	Z1 - 9	66
149247001	Z1 - 26	62
149547000	P1 - 25	52
	P2 - 86	54
149566009	K1 - 21-1	34
	K1 - 22-1	34
	K1 - 23-1	34
	K1 - 26-1	34
	K2 - 21-1	38
	K2 - 22-1	38
	K2 - 23-1	38
	K2 - 25-1	38
	K2 - 26-1	38
149604001	M - 24-1	46
150106003	Z1 - 67-1-3	68
	Z1 - 90-4	62
	Z1 - 91-4	64
150145009	Z1 - 67-1-4	68
	Z1 - 90-12	62
	Z1 - 91-16	64
150172003	Z1 - 67-1-2	68
	Z1 - 90-3	62
	Z1 - 91-3	64
150173003	Z1 - 67-1-3-1	68
	Z1 - 90-4-1	62
	Z1 - 91-4-1	64
150174000	Z1 - 67-1-7	68
	Z1 - 90-5	62
	Z1 - 91-5	64
150179002	Z1 - 90-7-1	62
	Z1 - 91-8-1	64
	Z1 - 91-9-1	64
150180001	Z1 - 90-8	62
	Z1 - 91-10	64
150182000	Z1 - 90-9	62
	Z1 - 91-11	64
150185009	Z1 - 67-1-4-1	68
	Z1 - 90-12-1	62
	Z1 - 91-16-1	64
150188009	Z1 - 91-13-1	64
150189009	Z1 - 67-1-1	68
	Z1 - 90-1	62
	Z1 - 91-1	64
150335001	Z1 - 10	62
150579009	Z1 - 67-1	68
150580001	Z1 - 67-1-5	68
150581001	Z1 - 67-1-6	68
150582001	Z1 - 67-1-6-1	68
150604101	L - 22-3	42
150605001	L - 22-4	42
150606001	L - 22-5	42
150631001	L - 58	44
	P2 - 58	54
150644009	K2 - 3	38
150645009	K1 - 4	34
	K2 - 4	38
150755001	M - 29	46
150778103	Z1 - 67	68
151059001	A - 137	4
151090001	L - 18	42
151429001	G - 9	26
151927001	G - 52	28
152567000	P3 - 1-1-14	56
153484001	E - 11	20
153675001	A - 44	2
	L - 33	42
	N - 63	50







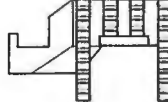

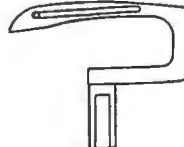

CODE	REF.NO.	PAGE
153675001	P2 - 33	54
153734001	F - 3	24
154596000	C - 27	14
154841009	A - 23	2
	A - 24	2
154886001	F - 6	24
154943001	D - 7	18
154945001	D - 7-2	18
154956001	C - 9	14
154957001	C - 11	14
154965001	E - 70	22
	K1 - 101	36
	K1 - 103	36
	K2 - 101	40
	K2 - 103	40
155103001	C - 40-3-13	16
155144001	E - 17	20
155145000	E - 18	20
155151000	E - 29	20
155162001	K1 - 56	34
	K2 - 56	38
155175001	E - 66	22
155176001	E - 67	22
155177100	E - 32	20
155178001	E - 33	20
155220000	C - 8	14
	K1 - 48	34
	K2 - 48	38
155282101	G - 29	26
155294100	G - 49	28
155295001	G - 50	28
155313001	K1 - 113	36
	K2 - 113	40
155510001	K1 - 107	36
	K2 - 107	40
	K2 - 84	40
155539000	B - 47	10
	C - 13	14
	H - 6	30
	K1 - 53	34
	K2 - 53	38
	M - 7	46
	N - 7	48
155697001	K1 - 26-2	34
	K2 - 26-2	38
155697002	K1 - 23-2	34
	K2 - 23-2	38
155697003	K1 - 21-2	34
	K2 - 21-2	38
	K2 - 25-2	38
155697004	K1 - 22-2	34
	K2 - 22-2	38
155914001	M - 19	46
156309001	Z1 - 12	68
156479009	P4 - 4-1-15-1	60
156887001	A - 29	2
156998001	P4 - 4-1-12	60
157840000	G - 15	26
159150009	A - 7	2
159476000	G - 25	26
159574101	K1 - 13	34
	K2 - 13	38
181969003	A - 104	2
181995001	G - 3-6	26
183161209	Z1 - 64	66
200190001	P3 - 1-26	58
	P4 - 3-3	60

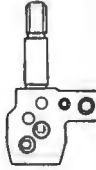
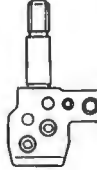
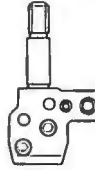

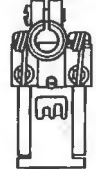
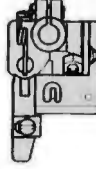

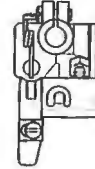
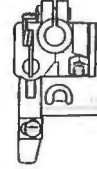
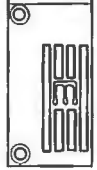

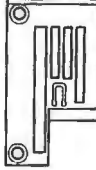
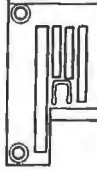
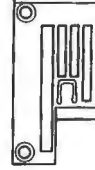
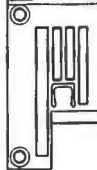
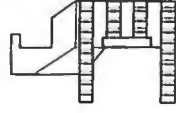
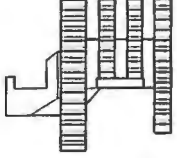
CODE	REF.NO.	PAGE
200190001	P4 - 4-8	60
211964001	Z1 - 31	62
502677001	P3 - 1-1-29	56
	P3 - 1-1-3	56
	P3 - 1-7-4	56
525907000	P3 - 1-22	58
533658001	P3 - 1-1-2	56
	P3 - 1-7-15	56
535808001	P3 - 1-3	56
554482000	P3 - 1-13	56
575456001	D - 2	18
S25099001	Z1- 29	62
S14621001	B - 2-1	10
S14622001	F - 1-2	24
S14623001	F - 11-2	24
S28821000	R - 1-1-2-5	46
021080302	R - 1-7	46

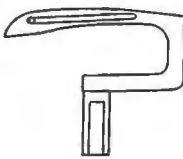

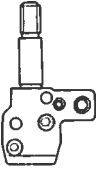



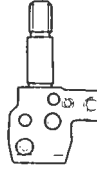
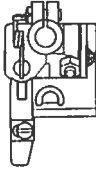
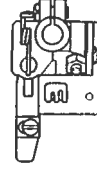
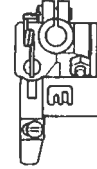
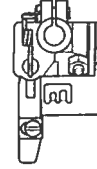
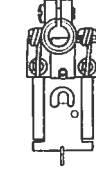
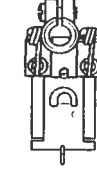
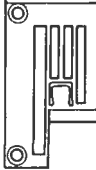
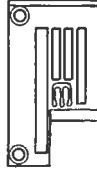
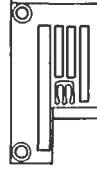
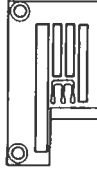

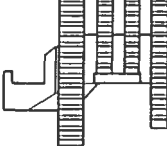
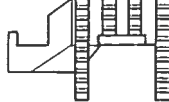
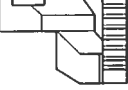
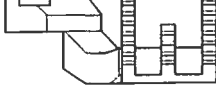
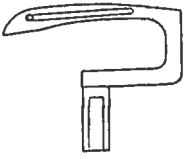
本式テープバインダ Binder for tape attachment in the Bed side type CB2710 0021 CB2720 0021	三ツ折 /Single Fold Binding			四ツ折 /Double Fold Binding			
	仕上り幅(mm) Finished Size (mm)	テープ幅(mm) Tape Size (mm)	部品コード Parts No.	仕上り幅(mm) Finished Size (mm)	テープ幅(mm) Tape Size (mm)	部品コード Parts No.	
	6	18	S09503-001	6	24	S09515-001	
	8	24	S09504-001	8	30	S09516-001	
	10	28	S09505-001	10	36	S09517-001	
	12	32	S09506-001	12	42	S09518-001	
	13	34	S09507-001	13	44	S09519-001	
	15	40	S09508-001	15	48	S09520-001	
	16	42	S09509-001	16	50	S09521-001	
	17	44	S09510-001	17	52	S09522-001	
	18	46	S09511-001	18	54	S09523-001	
	20	50	S09512-001	20	58	S09524-001	
	23	56	S09513-001	23	64	S09525-001	
	25	60	S09514-001	25	68	S09526-001	
	平置式テープバインダ Binder for tape attachment in the Bed on type CB2710 0011 CB2720 0011	6	18	S09527-001	6	24	S09539-001
		8	24	S09528-001	8	30	S09540-001
		10	28	S09529-001	10	36	S09541-001
12		32	S09530-001	12	42	S09542-001	
13		34	S09531-001	13	44	S09543-001	
15		40	S09532-001	15	48	S09544-001	
16		42	S09533-001	16	50	S09545-001	
17		44	S09534-001				
18		46	S09535-001	18	54	S09547-001	
20		50	S09536-001	20	58	S09548-001	
23		56	S09537-001	23	64	S09549-001	
25		60	S09538-001	25	68	S09550-001	
前メス無ベルトループホルダ Belt loop holder without front cutter CB2710 00T1 CB2710 00T2				8	16	S09551-001	
				9	18	S09552-001	
前メス有ベルトループホルダ Belt loop holder with front cutter CB2710 00U1 CB2710 00U2				10	20	S09553-001	
	12			24	S09554-001		
			15	30	S09555-001		
			20	40	S09556-001		
			8	16	S09557-000		
			9	18	S09558-000		
			10	20	S09559-000		
			12	24	S09560-000		
			15	30	S09561-000		
			20	40	S09562-000		





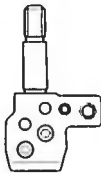
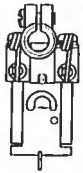
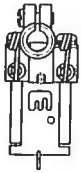
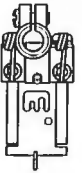
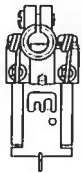
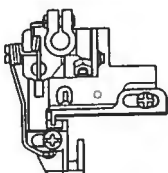
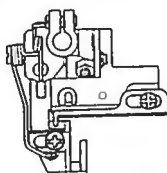
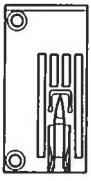

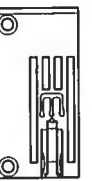

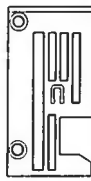
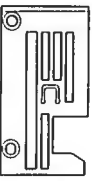
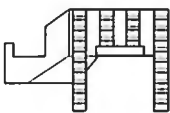
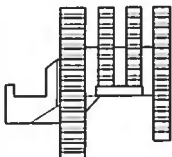
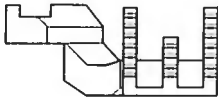
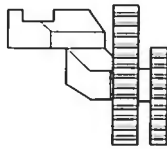
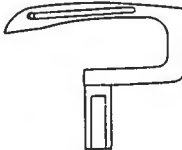

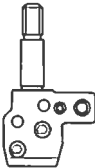
ゲージ部品一覧表/GAUGE PARTS LIST

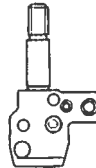

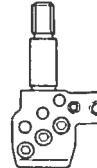
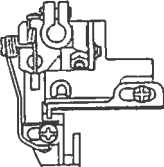
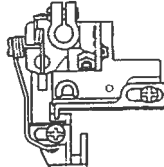
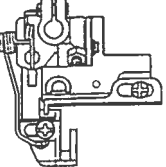
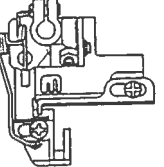
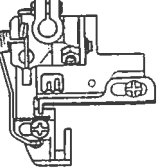
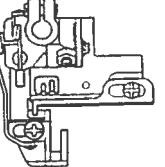

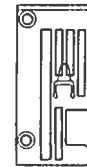
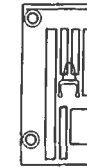

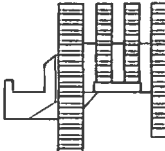
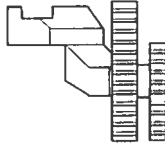
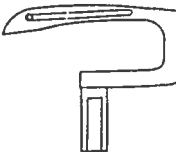

機種 Model	CB2710 CB2720	CB2710 CB2720	CB2710 CB2720	CB2710 CB2720	CB2710 CB2720	CB2710 CB2720
仕様 Specifications	0011-232	0011-240	0011-248	0011-256	0011-264	0011-348
仕様ラベル Label	S19854-001	S19854-002	S19854-003	S19854-004	S19854-005	S19854-006
用途 Application	地縫用 Plain Stitching					
針数(本) No. of Needles	2	2	2	2	2	3
針巾(mm) Needle Spacing (mm)	3.2	4.0	4.8	5.6	6.4	4.8
針止メ組 Needle Clamp Assembly	 S08699-001	 S08701-001	 S08703-001	 S08705-001	 S08707-001	 S08709-001
押工組 Presser Foot Assembly	 S08779-201	 S08786-201	 S08788-201	 S08790-201	 S08792-201	 S08794-201
針板 Needle Plate	 S08717-001	 S08718-001	 S08719-001	 S08720-001	 S08721-001	 S08722-001
主送り歯 Main Feed Dog	 S08882-001					
差動送り歯 Differential Feed Dog	 S08885-001					
ルーパー Looper	 S08913-001					



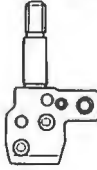
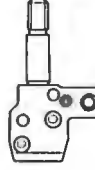

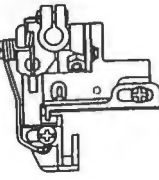
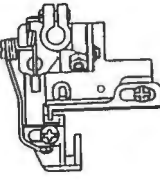
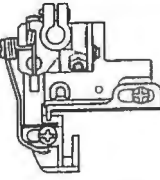
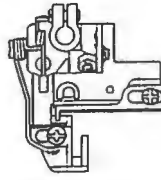
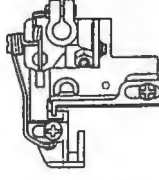
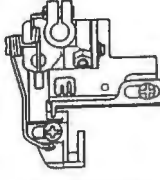
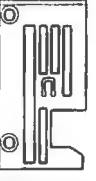
機 種 Model	CB2710 CB2720	CB2710 CB2720	CB2710 CB2720	CB2710 CB2720	CB2710 CB2720	CB2710 CB2720
仕 様 Specifications	0011 356	0011 364	0021 232	0021 240	0021 248	0021 256
仕様ラベル Label	S19854 007	S19854 008	S19854-009	S19854 010	S19854 011	S19854 012
用 途 Application	地 縫 用 Plain Stitching			テープ付用 Tape Stitching		
針 数(本) No. of Needles	3	3	2	2	2	2
針 巾(mm) Needle Spacing (mm)	5.6	6.4	3.2	4.0	4.8	5.6
針 止メ組 Needle Clamp Assembly	 S08711-001	 S08713 001	 S08699 001	 S08701-001	 S08703-001	 S08705 001
押 工 組 Presser Foot Assembly	 S08796-201	 S08798-201	 S08800-201	 S08813-201	 S08815-201	 S08818-201
針 板 Needle Plate	 S08723-001	 S08724 001	 S08725-101	 S08726-001	 S08727 001	 S08728 001
主 送 り 歯 Main Feed Dog	 S08882-001			 S08883-001		
差 動 送 り 歯 Differential Feed Dog	 S08885-001			 S08886 001		
ル ー パ Looper	 S08913-001					

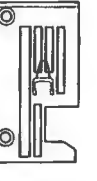
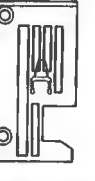

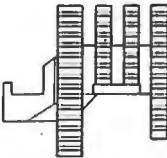
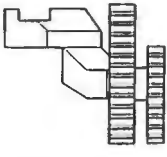
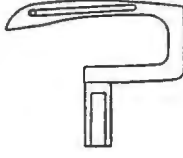



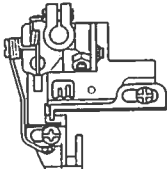
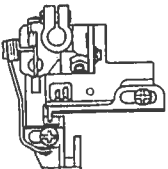

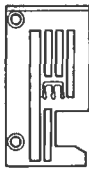
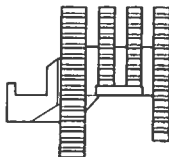
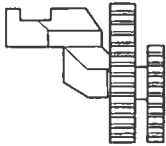
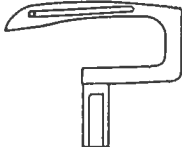
機種 Model	CB2710 CB2720	CB2710 CB2720	CB2710 CB2720	CB2710 CB2720	CB2710 CB2720	CB2710 CB2720
仕様 Specifications	0021-264	0021-348	0021-356	0021-364	0031-248	0031 256
仕様ラベル Label	S19854-013	S19854-014	S19854-015	S19854-016	S19854-017	S19854 018
用途 Application	テープ付用 Tape Stitching				カバーリング用 Covering	
針数(本) No. of Needles	2	3	3	3	2	2
針巾(mm) Needle Spacing (mm)	6.4	4.8	5.6	6.4	4.8	5.6
針止メ組 Needle Clamp Assembly	 S08707-001	 S08709-001	 S08711-001	 S08713-001	 S08703-001	 S08705 001
押工組 Presser Foot Assembly	 S08820-201	 S08822-201	 S08824-201	 S08826-201	 S08828-201	 S08830-201
針板 Needle Plate	 S08729-001	 S08730-001	 S08731-001	 S08732 001	 S08733-001	 S08734-001
主送り歯 Main Feed Dog	 S08883-001				 S08882-001	
差動送り歯 Differential Feed Dog	 S08886-001				 S08887-001	
ルーパー Looper	 S08913-001					

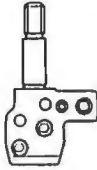
機種 Model	CB2710 CB2720	CB2710 CB2720	CB2710 CB2720	CB2710 CB2720	CB2710 CB2720	CB2710 CB2720
仕様 Specifications	0031-264	0031-348	0031-356	0031-364	0071-232	0071-240
仕様ラベル Label	S19854-019	S19854-020	S19854-021	S19854-022	S19854-023	S19854-024
用途 Application	カバーリング用 Covering				レースゴム付用 (上ゴム送り装置付) (トリミングメス装置付) Elastic Lace Attaching (w/Top Metering Device & Edge trimming device)	
針数(本) No. of Needles	2	3	3	3	2	2
針巾(mm) Needle Spacing (mm)	6.4	4.8	5.6	6.4	3.2	4.0
針止メ組 Needle Clamp Assembly	 S08707-001	 S08709-001	 S08711-001	 S08713-001	 S08699-001	 S08701-001
押工組 Presser Foot Assembly	 S08832-201	 S08834-201	 S08836-201	 S08838-201	 S08840-201	 S08848-201
針板 Needle Plate	 S08735-001	 S08736-001	 S08737-001	 S08738-001	 S08739-001	 S08740-001
主送り歯 Main Feed Dog	 S08882-001				 S08883-001	
差動送り歯 Differential Feed Dog	 S08887-001				 S08888-101	
ルーパー Looper	 S08913-001					

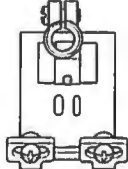
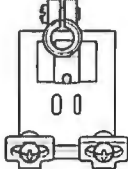
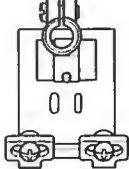
機種 Model	CB2710 CB2720	CB2710 CB2720	CB2710 CB2720	CB2710 CB2720	CB2710 CB2720	CB2710 CB2720
仕様 Specifications	0071-248	0071-256	0071-264	0071-348	0071-356	0071-364
仕様ラベル Label	S19854-025	S19854-026	S19854-027	S19854-028	S19854-029	S19854-030
用途 Application	レースゴム付用 (上ゴム送り装置付) トリミングメス装置付 Elastic Lace Attaching (w/Top Metering Device & Edge Trimming Device)					
針数(本) No. of Needles	2	2	2	3	3	3
針巾(mm) Needle Spacing (mm)	4.8	5.6	6.4	4.8	5.6	6.4
針止メ組 Needle Clamp Assembly	 S08703-001	 S08705-001	 S08707-001	 S08709-001	 S08711-001	 S08713-001
押工組 Presser Foot Assembly	 S08850-201	 S08852-201	 S08854-201	 S08856-201	 S08858-201	 S08860-201
針板 Needle Plate	 S08741-001	 S08742-001	 S08743-001	 S08744-001	 S08745-001	 S08746-001
主送り歯 Main Feed Dog	 S08883-001					
差動送り歯 Differential Feed Dog	 S08888-001					
ルーパー Looper	 S08913-001					

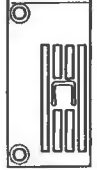
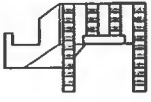
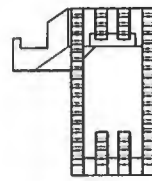
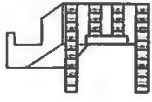
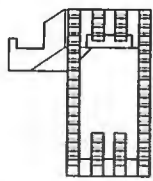
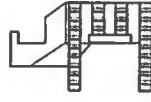
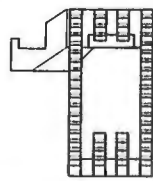



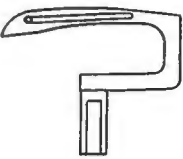

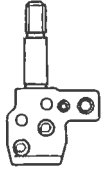
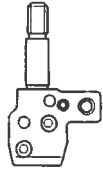
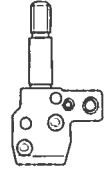
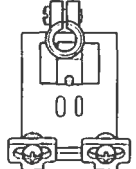
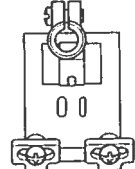
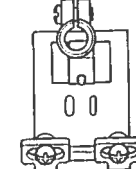
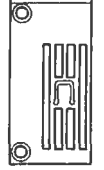
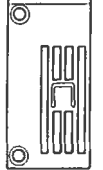
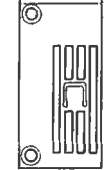
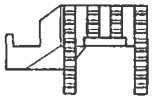
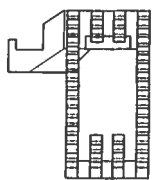
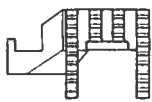
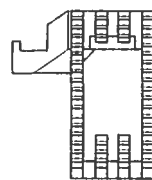
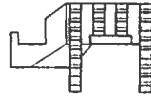
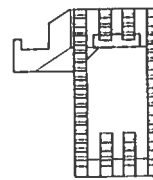
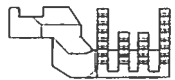
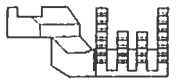
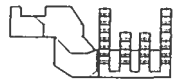
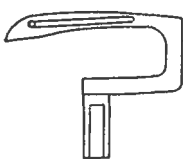

機種 Model	CB2710 CB2720	CB2710 CB2720	CB2710 CB2720	CB2710 CB2720	CB2710 CB2720	CB2710 CB2720
仕様 Specifications	007□-232 (□は1を除く) 007□ - except 1	007□-240 (□は1を除く) 007□ - except 1	007□-248 (□は1を除く) 007□ - except 1	007□-256 (□は1を除く) 007□ - except 1	007□-264 (□は1を除く) 007□ - except 1	007□-348 (□は1を除く) 007□ - except 1
仕様ラベル Label	S19854-048	S19854-049	S19854-050	S19854-051	S19854-052	S19854-053
用途 Application	レースゴム付用 (P.M.ゴム送り装置付) トリミングメス装置付 Elastic Lace Attaching (Pulse Motor Drive Top Metering Device & Edge trimming device)					
針数(本) No. of Needles	2	2	2	2	2	3
針巾(mm) Needle Spacing (mm)	3.2	4.0	4.8	5.6	6.4	4.8
針止メ組 Needle Clamp Assembly	 S08699-001	 S08701-001	 S08703-001	 S08705-001	 S08707-001	 S08709-001
押工組 Presser Foot Assembly	 S08840-201	 S08848-201	 S08850-201	 S08852-201	 S08854-201	 S08856-201
針板 Needle Plate	 S08739-001	 S08740-001	 S08741-001	 S08742-001	 S08743-001	 S08744-001
主送り歯 Main Feed Dog	 S08883-001					
差動送り歯 Differential Feed Dog	 S08888-101					
ルーパー Looper	 S08913-001					

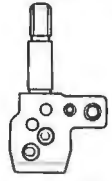
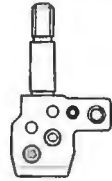
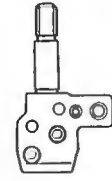

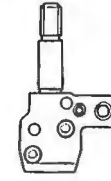

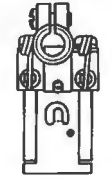
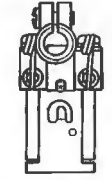
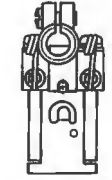
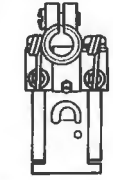
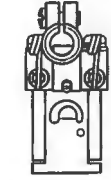
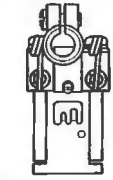
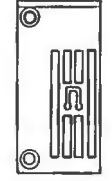

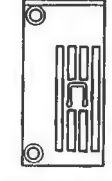
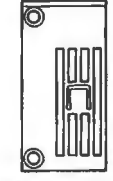
機種 Model	CB2710 CB2720	CB2710 CB2720				
仕様 Specifications	007□-356 (□は1を除く) 007□-except 1	007 364 □は1を除く 007 ex-cept □				
仕様ラベル Label	S19854-054	S19854-055				
用途 Application	レースゴム付用 (P.M.ゴム送り装置付) トリミングメス装置付 Elastic Lace Attaching (Pulse Motor Drive Top Metering Device & Edge trimming device)					
針数(本) No. of Needles	3	3				
針巾(mm) Needle Spacing (mm)	5.6	6.4				
針止め組 Needle Clamp Assembly	 S08711-001	 S08713-001				
押し組 Presser Foot Assembly	 S08858-201	 S08860-201				
針板 Needle Plate	 S08745-001	 S08746-001				
主送り歯 Main Feed Dog	 S08883-001					
差動送り歯 Differential Feed Dog	 S08888-101					
ルーパー Looper	 S08913-001					

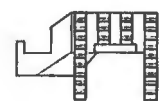
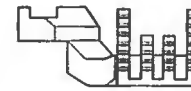
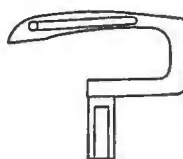
機種 Model	CB2710	CB2710	CB2710	CB2710	CB2710	CB2710
仕様 Specifications	00T1 248	00U1-248	00T1 256	00U1-256	00T1 264	00U1 264
仕様ラベル Label	S19854 031	S19854-037	S19854 032	S19854 038	S19854 033	S19854-039
用途 Application	ヘルトループ縫用 薄物・中厚物 Belt Loop Sewing Thin · Medium	ベルトループ縫用 薄物・中厚物 (前メス装置付) Belt Loop Sewing Thin · Medium (w/Front Cutter)	ベルトループ縫用 薄物・中厚物 Belt Loop Sewing Thin · Medium	ヘルトループ縫用 薄物・中厚物 (前メス装置付) Belt Loop Sewing Thin · Medium (w/Front Cutter)	ヘルトループ縫用 薄物・中厚物 Belt Loop Sewing Thin · Medium	ヘルトループ縫用 薄物・中厚物 (前メス装置付) Belt Loop Sewing Thin · Medium (w/Front Cutter)
針数(本) No. of Needles	2		2		2	
針巾(mm) Needle Spacing (mm)	4.8		5.6		6.4	
針止メ組 Needle Clamp Assembly	 S08703-001	 S08705-001	 S08707-001			
押し組 Presser Foot Assembly	 S08862-101	 S08866-101	 S08868-101			
針板 Needle Plate	 S08719-001	 S08720-001	 S08721-001			
主送り歯 Main Feed Dog	 S08882-001	 S08884-001	 S08882-001	 S08884-001	 S08882-001	 S08884-001
差動送り歯 Differential Feed Dog	 S08885-001		 S08885-001		 S08885-001	
ルーパー Looper	 S08913-001					

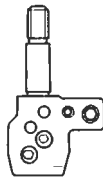
機種仕様 Model Specifications 仕様ラベル Label	CB2710	CB2710	CB2710	CB2710	CB2710	CB2710
	00T2-248	00U2-248	00T2-256	00U2-256	00T2-264	00U2 264
	S19854-034	S19854-040	S19854-035	S19854-041	S19854-036	S19854 042
用途 Application	ベルトループ縫用 厚物用 Belt Loop Sewing Thick	ベルトループ縫用 厚物用 (前メス装置付) Belt Loop Sewing Thick (w/Front Cutter)	ベルトループ縫用 厚物用 Belt Loop Sewing Thick	ベルトループ縫用 厚物用 (前メス装置付) Belt Loop Sewing Thick (w/Front Cutter)	ベルトループ縫用 厚物用 Belt Loop Sewing Thick	ベルトループ縫用 厚物用 (前メス装置付) Belt Loop Sewing Thick (w/Front Cutter)
針数(本) No. of Needles	2		2		2	
針巾(mm) Needle Spacing (mm)	4.8		5.6		6.4	
針止メ組 Needle Clamp Assembly	 S08703-001		 S08705-001		 S08707-001	
押工組 Presser Foot Assembly	 S08862-101		 S08866-101		 S08868-101	
針板 Needle Plate	 S08747-001		 S08748-001		 S08749-001	
主送り歯 Main Feed Dog	 S08882-001	 S08884-001	 S08882-001	 S08884-001	 S08882-001	 S08884 001
差動送り歯 Differential Feed Dog	 S08885-001		 S08885-001		 S08885-001	
ルーパー Looper	 S08913-001					

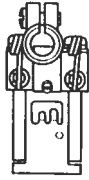
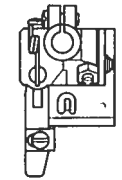
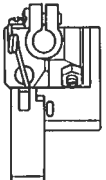
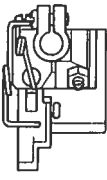
ゲージ部品一覧表 (オプション) / GAUGE PARTS LIST (OPTION)

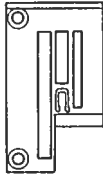
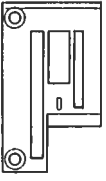
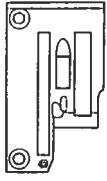
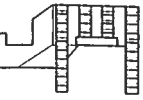
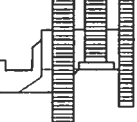
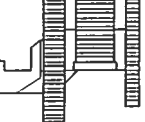
機種 Model	CB2710 CB2720	CB2710 CB2720	CB2710 CB2720	CB2710 CB2720	CB2710 CB2720	CB2710 CB2720
仕様 Specifications	for 0011-232	for 0011-240	for 0011-248	for 0011-256	for 0011-264	for 0011-356
仕様ラベル Label	Option	Option	Option	Option	Option	Option
用途 Application	地縫用(厚物用) Plain Stitching (Heavy)					
針数(本) No. of Needles	2	2	2	2	2	3
針巾(mm) Needle Spacing (mm)	3.2	4.0	4.8	5.6	6.4	5.6
針止メ組 Needle Clamp Assembly	 S08699-001	 S08701-001	 S08703-001	 S08705-001	 S08707-001	 S08711-001
押工組 Presser Foot Assembly	 S08779-201	 S08786-201	 S08788-201	 S08790-201	 S08792-201	 S08796-201
針板 Needle Plate	 S14074-001	 S14075-001	 S08747-001	 S08 48-001	 S08749-001	 S14077-001
主送り歯 Main Feed Dog	 S08882-001					
差動送り歯 Differential Feed Dog	 S08885-001					
ルーパー Looper	 S12683-001					

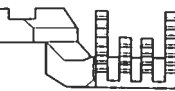
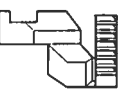
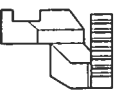
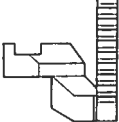
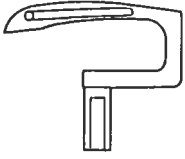
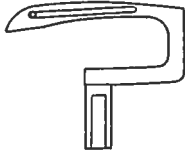
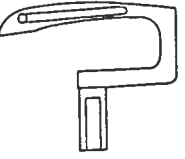
機種 Model	CB2710 CB2720	CB2710 CB2720	CB2720	CB2720		
仕様 Specifications	for 0011-364	for 0021-232	for 0025-100	for 0026-100		
仕様ラベル Label	Option	Option	S19854-046	S19854-047		
用途 Application	地縫用(厚物用) Plain Stitching (Heavy)	テープ付用 Tape Stitching		リンキング用 Linking		
針数(本) No. of Needles	3	2	1	1		
針巾(mm) Needle Spacing (mm)	6.4	3.2	-	-		
針止メ組 Needle Clamp Assembly	 S08713-001	 S08699-001	 S17480-001			
押し組 Presser Foot Assembly	 S08798-201	 S08800-201	 S17484-001	 S17489-001		
針板 Needle Plate	 S14078-001	 S18047-001	 S17482-001	 S17483-001		
主送り歯 Main Feed Dog	 S08882-001	 S18049-001	 S17494-001	 S17495-001		
差動送り歯 Differential Feed Dog	 S08885-001	 S18050-001	 S08886-001	 S17496-001		
ルーパー Looper	 S12683-001	 S08913-001		 S12683-001		

brother®

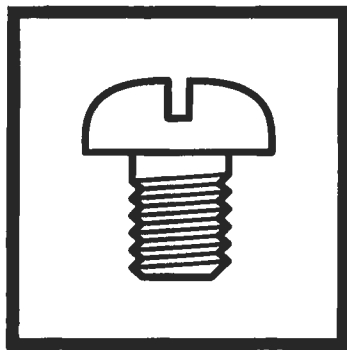

パーツブック
PARTS BOOK

ブラザー工業株式会社

〒467-8561 名古屋市瑞穂区苗代町15番1号 TEL(052)824-2392

BROTHER INDUSTRIES, LTD.

15-1, Naeshiro-cho, Mizuho-ku, Nagoya 467-8561, Japan. Phone: 81-52-824-2177

Printed in Japan

118-271
195271-501
2002.04. B (1)

From the library of: Superior Sewing Machine & Supply LLC